

Butcher Boy

FROZEN MEAT FLAKER

AU-MF

**FLAKES (Doesn't Chip) FROZEN
MEAT BLOCKS IN
8 TO 12 SECONDS.**

Full sized blocks, properly
tempered, up to 9" thick, 22"
wide and 24" long. Requires little
floor space.

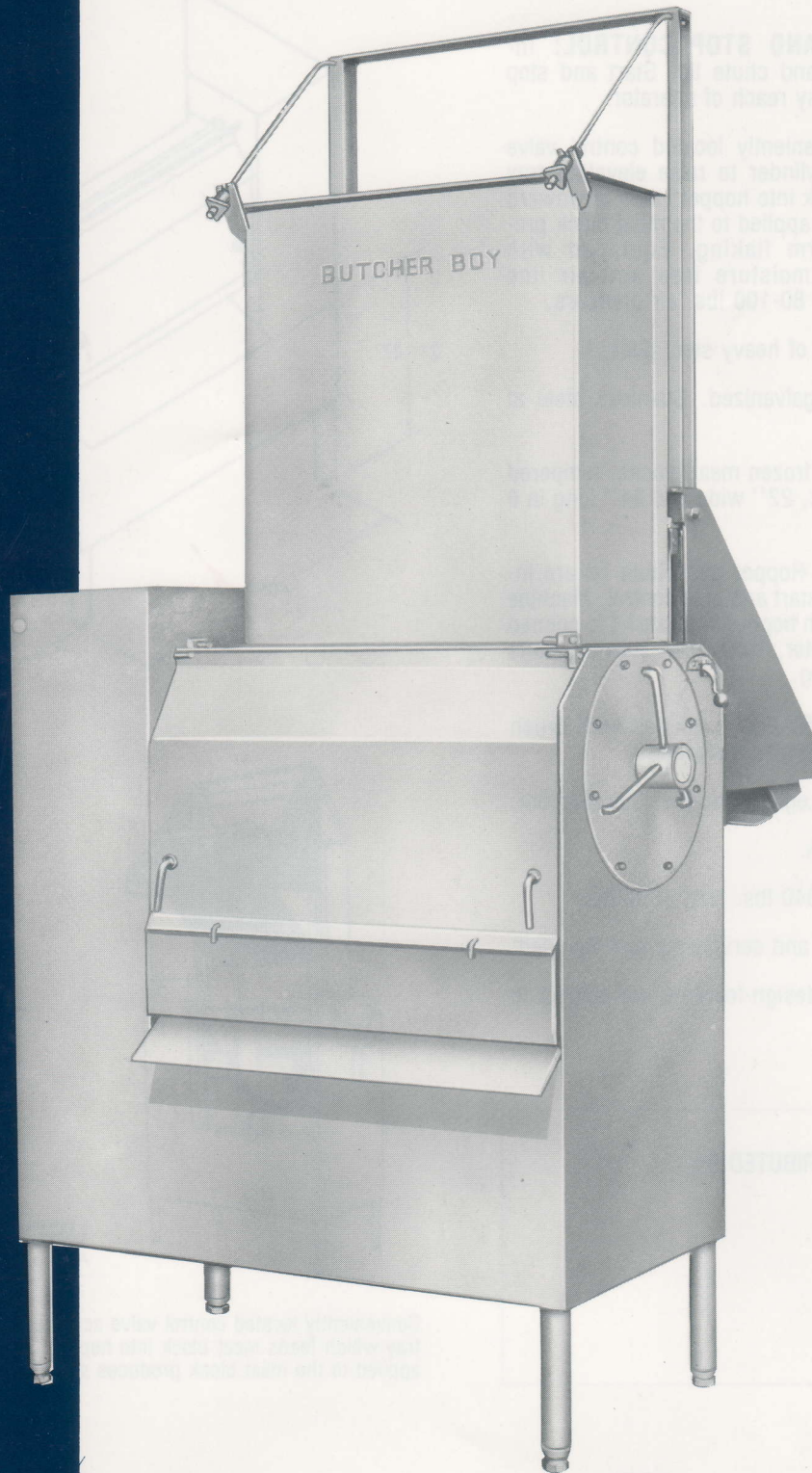

17401
Los Angeles
Phone (213) 50

Butcher Boy USA

SPECIFICATIONS

MOTOR: Heavy duty, 10 HP, 208, 230/460 volts, three phase, 60 cycles, open drip proof, standard. Motors conform to NEMA specifications. Single phase and other motors at variance with standard may be had on special order. Motor enclosed in housing.

MAGNETIC SWITCH: Standard equipment. Overload protection and automatic reset. Enclosed in housing.

ELECTRIC START AND STOP CONTROL: Interlocks with hopper and chute lid. Start and stop control lever within easy reach of operator.

AIR-CONTROL: Conveniently located control valve activates pneumatic cylinder to raise elevating tray which feeds meat block into hopper; then downward pressure automatically applied to the meat block produces speedy uniform flaking. Equipped with pressure regulator, moisture trap and air line lubricator; operates on 80-100 lbs. air pressure.

HOUSING: Fabricated of heavy steel plate.

FINISH: Hot dipped galvanized. Stainless steel at extra charge.

CAPACITY: Will flake frozen meat blocks, tempered properly up to 9" thick, 22" wide and 24" long in 8 to 12 seconds.

SAFETY FEATURES: Hopper and chute lid are interlocked with electric start and stop control. Machine will stop operating when hopper or chute lid is opened for cleaning, etc. Motor, drive and moving parts enclosed within housing.

SANITARY FEATURES: Easily cleaned with brush and hot water or can be steam cleaned.

VARIABLE HEIGHT: Legs adjustable. See diagram.

APPROVALS: U.S.D.A.

WEIGHT: Shipping: 1040 lbs. Net: 1000 lbs.

ACCESSORIES: Parts and service manual included.

NOTE: Specifications-design-features are subject to change without notice.

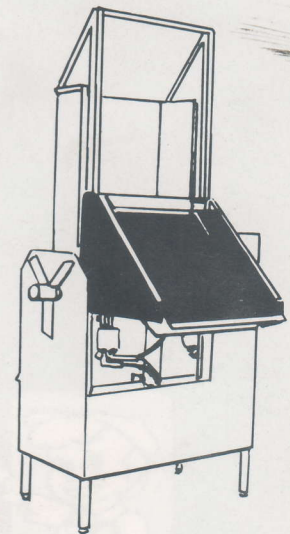
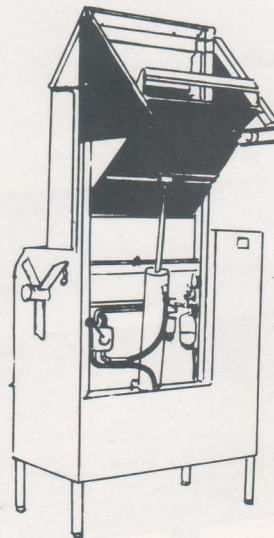
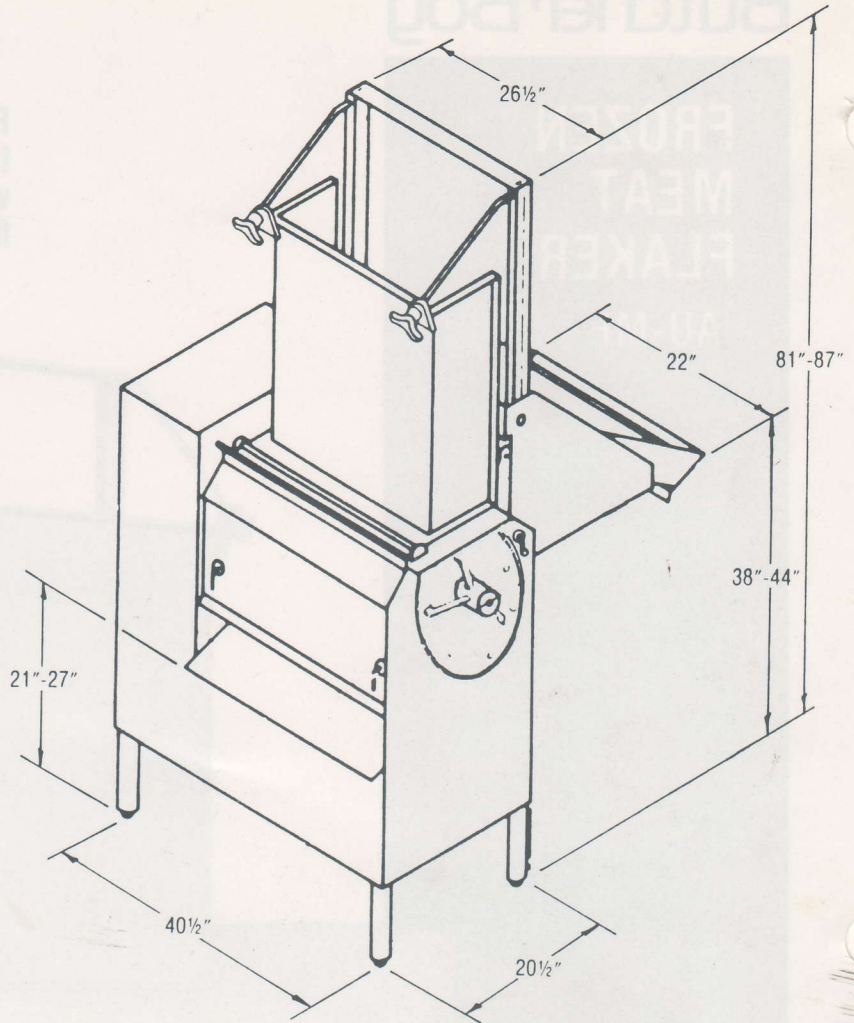

USDA
Accepted

Conveniently located control valve activates pneumatic cylinder to raise elevating tray which feeds meat block into hopper. Downward pressure automatically applied to the meat block produces speedy uniform flaking.

DISTRIBUTED BY:

Butcher Boy USA

11401 South Alameda Street
Los Angeles, California 90059
Phone (213) 564-3865 • FAX (213) 564-2401