

Lift Loaders & Dumpers

2



Model
LL-96

Signature Column Lift

Self contained, lifts and dumps automatically
Standard and custom dump heights

The Bridge Signature LL-96 lift is a purposeful, high quality lift that displays cleanliness and quality, and will surely compliment your facility and equipment. This lift is designed with standard features that are not available with most other brands. The Bridge Signature Lift is available up to 144" column height that allows for up to a 120" dump height.

Standard features:

- USDA accepted
- Stainless steel T-304 construction
- Polished 10-gauge stainless steel shell
- Polished 3 inch stainless steel tube post
- Stainless steel carriage with bronze bushings
- Stainless steel dump cradle with safety latch
- Stainless steel hinges
- 1.5 hp brake motor
- CRS: Carriage Retention Safety Catch
- Secondary top sensor for overall shutdown

Available options:

- Portable stand with stainless steel casters
- Chute extension for dump cradle
- Attachment brackets for most common forming equipment

Custom carriages for all container types:

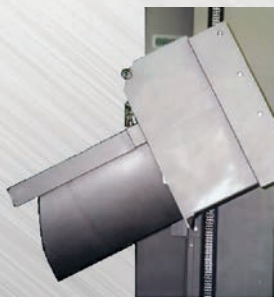

Carriage with chute



Drum carriage



Barrel carriage



Tote carriage

Workhorse Column Lift

400 lb to 1500 lb capacity
Standard and custom dump heights

Standard features:

- USDA accepted
- Stainless steel T-304 construction
- Floor level loading
- Quick adjust discharge height
- All stainless steel exterior
- 3/16" Heavy duty column
- Complete with electrical controls
- Positive chain lift with safety brake
- Variable discharge angle up to 45°
- 2, 3, 5 HP with electric brake
- Easy access to all components

Heavy Duty 1500 lb portable unit shown

Available options:

- Portable dolly
- Hinged access door with latch
- Stainless steel lift assembly
- Stainless steel guide post
- Waterproof chain
- Splash curtain
- Extra (safety) proximity switch at dump end of cycle

Accessories:

- Chutes
- Portable dolly
- Safety cages

Custom carriages for all container types:



Bowl carriage



Barrel carriage



Dumper with safety cage



400 lb portable

Lift Loaders & Dumpers

4

Tilt Dumpers

3,000 lb capacity

Larger capacities available

Unit shown with optional:

- Automatic adjustable hold down bar
- Air operated vat seals
- 3/8" Thick solid bottom
- Stainless steel electrical enclosure
- Dirt barrier
- Tapered liner

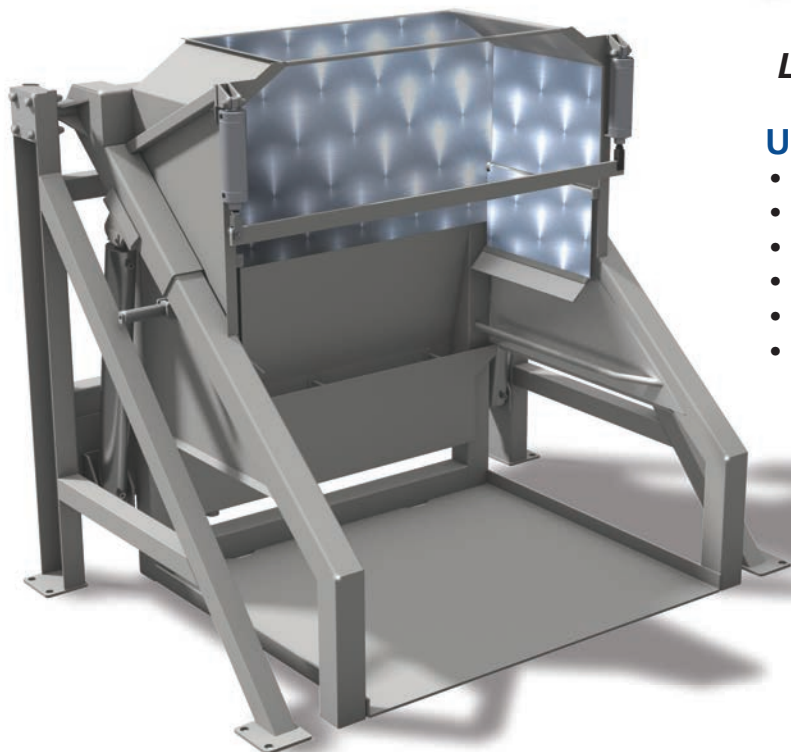

Power pack features:

- 5HP power pack
- Fixed volume gear pump
- Powered up and gravity down operation
- Single solenoid valve
- Pressure gauge/filter/etc.
- Mounted on an integrated 10 gallon stainless steel reservoir
- NEMA 4 electrical components are mounted in a fiberglass enclosure
- Up/down controls and motor starter



Portable
Tilt Dumper shown

Custom Dump Heights 36" to 84" are available

For taller dump heights, please see Hi-Lift Dumper section (page 6)

Lift Loaders & Dumpers



Shown with optional metering hopper and slide gate

Standard features:

- USDA accepted
- Stainless steel T-304 construction
- 1/4" Thick channel main uprights
- 10 gauge square tube frame
- 10 gauge liner
- Continuous 2-1/2 diameter pivot shaft
- Non-adjustable hold down bar
- (2) 3-1/2" Bore hydraulic lift cylinders
- 3/8" Thick mounting pads
- 3/8" Thick bottom runners
- Maintenance free UHMW bearings
- 1/4" and 3/8" thick bracing at stress points
- Glass bead blasted finish

Available options:

- Powered up and down
- Manual adjustable hold down bar
- Automatic adjustable hold down bar
- 3/8" solid bottom
- Vat seals
- Pickle tank
- Liner to base
- Folding V-Mag arms
- Free standing power pack
- Breakaway bottom
- Dirt barrier
- Stainless steel hydraulic cylinders
- Stainless steel electrical enclosure
- Side load feature
- Safety cage
- Tilt and extend chute
- Tapered liner
- Slide gate

Lift Loaders & Dumpers

6

Shown with optional breakaway bottom to guard against pallet contamination



Hi-Lift Dumpers

Standard features:

- USDA accepted
- Stainless steel T-304 construction
- 1/4" Thick channel main beams
- 10-Gauge square and rectangular tube frame
- 10-Gauge liner
- Continuous pivot shaft
- Non-adjustable hold down bar
- (2) 2-1/2" Bore-hydraulic lift cylinders
- (2) 3-1/2" Bore-hydraulic tilt cylinders
- 1/2" Thick mounting pads
- 3/8" Thick bottom runners
- Maintenance free UHMW bearings
- 1/4" and 3/8" Thick bracing at all stress points
- Cylinders have pilot operated check valves for safety
- Glass bead blasted finish
- 7.5 HP power pack

Available options:

- Manual adjustable hold down bar
- Automatic adjustable hold down bar
- 3/8" solid bottom
- Vat seals
- Pickle tank
- Liner to base
- Folding V-Mag arms
- Free standing power pack
- Breakaway bottom
- Dirt barrier
- Stainless steel hydraulic cylinders
- Stainless steel electrical enclosure
- Side load feature
- Safety cage
- Tilt and extend chute
- Tapered liner
- Slide gate
- Stainless steel fail-safe stops



Twin Column Dumpers

1,500 lb to 5,000 lb capacity
Custom built to your specific dump height

Shown with
optional safety
cage



Standard features:

- USDA accepted
- Stainless steel T-304 construction
- Electric motor
- 1/4" or 3/8" thick channel main beams
- Designed to fit your containers
- Maintenance free UHMW bearings
- Power up and down operation
- NEMA 4 electrical components mounted in fiberglass enclosure

Available options:

- Bolt together
- Split shaft
- Liner to base
- Tapered discharger liner
- Manual adjustable hold down bar
- Automatic adjustable hold down bar
- Vat seals
- Pickle tank
- Folding V-Mag arms
- Dirt barrier
- Stainless steel electrical enclosure
- Stainless steel motor cover with louvers
- Special outrigger frame
- Side load feature
- Safety stops for maintenance
- Stainless steel discs for brakes



Vat & V-Mag Inverters



Inverted view shown

Standard features:

- USDA accepted
- Stainless steel T-304 construction
- UHMW bearings
- Vat clamping system
- Outriggers for stability
- Ergonomic design
- All pneumatic controls
- All surfaces accessible for ease of cleaning containers
- Custom built to accommodate your container size
- Stainless steel enclosure
- Stainless steel cylinders

BackSaver

Standard features:

- USDA accepted
- Stainless steel T-304 construction
- Hydraulic with integrated power pack
- Custom built to accommodate your container
- Ergonomically designed so the product is more accessible to the operator

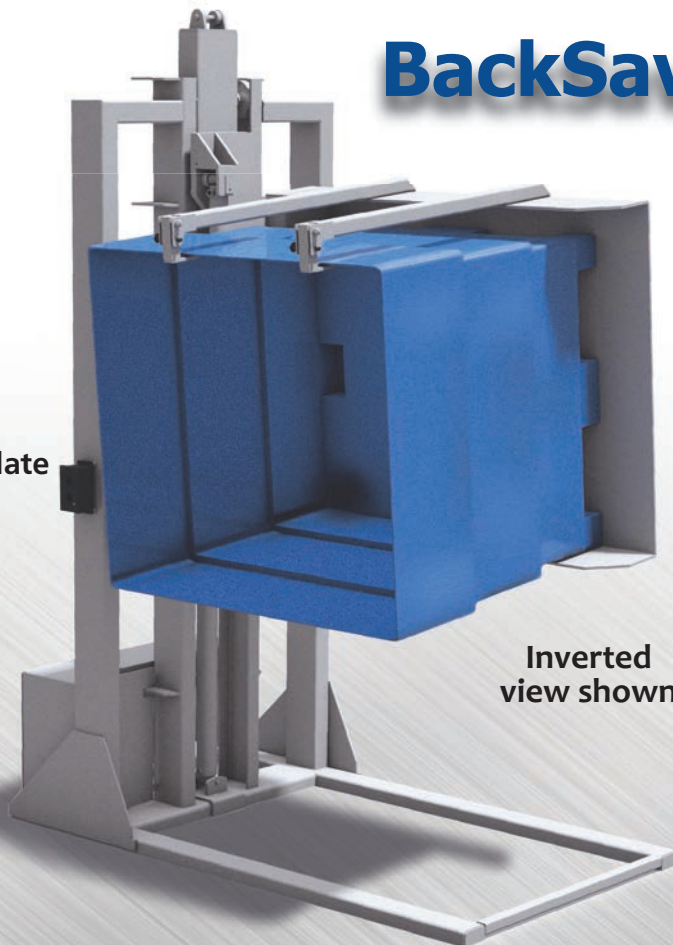

Inverted view shown