



VIBRATORY NET WEIGH SCALE

TE10 SERIES

Magnum Systems TE10 Series is an electronic, small net weigh scale designed for weighments of 2 oz to 12 lb. The TE10 series is designed with a solid mount net weigh bucket to increase accuracy. The TE10 Series will meter out granular material into bags, pouches or pails.

VARIABLE SPEED ELECTRONIC SCALE FOR PACKAGING SMALL ACCURATE WEIGHTS

Features

- Simplex, Duplex and Jumbo configurations
- Vibratory feeder
- Direct mount net-weigh bucket for increased fill speed
- Bulk and dribble fill cycle
- Adjustable product flow via rubber hopper transition
- Interchangeable spout for various containers
- T4000 weigh controller for precise filling

Optional Features

- Dual set point
- Adjustable flow boot
- Bulk accumulation for weights of 12 lbs
- Tool-less disassembly for clean-up
- Auto-zero

Materials Typically Handled

- Granulars
- Pet Food
- Salt
- Candies
- Seeds
- Grains



Engineering, Design & Manufacturing
to Keep the Line Moving

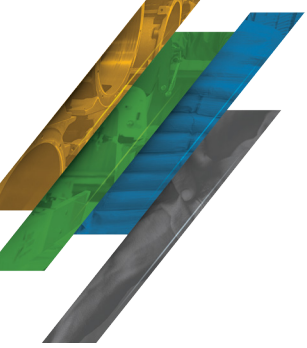

VIBRATORY NET WEIGH SCALE

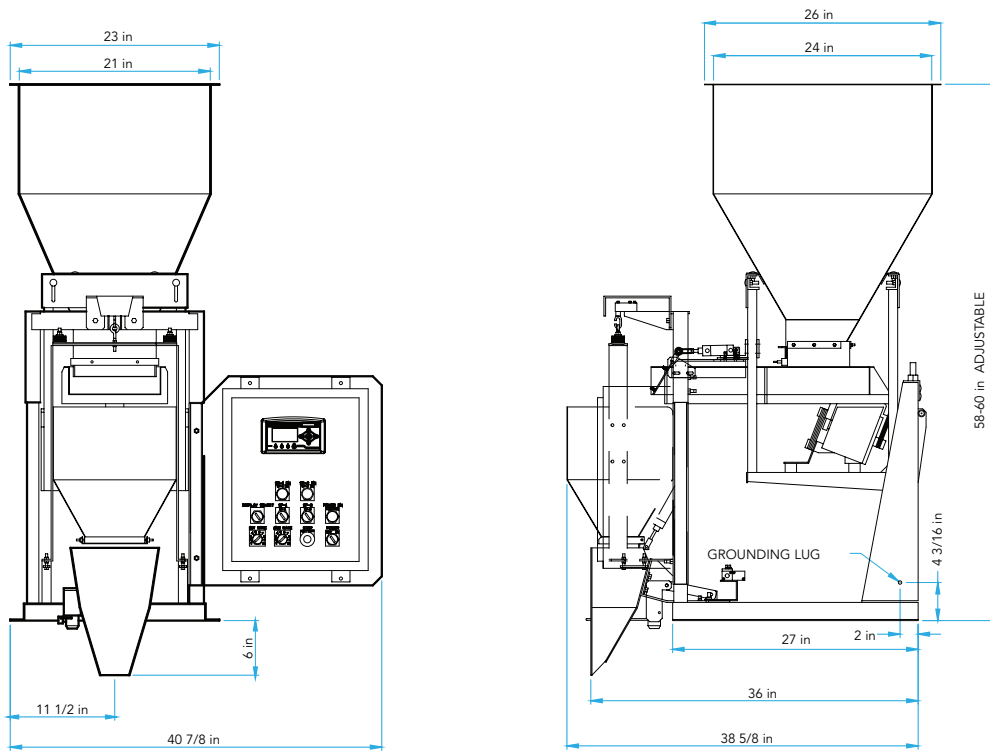

Diagram dimensions are for reference only*

SPECIFICATIONS

Speed	Up to 12 on Simplex, Up to 24 on Duplex weighments per minute
Accuracy	Up to 0.4%
Bag Weight Range	2 oz to 12 lb (0.057 kg to 5.443 kg) (Up to 25 lbs on Jumbo)
<i>Weight range is dependent on product's bulk density. Free product testing recommended.</i>	
Construction	Carbon steel blasted and painted
Electrical Requirements	120 Volt, 5 amp
Air Requirements	90 PSI, 1 cfm
Enclosures	NEMA12

TE10 - JUMBO DUPLEX



VIBRATORY TRAY

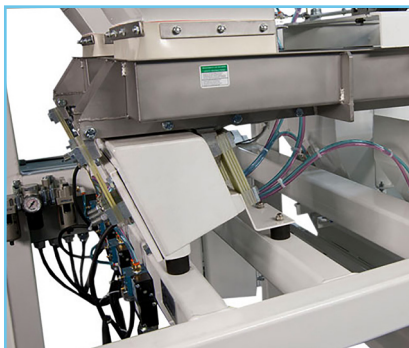

©2017 Magnum Systems, Inc. All rights reserved. Catalog number MS.1059.0917