

SPECIFICATIONS AND FEATURES

STANDARD MACHINE PRODUCTION

- Variable mold plate drive 30-65 strokes per minute
- Compression system 10 HP hydraulic
- Product pressure control—dial settings 25 PSI thru 200 PSI
- Hopper—positive feeding, 500 lbs. capacity
- Usable mold plate area—13" wide x 6" front to back
- Mold plate thickness 1/8" thru 1"
- Centralized lubrication system
- Bottom plate cranks down for easy mold plate change
- One standard mold plate and knock-out cup assembly included with machine

ELECTRICAL AND SAFETY

- 15/20 KVA rating
- 240—380—420—460 volts, 50/60 HZ, 3 phase, 60/40 AMPS
- Push button panel with circuit breaker, NEMA 4 Standard
- Radiant type heater for knock-out cups with adjustable temperature control
- Safety guards with electrical interlocks
- Easy access emergency "Off" push button
- Push button for jogging mold plate

SANITATION

- Gasket sealed stainless steel machinery cabinet with recirculating blower
- Pack-off conveyor belt releases for clean-up
- Paper hopper, vacuum bar and vacuum cups removable for cleaning
- USDA Animal and Plant Health Inspection Service approved

PAPER FEED SYSTEM PRODUCTION

- Papers patties at 30-65 strokes per minute
- Paper hopper, vacuum bar and vacuum cups are easily interchanged when changing paper size
- Standard paper sizes:
4 1/4", 4 1/2", 4 3/4", 5", 5 1/2", 5 3/4", 6"
- Electronic counter, 1-31 patties per stack
- Maximum stack height 5 1/2"

OPERATOR'S PANEL—NEMA 4 STANDARD



INSTALLATION DIMENSIONS

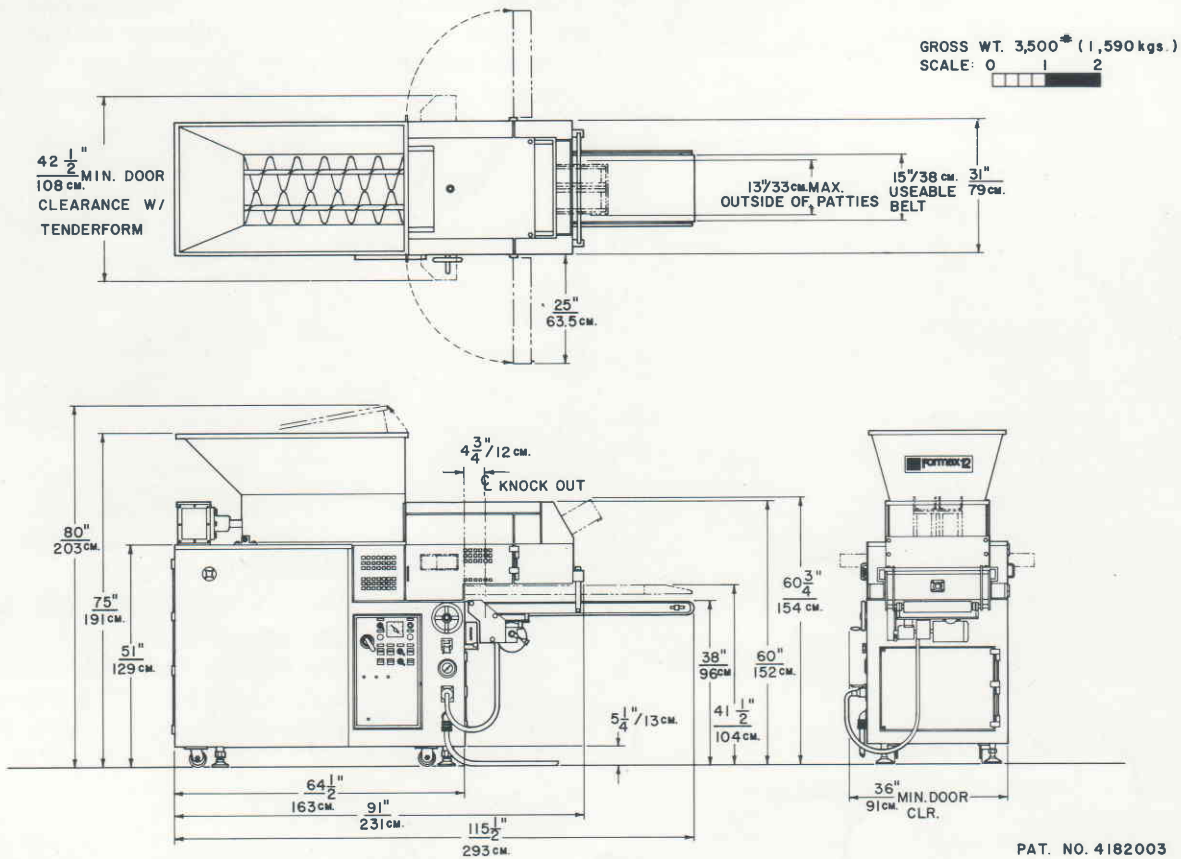

Formax®