

600 LB

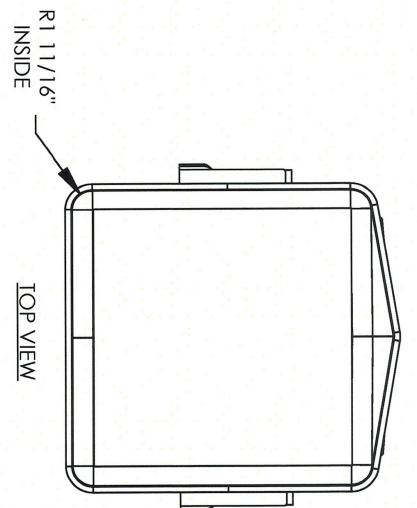
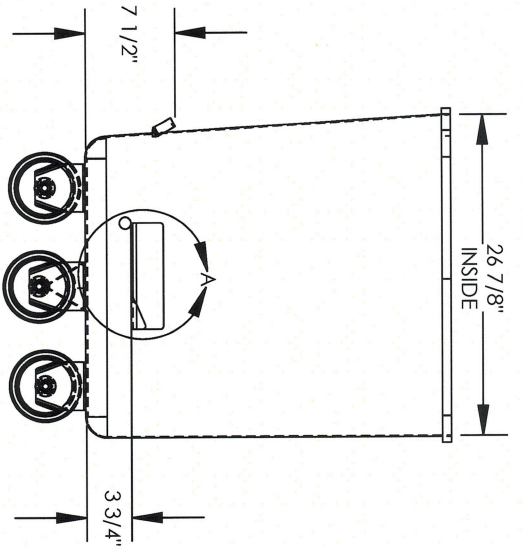
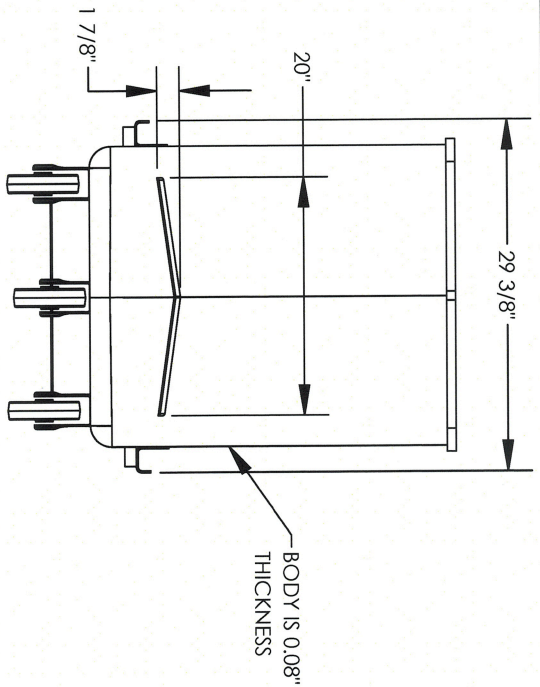

BACK VIEW

SIDE VIEW

TOP VIEW

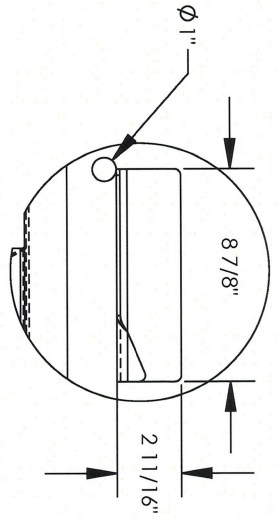
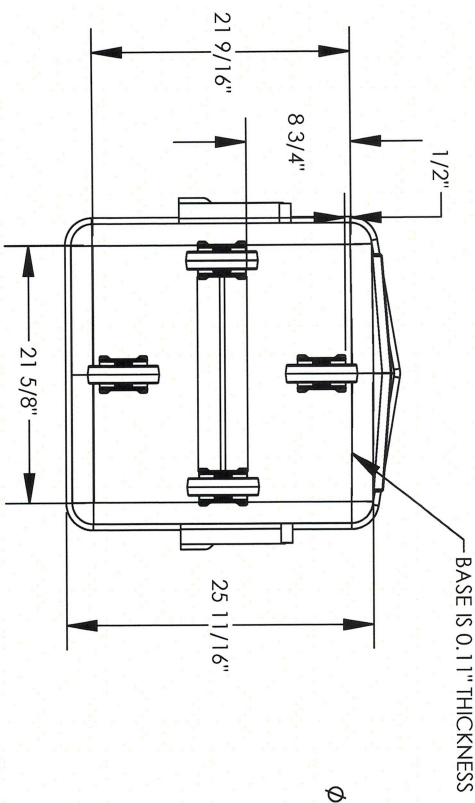

FRONT VIEW

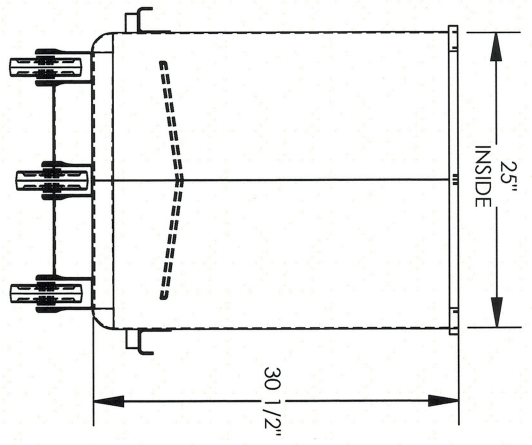

UNLESS OTHERWISE SPECIFIED:
DIMENSIONS ARE IN INCHES

TOLERANCES:
FRACTIONAL ± 1/16"
ANGULAR MACH ± .5° BEND ± 2°
TWO PLACE DECIMAL ± .015"
THREE PLACE DECIMAL ± .005"

MATERIAL: -

DRAWN BY: A. RUSCH

FINISH:

DATE CREATED: 6/28/2022

WEIGHT: 109.907 (LB)

LAST SAVED: 7/17/2023

NOTE: DEBURR AND BREAK ALL SHARP EDGES!

PART NUMBER: DUMP BUGGY ASSEMBLY REV101
DUMP BUGGY ASSEMBLY

SCALE: 1:16

SHEET 2 OF 2

400 LB

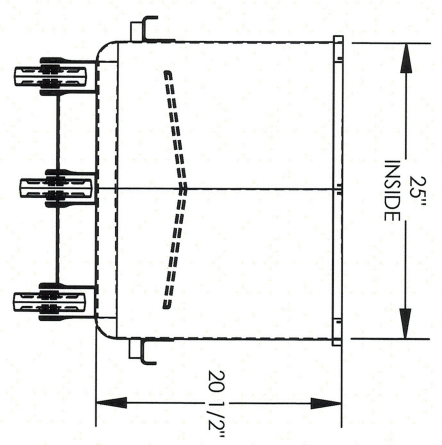
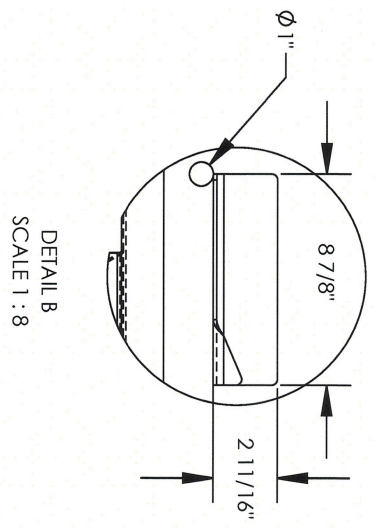
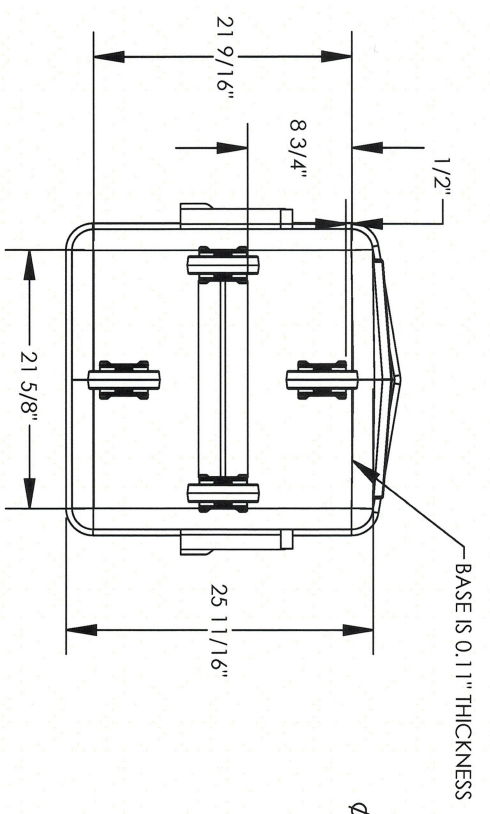
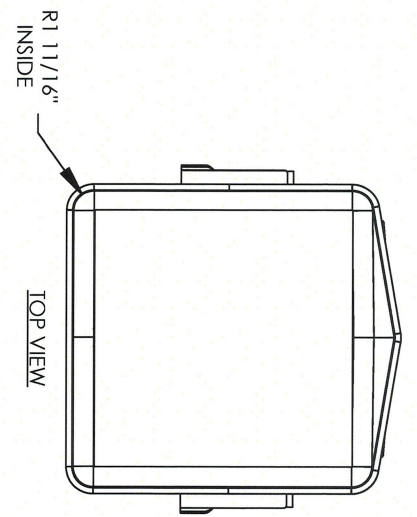
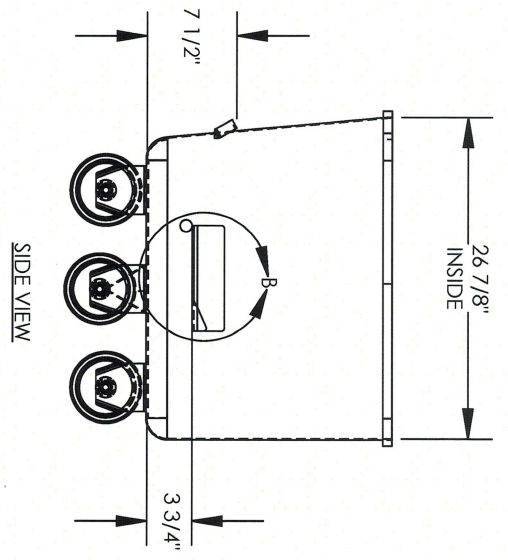
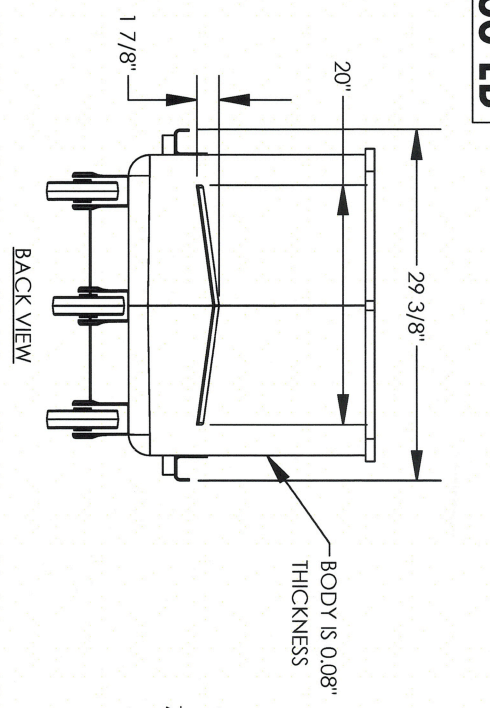

UNLESS OTHERWISE SPECIFIED: DIMENSIONS ARE IN INCHES TOLERANCES: FRACTIONAL: ± 1/16" ANGULAR: MACH ± .5° BEND ± 2° TWO PLACE DECIMAL: ± .015" THREE PLACE DECIMAL: ± .005"		[REDACTED]	
MATERIAL: -	DRAWN BY: A. RUSCH	[REDACTED]	
FINISH:	DATE CREATED: 6/28/2022	[REDACTED]	
WEIGHT: 88.744 (LB.)	LAST SAVED: 7/17/2023	[REDACTED]	
NOTE: DEBURR AND BREAK ALL SHARP EDGES!		[REDACTED]	
PART NUMBER: DUMP BUGGY ASSEMBLY REV101		[REDACTED]	
DUMP BUGGY ASSEMBLY		[REDACTED]	
SCALE: 1:16		SHEET 1 OF 2	