

ANSICHT "A" / VIEW "A"

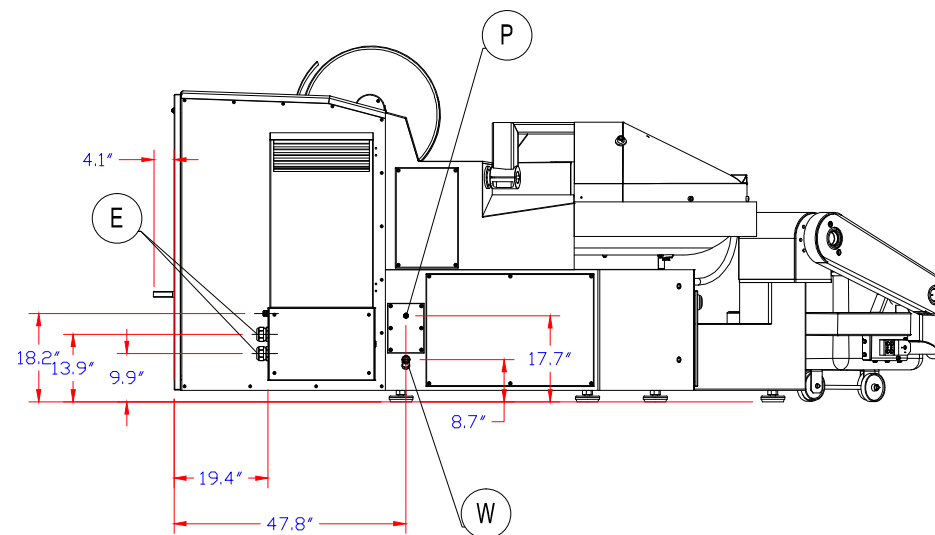

POWER : 460V, Three Phase, 60Hz,			
KNIFE SHAFT MOTOR	140 kw	187 hp	295 Amps
BOWL SHAFT MOTOR	1.5 kw	2.0 hp	2.6 Amps
Full Load			298 Amps
Recommended Circuit			450 Amps

DIMENSION SHEET

name: Kutter / Cutter		type: K330 N AC - KU(X)		customer / country: - /	
information: Schaltschrank intern / inside cabinet - Auswerfer Rechts / ejector right - Standard / standard - mit Hydraulischer Beschickung / with hydraulic loading hoist - ohne Kühlung / without cooling		machine number: -		SEZ / NAR: -	
Urheber- und Schutzrechte dieser Pläne bleiben uns vorbehalten. Vervielfältigung und Weitergabe nur durch unsere schriftliche Zustimmung.		Maschinenfabrik LASKA Gesellschaft m.b.H. Makartstraße 60, 4050 Traun - Austria T +43 7229 / 606-0 laska@laska.at		first-angle projection	
		all dimensions in mm do not scale this dwg		model: K0334 / 94000	
		sheet: 1 / 2		drawn: msou	
		scale: 1:30		2018.03.01	
		drawing number: K0334-00020		LASKA	

Technische Daten / technical data

Schüsselinhalt	bowl volume	[ltr]	330
Abmessungen & Gewichte Maschine / dimensions & weights machine			
Abmessungen L x B x H	dimensions L x W x H	[mm]	4160 x 3135 x 1860
Einbringmaße H x B	minimal height and width for transport H x W	[mm]	1960 x 1880
Mindestraumhöhe	minimum ceiling height	[mm]	2800
Netto - Gewicht ca.	net - weight approx.	[kg]	4650
Brutto - Gewicht ca. inkl. Verpackung ¹	gross - weight with packing approx.	[kg]	5400
Gewicht pro Maschinenfuß ca. ²	weight per machine foot approx.	[kg]	1220

¹... Seekiste / case
²...ohne Material / without material

Elektrische Daten / electrical data AC - 3x400V / 50Hz

Ausführung	model	[-]	KU	KUX
Nennleistung	rated power	[kW]	158	166
Nennstrom	rated current	[A]	387	414
Sicherung träge	fuse	[A]	400	400
Zuleitungsquerschnitt	feed pipe cross section	[mm ²]	240	240

Versorgungsanschlüsse / supply connections

Elektrischer Anschluß	electrical connection	E	2x M63x1,5	41 - 54 mm
Wasseranschluß ¹	water connection ¹	W	1"	2 - 6 bar
Druckluft	pressurised air	P	Ø9 mm	6 - 10 bar

¹ optional / option

DIMENSION SHEET

customer / country:

- /

name: Kutter / Cutter		type: K330 N AC - KU(X)		machine number: -		SEZ / NAR: -	
information: Schaltschrank intern / inside cabinet - Auswerfer Rechts / ejector right - Standard / standard - mit Hydraulischer Beschickung / with hydraulic loading hoist - ohne Kühlung / without cooling				first-angle projection 		model: K0334 / 94000	
				all dimensions in mm do not scale this dwg		drawn: msou	
Maschinenfabrik LASKA Gesellschaft m.b.H. Makartstraße 60, 4050 Traun - Austria T +43 7229 / 606-0 laska@laska.at				sheet: 2 / 2		scale: 1:1	
				drawing number: K0334-00020		