



**poly-clip<sup>®</sup>**  
**SYSTEM**

**PDC**  
**600/700**

**AUTOMATIC**  
**DOUBLE**  
**CLIPPER**



**The professional clippers for small and midsize operations**

- 2 machine sizes for different product ranges:  
PDC 600 for calibres up to 80 mm  
PDC 700 for calibres up to 115 mm
- For all plastic, fibrous, collagen and natural casings
- Upgrade to optional features at any time
- Designed to be flexible – as a table-top model or on a trolley

**innovative · reliable · leading**

# THE RIGHT MACHINE FOR ALL TYPES OF PRODUCT

## AUTOMATIC DOUBLE CLIPPERS, SERIES PDC 600

### Application

The PDC 600 and PDC 700 automatic double clippers are suitable for all sizes of operations – for small or large production runs. They close any plastic, fibrous, collagen or natural casing in diameter up to 80 mm (PDC 600) or up to 115 mm (PDC 700). Using the PDC means that all products – single portions or chains, long sausages, half rings and rings – can be produced efficiently.

### Advantages

- Can be modified when needed
  - modular construction
- Upgrade to optional features at any time
- High performance with a low price
- For all casings and all products
- Hygiene
  - made completely of stainless steel and industrial plastic
  - smooth surfaces make it easy to clean
- Very easy to use



Products with diameters up to 80 mm in diameter can be produced quickly and safely with the PDC 600.

- Height adjustable
- Adjustable clip pressure
- Designed for flexible use – as table-top model or on trolley
- Space-saving; trolley fits to any existing table

- Lightweight

### Optional equipment

- Manual or automatic loop-insertion (GSE) for tape-less loops
- String dispenser
- Mechanical and electrical filler-coupling
- Movable and pneumatical casing brake
- Height-adjustable trolley
- Control for chubs in a chain
- Discharge with product stop
- Pivoting clipping head
- S-clips from a roll
- Labelling System ES 4000



PDC 600 with string dispenser placed in front of the filler. Up to 40 kg of sausage in 5 minutes can be produced easily.



The clip pressure can be adjusted perfectly.



# CTS: + PDC 700



*Simple and safe: marking by embossed labels*



*The PDC 700 closes all diameters up to 115 mm.*

## Function and operation

PDC 600 and PDC 700 automatic double clippers can be placed as required in front of the filler or coupled mechanically with the filler; electrical coupling is possible in addition. When the operator closes the

handle, the filled casing is centered, separated and double-clipped. At the same time the casing can be cut either automatically via the chain control or by pressing a button. For hanging-up the sausages,

tapeless loops can be inserted and clipped, either manually or automatically.



*Loops may either be inserted manually or fed and clipped automatically.*



*The separator is adjustable and can be adapted to any product. This ensures an attractive product appearance.*

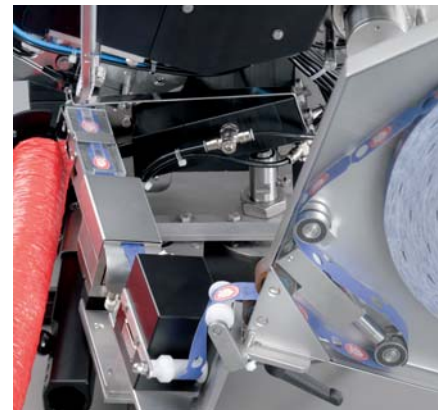

*The labels can be supplied pre-printed – with individual data or as decorative label.*

# TECHNICAL DATA

Dimensions (in mm)

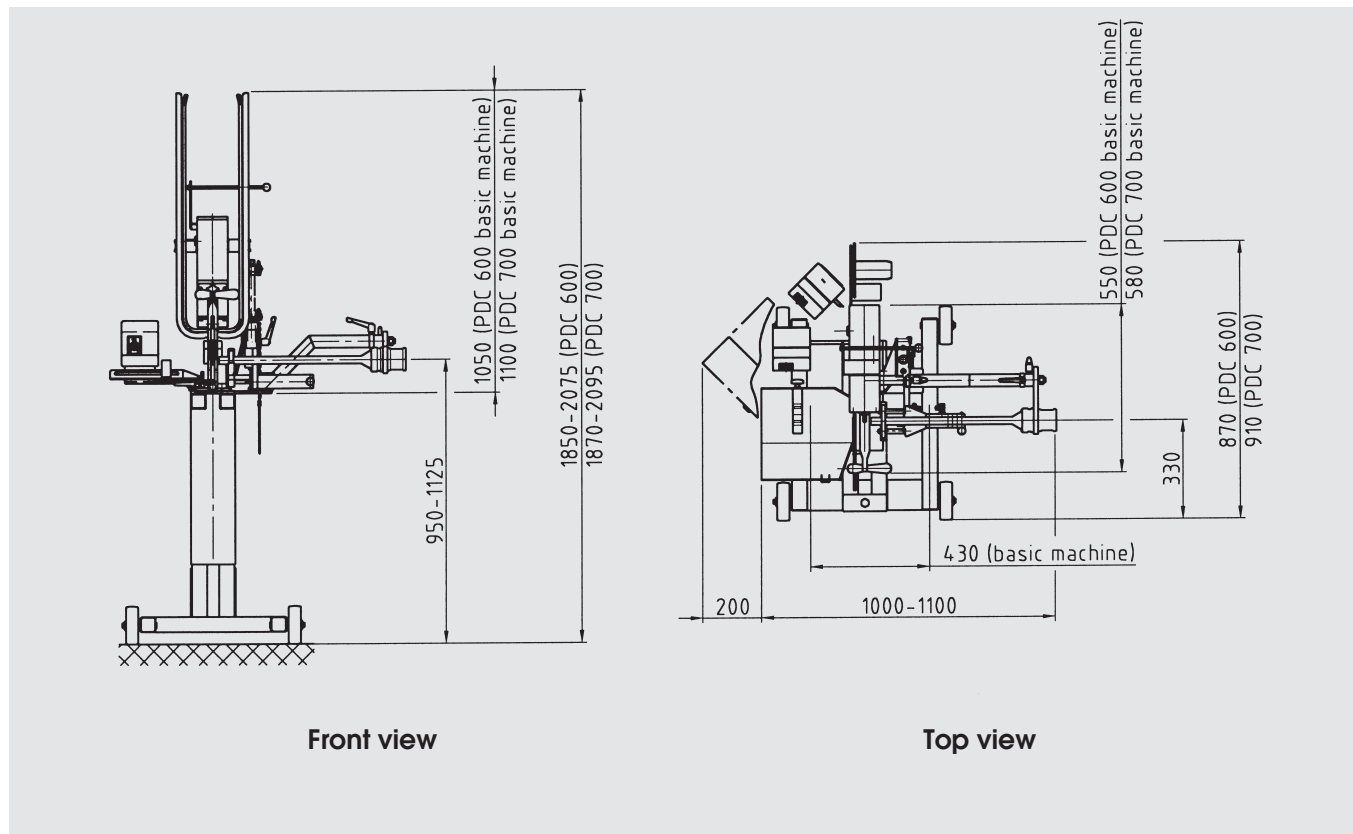

## Technical Data

	PDC 600 (basic machine)	PDC 700 (basic machine)
Width:	430 mm	430 mm
Depth:	550 mm	580 mm
Height:	1,050 mm	1,100 mm
Weight:	25 kg	30 kg
Compressed air:	5 bar/0.5 MPa	5 bar/0.5 MPa
Air consumption:	5.5 NL/cycle	14.9 NL/cycle
Suitable clip sizes:	S 625/628/632/638	S 735/740/744



**Poly-clip System GmbH & Co. KG**  
 Westerbachstraße 45 · D-60489 Frankfurt  
 Tel.: +49 (0) 69 - 78 06 -0 · Fax: 78 06 -360  
 www.polyclip.com · contact@polyclip.de