

SPECIFICATIONS

MACHINE DIMENSIONS & WEIGHT

Dimensions basic machine (LxWxH)
67.99' x 57.32' x 84.33'
Weight basic machine
1,764 lbs

MOTOR

Power
14.75 hp

CUT SHAPES & SIZES

Cut shapes
Flat cut slices, strips and dices
Cut sizes
Various cut sizes possible:
Slices: from 0.039' up to 1.10'
Strips : from 0.125' up to 1.50'
Dices: from 0.138' up to 3.94'
Capacity
Up to 1,764 lbs / per 0.039' / per hour

APPLICATION SUMMARY

Cheese
Soft, Semi-hard and processed cheese like Mozzarella, Gouda, Cheddar, Emmental, Provolone.
Meat
Bacon, cooked ham, salami end-pieces, cooked beef and fresh and frozen beef/pork/poultry, cured ham. Cut products for use in salads, pizza-toppings, ready prepared meals, meat-snacks, pet-foods and more.
Poultry
Chicken and turkey (breast or thigh meat, fresh-frozen or cooked)

CUTTING PRINCIPLE

The FAM CMD.2 is specialized in cutting small dices and strips with precision. The large product drum allows products up to 8.66' x 11.61'.

The machine is operator-friendly and easy to clean and maintain. The slice thickness is easily adjustable by the manual gauge, and the cutting spindles can easily be removed thanks to the splined shafts.

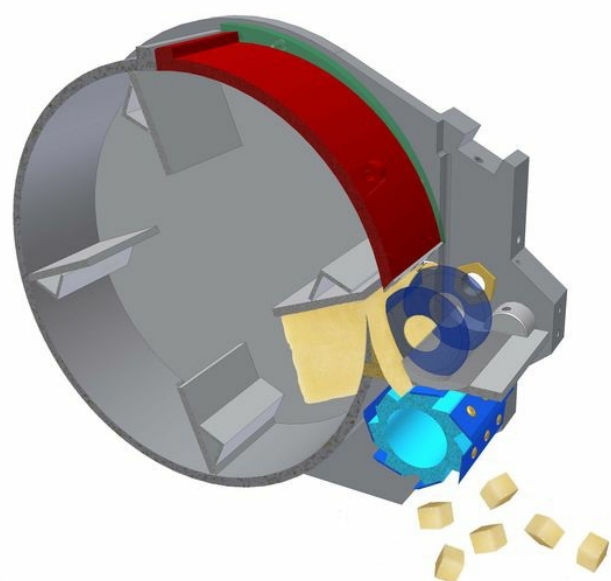

The infinitely adjustable slicing knife first cuts the product in slices. Next, the circular knives cut the slices in strips. Finally, the crosscut knife spindle cuts neat dices to the desired height.

The combination of three cutting tools allows a very high flexibility in the choice of cutting sizes and shapes. For the different applications, a wide variety of slicing knives, circular knives and crosscut knives is available.

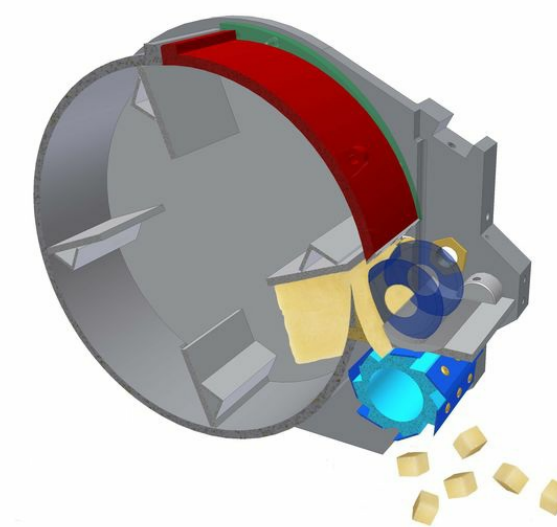
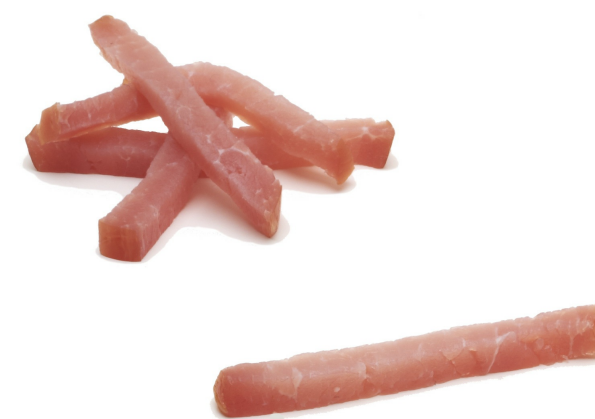

 Meat

 Cheese

The FAM CMD.2 is an outstanding high-capacity dicer for cooked, chilled or frozen meat and poultry.

Cutting Trials

Worldwide, FAM is ready to advise you in one of its fully equipped test centres. You are invited to send us products for evaluation and you are most welcome to be present during the trials.

FAM nv

Neerveld 2
B-2550 Kontich - Belgium
t. +32 3 450 92 20
f. +32 3 450 92 50
e. info@fam.be

Contacts and Information

For a complete overview of our machines, applications, services and agents, please visit our website. FAM will be happy to respond immediately to your information request.

Member of 



FAM is a registered trademark of FAM nv.

Your Local Contact

DEVILLE TECHNOLOGIES INC.

8515 Henri-Bourassa W.
Montreal, Quebec H4S 1P7,
Phone: +1.514.366-4545
Fax: +1.514.366-9606
E-mail: info@devilletechnologies.com
Website: www.devilletechnologies.com
Ask for a trial or demonstration

KEY FEATURES

Very effective cutting principle for continuous high-capacity slicing, strip-cutting and dicing of various products.

Superior, attractive cut quality with only few fines as the product is not forced through the cutting mechanism, but cut with fast rotating knife spindles.

Features continuous operation for high-production capacities, for example 6,614 lbs per hour on 0.236" bacon dices or 2,646 lbs per hour on 0.118" mozzarella dices.

Large product drum handles big blocks of cheese or meat in square, rectangular or cylindrical form, reducing the need for pre-cutting.

Heavy-duty cutting tools allow to save time and energy, while maintaining low processing temperatures (down to depending on the application).

The electrical and electronic components are safely stored in a cabinet located at the backside of the machine, far away from the wet zone.

Quick changeover of the circular and crosscut knife spindles thanks to the use of splined shafts.

Hinged swivel slicing gate facilitates easy and thorough cleaning of the inside of the product drum.

The drive zone and the product zone are completely separated by a watertight separation.

Auxiliary tool available for the safe mounting and demounting of the knife spindles and special support tool for the the impeller.



HIGHLIGHTS

- Features continuous operation for high-production capacities.
- Superior cut quality resulting in a very attractive appearance of the cut product with only few fines.
- Low processing temperatures result in a non-sticky cut product which facilitates weighing and packing.
- Equipped with large product drum for large input sizes of blocks of meat and cheese in square, rectangular or cylindrical form.
- All stainless steel construction and sanitary design with no sharp edges or projecting parts, thus effectively eliminating "dirt traps".

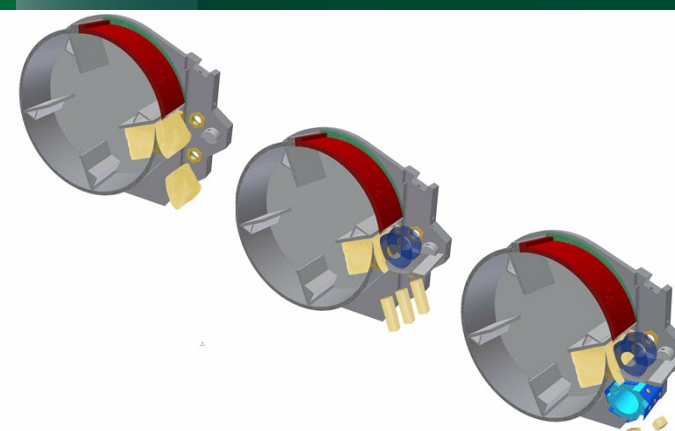

Very effective cutting principle for continuous high-capacity slicing, strip-cutting and dicing of various products.



Superior, attractive cut quality with only few fines as the product is not forced through the cutting mechanism, but cut with fast rotating knife spindles.

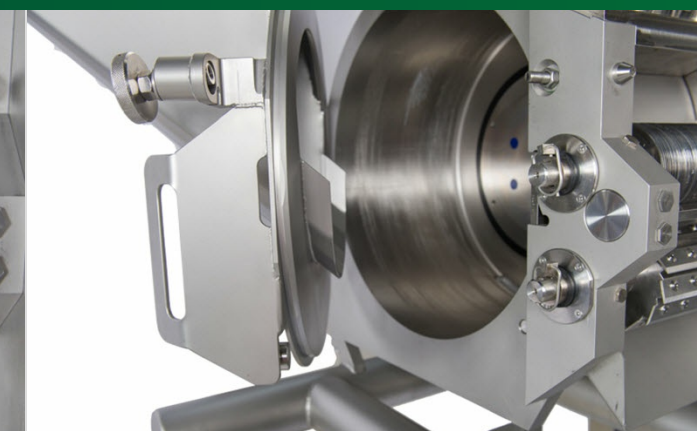

Large product drum handles big blocks of cheese or meat in square, rectangular or cylindrical form, reducing the need for pre-cutting.



The electrical and electronic components are safely stored in a cabinet located at the backside of the machine, far away from the wet zone.



Quick changeover of the circular and crosscut knife spindles thanks to the use of splined shafts.



Hinged swivel slicing gate facilitates easy and thorough cleaning of the inside of the product drum.



The drive zone and the product zone are completely separated by a watertight separation.

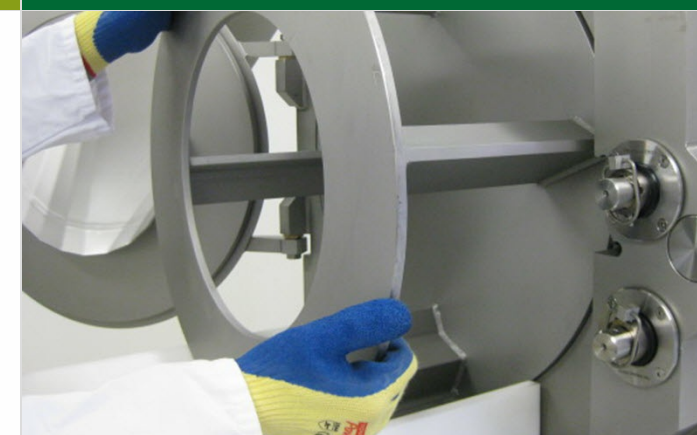

Auxiliary tool available for the safe mounting and demounting of the knife spindles and special support tool for the the impeller.



Strips Cured Ham



Ham Strips



Ham Dices



Salami Dices



Bacon Dices



Gouda Dices



Cheddar Dices



Cheddar Shreds