

TYPICAL SINGLE PACKAGE
TOP VIEW

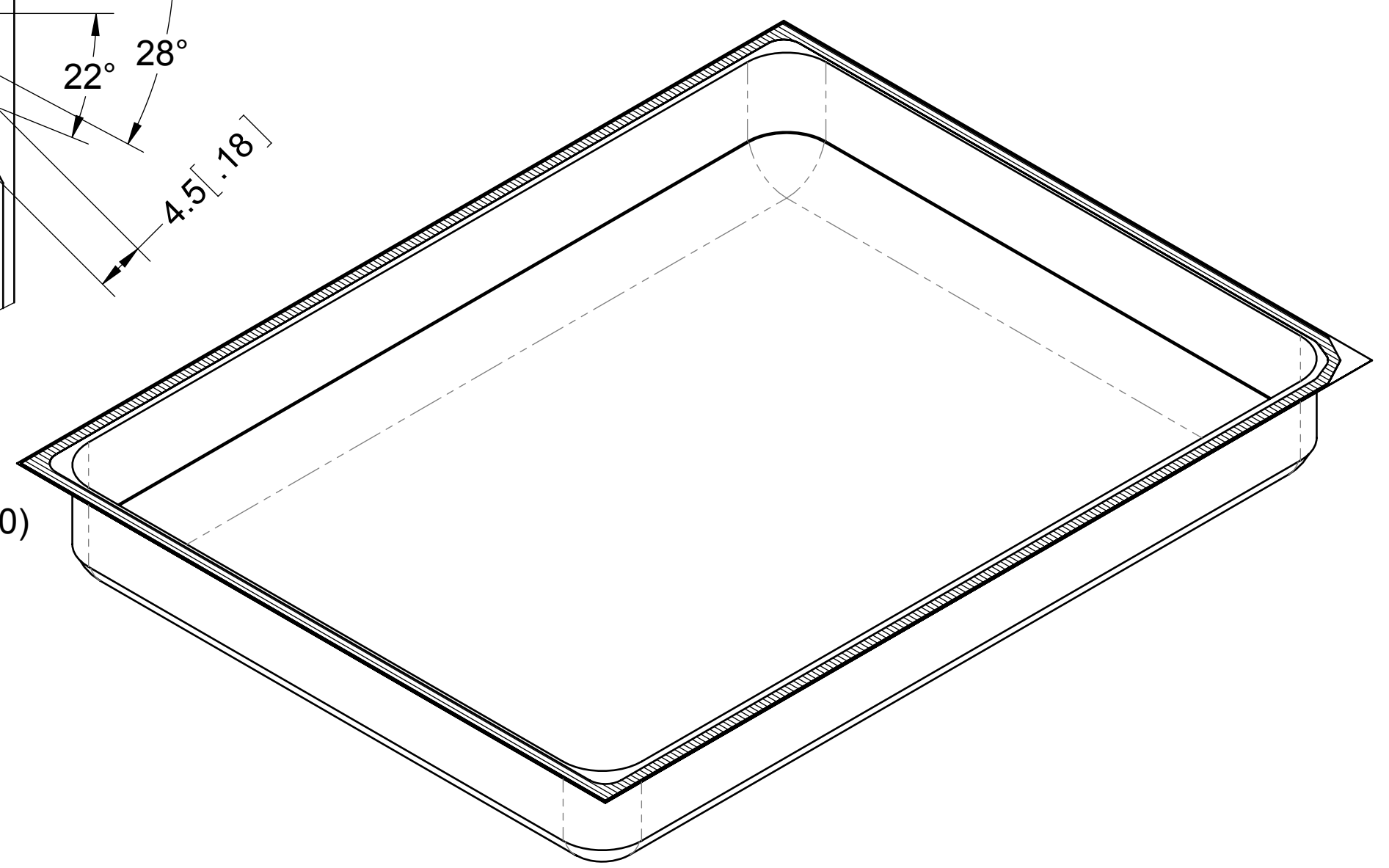
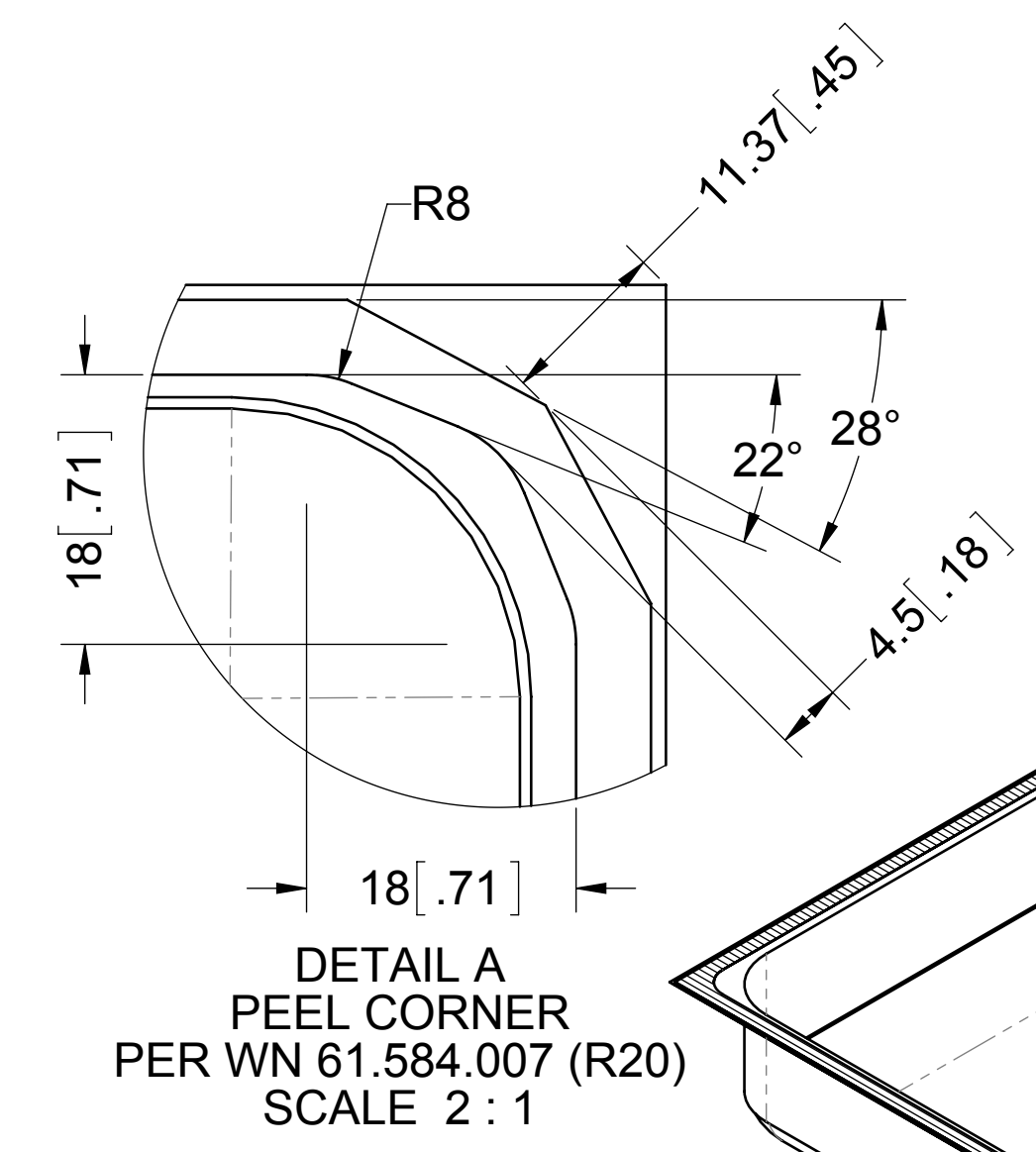
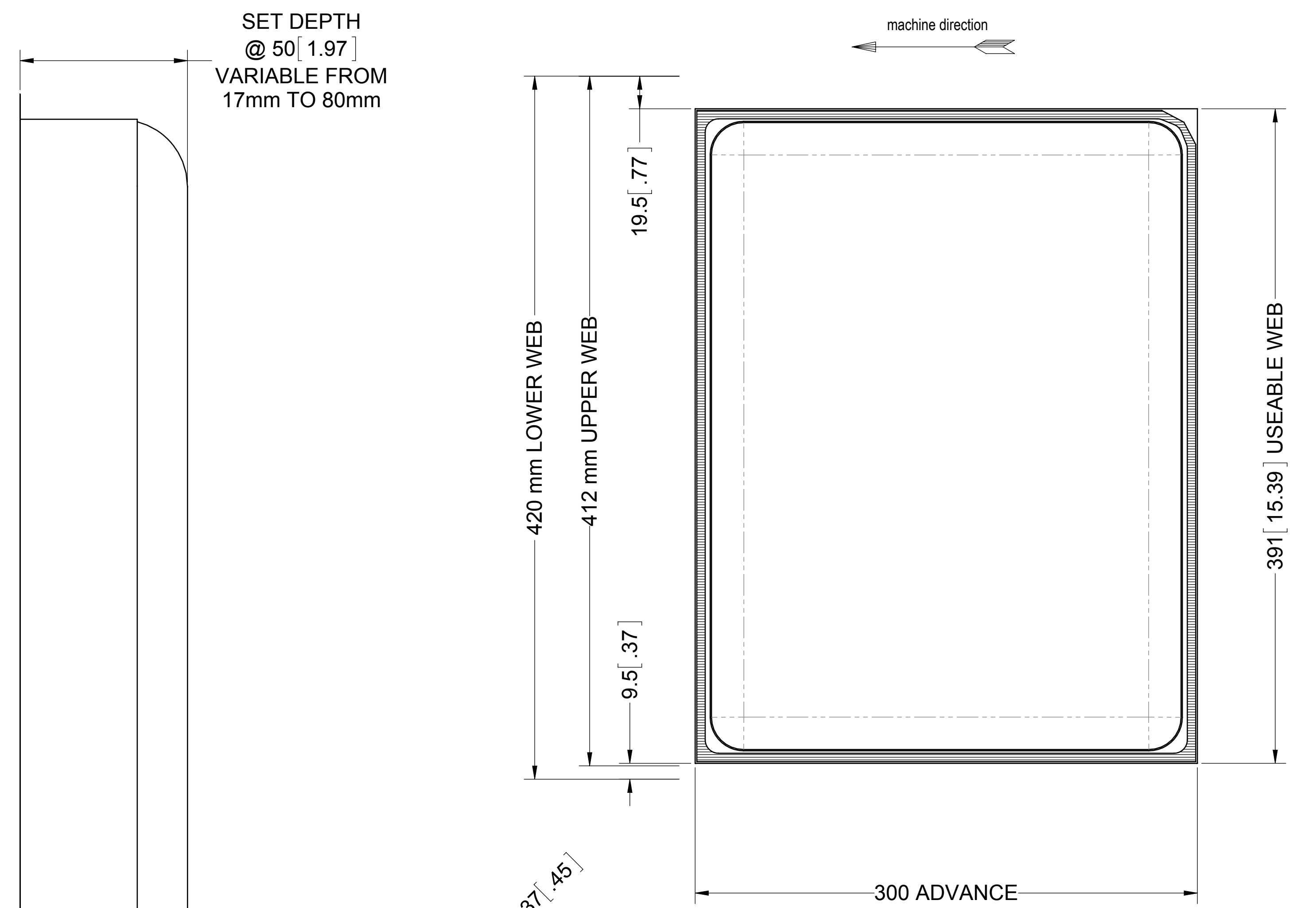

U.S.A.

PROTECTION NOTICE ISO 16016
The reproduction, distiution and utilization of this document as well as the communication of its contents to others without express authorization is prohibited. Offenders will be held liable for the payment of damages. All rights reserved in the event of the grant of a patent, utility model or design.

The dimensions of the package blister are the inside dimensions of the forming mold. The inside dimensions of the blister are reduced due to film thickness and shrinkage properties of the package material.

PACKAGE DESIGN NOTES
ALL DIMENSIONS ARE IN MILLIMETERS
DUAL DIMENSIONS ARE IN INCHES

NOTICE:
PACKAGE DEPTH IS LIMITED BY MATERIAL FORMABILITY AND TOOLING CONSTRUCTION.

SEALING NOTE:
MINIMUM MEASUREABLE SEAL IS 3.5mm

DESCRIPTION:
1T1R PACKAGE ARRAY

CREATED BY: kkeever DATE: 21.4.2015

CHANGED BY: kkeever DATE: 21.4.2015

CHANGE NUMBER: CHANGE DESCRIPTION:



MULTIVAC, INC.
11021 N. POMONA AVENUE, KANSAS CITY, MO 64153
TEL: 816-891-0555

ANSI SIZE | SCALE
D | 1:1

SHEET 1 OF 1

CUSTOMER NAME:
ORNNA FOODS

DOCUMENT NUMBER: 15000216034

REV: 0