



PRODUCT CATALOGUE

EXCELLENCE IN PROCESSING



günther®

GÜNTHER MASCHINENBAU

PORTRAIT OF A SPECIALIST

FACTS ABOUT GÜNTHER MASCHINENBAU GMBH

- ⊕ Founded in: 1980
- ⊕ Representation in 105 countries, and on all continents
- ⊕ New 9000 m² production area in 2021
- ⊕ Average number of machines sold: 550 p. a.

Günther Maschinenbau develops and manufactures high-tech solutions for food processing. The focus of our range of services is on machines and systems for curing, tumbling, mixing, steaming and coating. Whether meat, poultry, fish, cheese, convenience or vegetarian products, we know the special requirements for these products and offer our customers the best possible technology for processing in each case.

With our new customer centre, we are responding to the increasing demand from our customers for a suitable development environment for new products and manufacturing processes. Using your original raw materials, you can test the manufacturing of new end products together with our technologists, optimize them in terms of quality and cost, or produce samples. In our customer centre we also offer solutions to improve product quality and production efficiency for products already on the market. In addition, FAT tests (Factory Acceptance Tests) are carried out. Here you have the opportunity to put your production line through its paces one last time before delivery.

CONTENTS

WHAT MAKES GÜNTHER MASCHINENBAU SPECIAL?

..... » see **p. 4**

APPLICATIONS

..... » see **p. 6**

I INJECTORS

For injecting meat, poultry, fish and cheese
..... » from **p. 10**

T TUMBLERS

Tumbling, maturing, mixing, salting, thawing, coating and marinating
..... » from **p. 24**

B BRINE PREPARATION

Mixing tanks and automated brine treatment plants
..... » from **p. 36**

S ROLLERS AND KNIFE STEAKERS

Roller and knife steakers for refining your product and preparing it for further processing
..... » from **p. 48**

C GÜNTHER COATING TECHNOLOGY

Refining of products with sauces, spices and marinades
..... » from **p. 56**

P PERIPHERIES

Automated solutions for product handling and line operation
..... » from **p. 62**

TECHNOLOGY, SOFTWARE, HYGIENE

..... » see **p. 76**

PARTNERS/SERVICE

..... » see **p. 83**

WHAT MAKES GÜNTHER MASCHINENBAU SPECIAL?

12 REASONS FOR A SUCCESSFUL PARTNERSHIP

1

We produce **high quality**,
"Made in Germany" products!

4

Via our software solution for **process data analysis**,
you always have everything under control **remotely!**

2

We respond **flexibly**
to customer requirements!

5

One on one,
with a **partner on an equal footing!**

3

Our **efficient machines** generate
a quick **return on investment!**

6

As a **technology leader**
we set the benchmark!



7

We have proven ourselves on the market with **fair prices!**

10

We offer you **the best solution** for your production process!

8

We are **environmentally conscious** and rely on renewable sources of energy!

11

At Günther Maschinenbau, you get first-hand **expert knowledge!**

9

Saving energy is our strength and your profit!

12

We focus on the permanent further training of our employees, so that we can guarantee you **the highest level of competence!**





APPLICATIONS

OUR EXPERTISE IN ALL AREAS

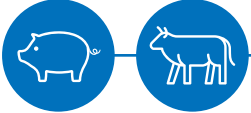

MEAT

Refining the classic favourite

It should always be tender, aromatic and tasty. Shelf life and food safety are therefore the highest priorities. This applies to every meat product, whether breast, silverside, rump or topside of beef or pork, all types of ham and cured pork, whole hams, suckling pigs, grilled meat and much more. This diversity challenges the skills available to the processor and their current technology. Our machines are the best choice for this. You will find a wide range of machines and equipment perfectly suited to the processing of meat. We will be happy to advise you on how to make the most of the possibilities that our technology offers, especially under your production conditions.



POULTRY

Delicate top quality

Poultry products, such as whole chickens, wings, thighs, turkey breasts, chicken breasts, chicken fillets or grilled products always require special treatment when they are to be served on the consumer's plate in a tender, aromatic and appetising presentation. Shelf life and food safety are particularly important criteria for poultry products. From our portfolio, we will find the optimum solution for you to meet these demanding requirements, so you'll be well equipped for the future.



FISH

Very demanding during processing

Hardly any other food is more sensitive than fish when it comes to its shelf life and food safety. If you process salmon, cod, tuna or other species, you'll be well aware of the challenge this poses. You make just as few compromises in this respect as you do when it comes to tenderness, taste and flavour. We also share this attitude. Our machines are high quality products with which you can produce high quality products.

Our numerous satisfied customers are proof that our machines are outstandingly suited for the fish sector. Feel free to contact us – we are at your disposal with advice and support for your tailored solution.



APPLICATIONS

OUR EXPERTISE IN ALL AREAS



VEGETARIAN/VEGAN PRODUCTS

No longer a niche product

Vegetarian and vegan products have long been more than just an alternative; they are a growing market segment that we have been successfully supplying for years. When processing vegetarian and vegan products, processes such as adding flavours or mixing salads, guacamole, meat substitutes and the like are of particular importance. Our experience and technologies allow you to achieve your desired results with these products.

Take advantage of this experience! We will be pleased to show you how you can benefit from this growth market with Günther technology.



DAIRY PRODUCTS

Creating variety and reducing production times

Regardless of which foods you produce from the basic ingredient of milk, the result is always a healthy product in high demand. We ensure economical processes through efficient and safe Günther technology.

Whether you want to inject ripening enzymes and/or starter cultures into cheese, or to mix quark, yoghurt or fresh cheese in larger quantities, we will support you in the decisive production steps.

Our machines and systems are perfectly suited to injecting and processing cheese. Using Günther technology, it is possible to significantly reduce ripening times without changing the taste of the product.



CONVENIENCE FOOD

Natural and environmentally conscious

Various Günther products are not just a great support for you when mixing potato salads, fruit salads or sauces. They also offer you the best possible way to standardise the production of your dishes in perfect quality.

Günther's high-performance coating technology eliminates the need for preservatives and is therefore the simplest and most natural way to always maintain the quality and freshness of your products until they are consumed.

Your ingredients, such as spices, marinades and sauces, are introduced and flash-frozen directly during processing to lock in the natural flavour and freshness of the product.



EXCELLENCE IN PROCESSING •





INJECTORS

FOR INJECTING MEAT, POULTRY, FISH AND CHEESE

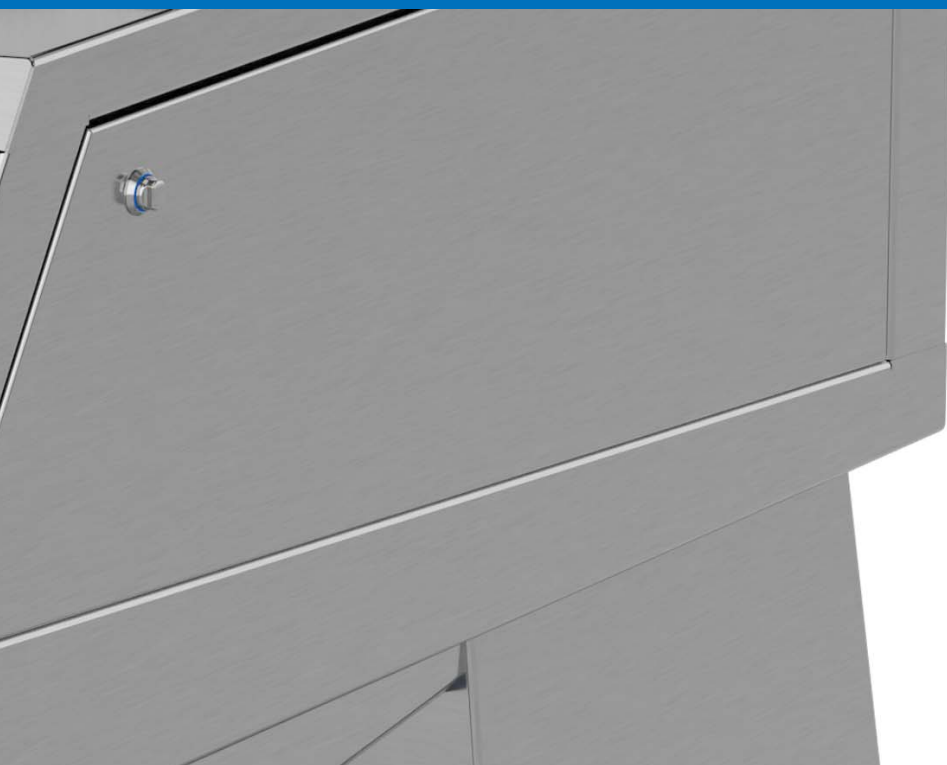

EXCELLENCE IN PROCESSING



MORE INFORMATION?
Visit the section
on our website.

INJECTORS

FOR INJECTING MEAT, POULTRY, FISH AND CHEESE

You always get the best out of your products – better still, you inject them! With our injectors you have the perfect tool to refine your products with spices and additives. Add increased shelf life and taste to your products by working with sophisticated, durable technology that meets the highest standards.

YOUR BENEFITS

- ⊕ Taste enhancement through injected flavours
- ⊕ Improved colour tones and shelf life by utilising injected salts
- ⊕ Uniform reddening and longer shelf life
- ⊕ Improved product consistency
- ⊕ Higher yield when slicing
- ⊕ Juicier consistency and better tasting end product



PP2-PP3

The handy all-purpose injector

» from **p. 14**



PI 265-345

The automated solution for small and medium-sized businesses

» from **p. 16**



PI 365-900

The answer to your industrial needs

» from **p. 18**



PI 365-605 DOUBLE HEAD

The precise high-performance injector

» from **p. 20**

EXCELLENCE IN PROCESSING

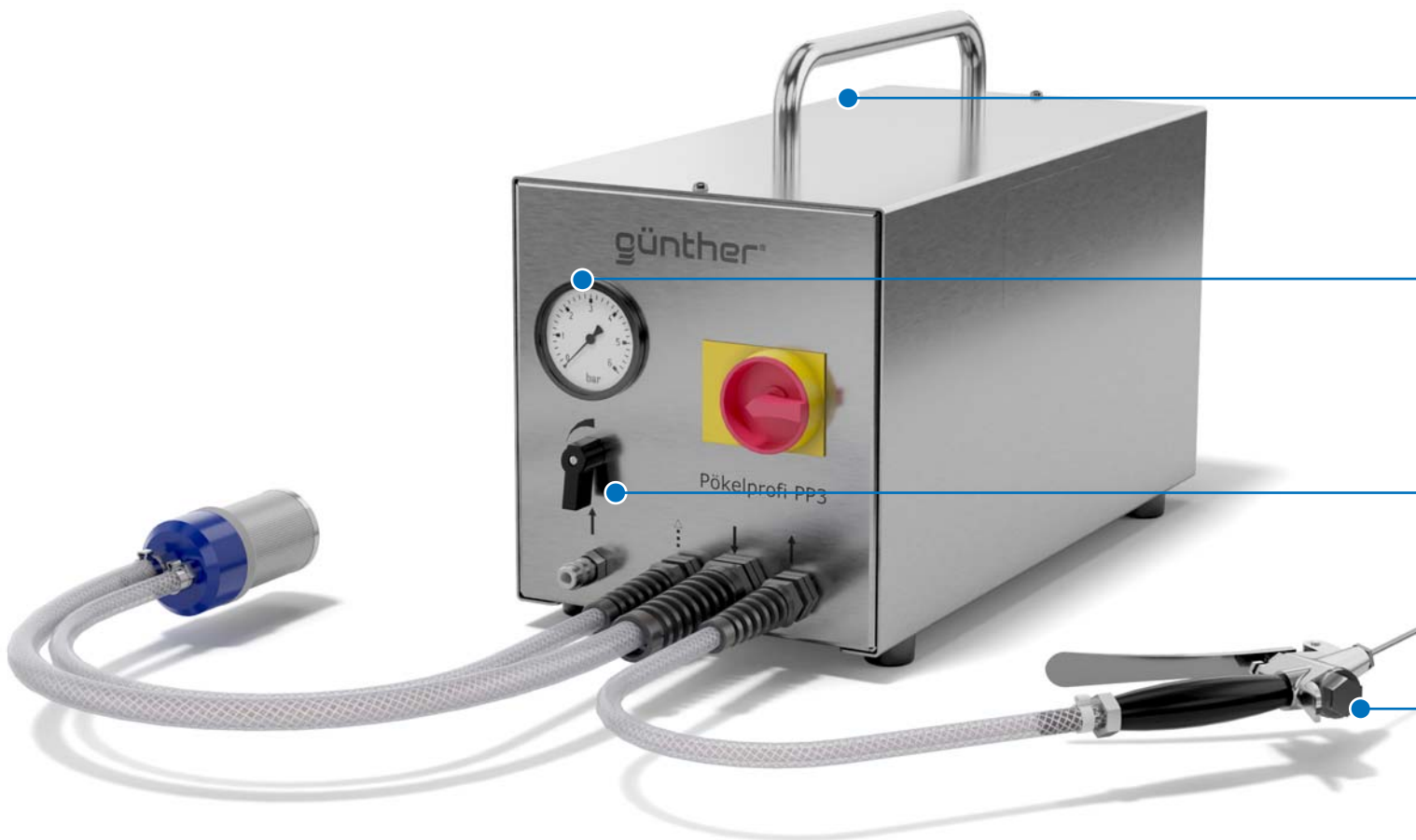

MORE INFORMATION?

Visit the section
on our website.

PP2 – PP3

THE HANDY ALL-PURPOSE INJECTOR

The small all-purpose injector for lower production volumes, also ideally suited for test productions and special applications.

EASY-CARE DESIGN

- Easy to clean
stainless steel frame

INCREASED PRODUCTION RELIABILITY

- Self-priming pump
with exact pressure indication by manometer

EASY OPERATION

- Easy to handle
through manual pressure regulation

EFFICIENT ADDITIONAL EQUIPMENT

- Optimised working using
3 or 6 needle robe (optional)
and handhold connection

	PP2	PP3
Number of needles	1	1
Dimensions in mm (length/width/height)	500/210/270	670/230/330
Connection values (standardised)	0.18 kW, 1.9 A, 230 V, 1 PH/N/PE	0.5 kW, 1.5 A, 400 V, 3 PH/PE

EXCELLENCE IN PROCESSING

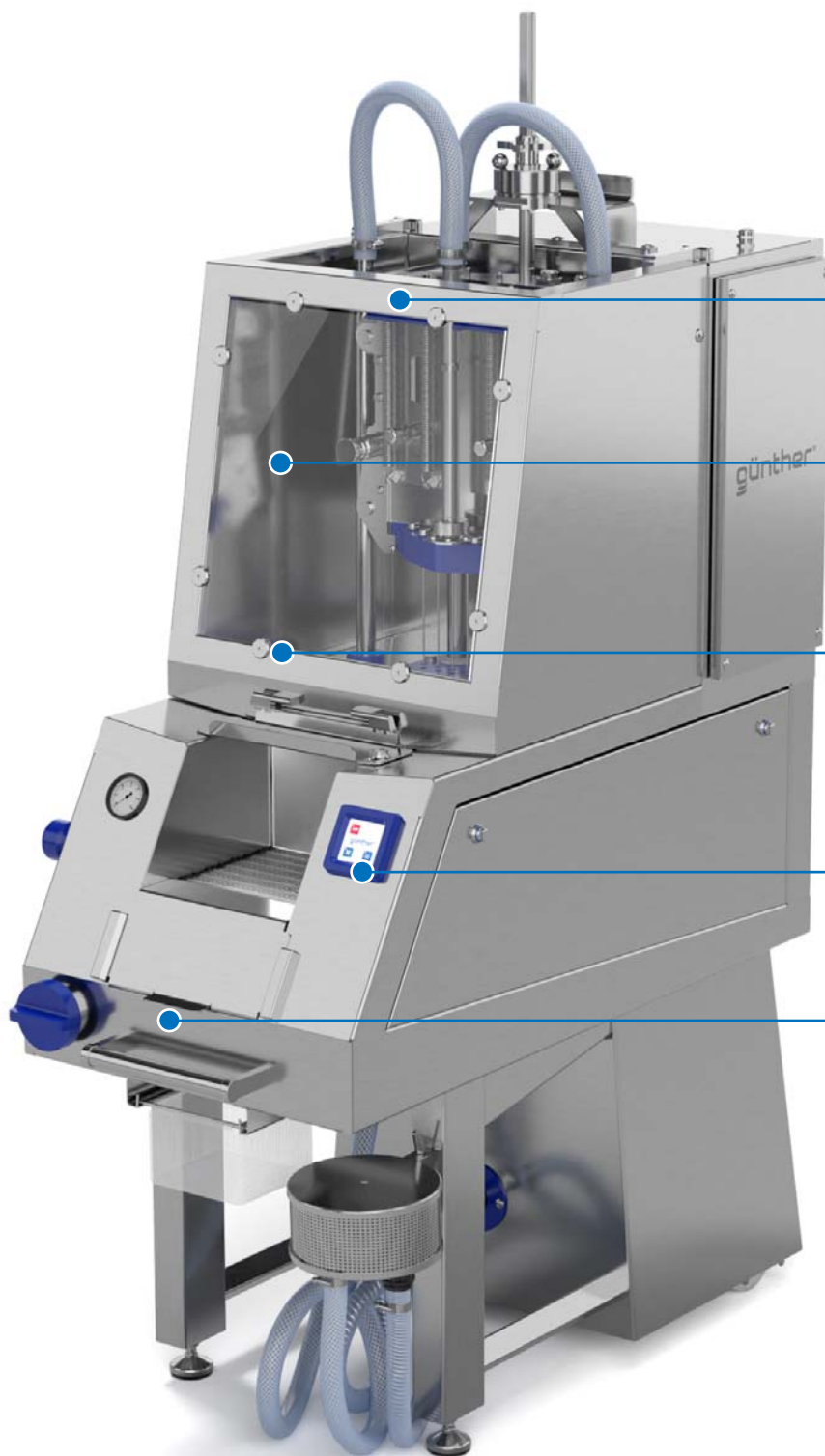

MORE INFORMATION?

Visit the section
on our website.

PI 265 – 345

THE AUTOMATED SOLUTION FOR SMALL AND MEDIUM-SIZED BUSINESSES

Our automatic trade injectors have been designed based on industrial machines, for the requirements of artisan and medium-sized businesses.

INCREASED MACHINE SERVICE LIFE

- Separate dry and wet areas

EASY AND THOROUGH CLEANING

- Mechanical quick-change needle system with controlled precision injection

ABRASION-FREE AND SAFE PROCESSING

- Food-certified high-hygiene belt
- No heat input into the cooled brine due to separation of heat-radiating parts from brine-conveying components

INTUITIVE PROGRAM CONTROL

- Simple setting of machine parameters

BEST BRINE FILTRATION

- Use of suction filter, pre-filter and return flow filter

	PI 265-17	PI 280-21	PI H-F 280-57	PI 345-26	PI-H 345-52
Belt width in mm	265	280	280	345	345
Needle designs	17	21	57	26	52
Capacity in kg/h	1765**	1865*	2117***	2298*	4595*
Throughput in mm	180	210	120/150	210	210
Cycling in 1/minute	60	60	60	60	60
Dimensions in mm (length/width/height)	1420/950/2030	1420/1050/2260	1450/750/2340	1760/1200/2320	1760/1200/2320
Connection values (standardised)	1.9 kW, 16 A, 400 V, 3 PH/N/PE	2.2 kW, 16 A, 400 V, 3 PH/N/PE	2.2 kW, 16 A, 400 V, 3 PH/N/PE	2.2 kW, 16 A, 400 V, 3 PH/N/PE	5.5 kW, 16 A, 400 V, 3 PH/N/PE

* for 210 mm throughput

** for 180 mm throughput

*** for 120/150 mm throughput

EXCELLENCE IN PROCESSING

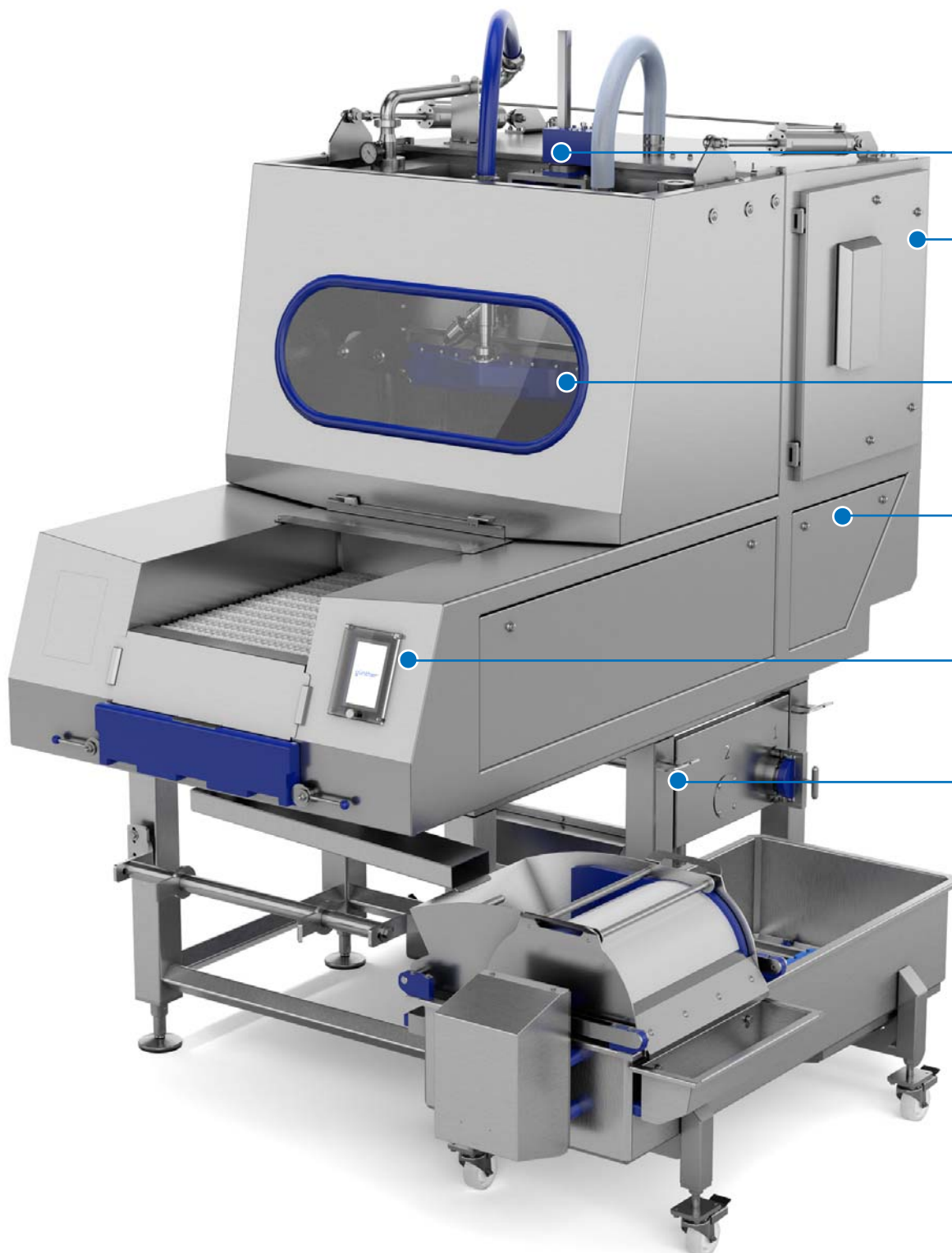

MORE INFORMATION?

Visit the section
on our website.

PI 365 – 900

THE ANSWER TO YOUR INDUSTRIAL NEEDS

Our PI 365 to 900 automatic industrial injectors have been perfectly designed for industrial requirements.

BETTER POWER TRANSMISSION AND MORE PRECISE INJECTION

- Drive above the machine

MAXIMUM PROTECTION OF SENSITIVE COMPONENTS

- Encapsulated construction: box-in-box system

FAST CLEANING AND PRODUCT CHANGE

- Pneumatic needle bridge quick-change system

CLEANING DURING OPERATION

- Pre-filter parallel system for longer production times – especially suited to high-abrasion products

OPTIMAL SETTING OF THE PRODUCT RANGE

- MC2R touch panel control

DRUM BRINE FILTER

- With pre-filter and return flow filter
- Optionally also available as a belt filter system

	PI 365-54/75/105	PI H-F 365-210	PI 480-81/124/184	PI-H-F 480-517	PI 605-102/156/236	PI 605-258	PI 605-354	PI-H-F 605-649	PI-H 900-372-2/630-2
Belt width in mm	365	365	480	480	605	605	605	605	2 x 435
Needle designs	54/75/105	210	81/124/184	517	102/156/236	258	354	649	372-2/630-2
Capacity in kg/h	4052*	4862**	6480*	10800***	8168*	19602*	7351*	11979***	16208**
Throughput in mm	220	140	220	55	220	220	220	55	140
Cycling in 1/minute	50	50	50	50	50	50	50	50	50
Dimensions in mm (length/width/height)	1800/ 1000/ 2500	1800/ 1000/ 2500	2330/ 1270/ 2740	2330/ 1270/ 2740	2610/ 1400/ 2750	2610/ 1400/ 2750	2610/ 1400/ 2750	2610/ 1400/ 2660	3250/ 1910/ 3000
Connection values (standardised)	6.5 kW, 16 A, 400 V, 3 PH/N/PE	16 kW 32 A, 400 V, 3 PH/N/PE	16 kW 32 A, 400 V, 3 PH/N/PE	16 kW 32 A, 400 V, 3 PH/N/PE	16 kW 32 A, 400 V, 3 PH/N/PE	23 kW 63 A, 400 V, 3 PH/N/PE	23 kW 63 A, 400 V, 3 PH/N/PE	23 kW 63 A, 400 V, 3 PH/N/PE	27 kW 63 A, 400 V, 3 PH/N/PE
Compressed air	6–8 bar	6–8 bar	6–8 bar	6–8 bar	6–8 bar	6–8 bar	6–8 bar	6–8 bar	6–8 bar

*for 220 mm throughput

**for 140 mm throughput

***for 55 mm throughput

EXCELLENCE IN PROCESSING



MORE INFORMATION?
Visit the section
on our website.

PI 365 – 605 DOUBLE HEAD

THE PRECISE HIGH-PERFORMANCE INJECTOR

The fully automatic Günther double head injectors with advanced servo technology. Two independently driven needle heads for maximum performance.

REDUCTION OF UNUSED BRINE

- Separate needle head drives for individual product height adjustment

FLEXIBLE APPLICATION

- Günther double head system, optionally as a needle bridge and steaker bridge with a pneumatic needle bridge quick-change system

HIGH INJECTION RATES

- Separate feeding of the needle heads

HIGH PRECISION PRODUCTION PERFORMANCE

- Fast processing of high production volumes

	PI 365	PI 480	PI 605
Belt width in mm	365	480	605
Needle designs	54/75/105	81/124/184	102/156/236
Capacity in kg/h	3241*	5184*	6533*
Throughput in mm	220	220	220
Cycling in 1/minute	50	50	50
Dimensions in mm (length/width/height)	3190/1315/2480	3400/1580/2275	3450/1365/2600
Connection values (standardised)	6.5 kW, 16 A, 400 V, 3 PH/N/PE	16 kW, 32 A, 400 V, 3 PH/N/PE	16 kW, 32 A, 400 V, 3 PH/N/PE
Compressed air	6 bar, 200 l/min	6 bar, 300 l/min	6 bar, 300 l/min

*for 220 mm throughput

INJECTOR ACCESSORIES

FILTER SYSTEMS

Günther Maschinenbau filter systems ensure safe production and longer shelf life of the brine. Solid constituents such as leftover meat or sediment are filtered out to prevent the needles from blocking and ensure smooth production. The production process and product decide which filter variant is used: either the Günther drum filter or belt filter.

YOUR BENEFITS

- ⊕ Uninterrupted production times
- ⊕ No brine waste
- ⊕ Avoidance of poor injection due to blocked needles
- ⊕ High production reliability through quick cleaning
- ⊕ Reproducible production results

GRF – ROTARY FILTER

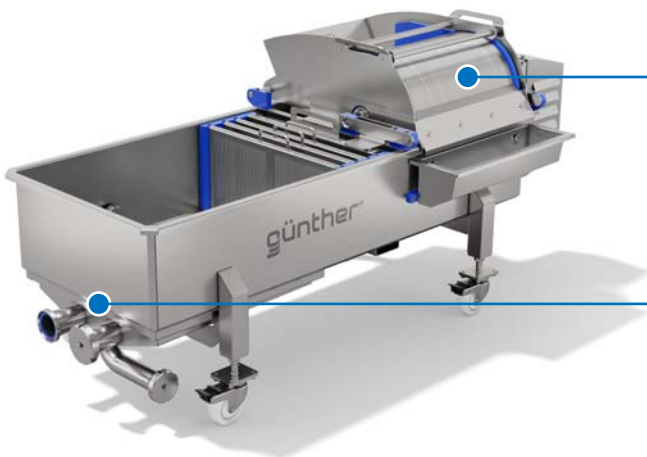

FULLY AUTOMATED DRUM FILTER SYSTEMS

- Mechanically driven rotary filter in various mesh sizes

SOPHISTICATED FILTRATION

- With two insert filters and suction filter at the bottom as standard

GBF – BELT FILTER

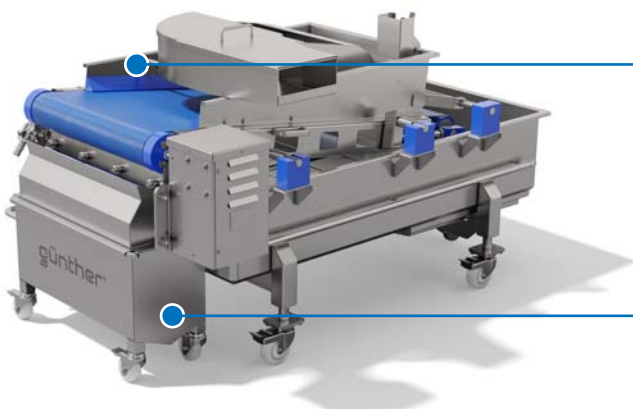

SERVO-DRIVEN FILTER BELT

- Rotating belt plus suction filter at the bottom of the GBF

FULLY AUTOMATIC GÜNTHER BELT FILTER TECHNOLOGY

- Highest filtration, particularly suitable for poultry and fish applications

DRIP AND VIBRATION TECHNOLOGY

Günther's drip and vibration technology has been specifically developed for the continuous and gentle transport of fresh meat, fish and poultry products. Excess brine is collected and fed back into the production process to eliminate brine nests and brine waste.

YOUR BENEFITS

- ⊕ Consistent product results
- ⊕ Juicier end product due to fast closing of the injection channels
- ⊕ No brine waste
- ⊕ Versatile application
- ⊕ Less weight loss

GAT – DRIP TUMBLER



FAST PRODUCT TRANSPORT

- Sophisticated baffle technology

ADJUSTABLE SPEED AND INCLINATION OF TRANSPORT

- Unlimitedly adjustable drum speed

GVT – VIBRATION TABLE

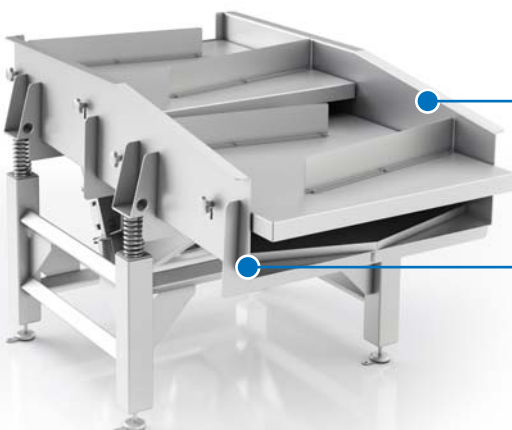

ADJUSTABLE FEED RATE

- Variable angle of inclination of the mechanical table boards

SPACE-SAVING TRANSPORT

- Unique combination of vibration technology in conjunction with product-conveying baffles



EXCELLENCE IN PROCESSING •





TUMBLER

TUMBLING, MATURING, MIXING, SALTING, THAWING AND MARINATING



EXCELLENCE IN PROCESSING



MORE INFORMATION?

Visit the section
on our website.

TUMBLER

TUMBLING, MATURING, MIXING, SALTING, THAWING AND MARINATING

Whether tumbling, mixing or marinating, you are always perfectly equipped with Günther tumblers. The various series and models of energy-efficient and stable tumblers support you in the mechanical processing of your products. With our user-friendly “Made in Germany” machines you are investing in a stable, low-maintenance future.

YOUR BENEFITS

- ⊕ Delicate structure
- ⊕ Uniform colour and quick reddening
- ⊕ Extended shelf life
- ⊕ Juicy and tender bite
- ⊕ Higher yield
- ⊕ Reduction of shrinkage
- ⊕ Better absorption of spices and marinades
- ⊕ Less dripping loss
- ⊕ Better coating of the product
- ⊕ No air pockets
- ⊕ Faster maturing



GPA TUMBLER

The ideal tumbler for small and medium-sized businesses

» from **p. 28**



GPM MIXER

The all-rounder for mixing and marinating

» from **p. 30**



GPB TUMBLER

The space-saving horizontal tumbler for industry

» from **p. 32**



GPS TUMBLER

The industrial, highly efficient solution for high production output

» from **p. 34**

EXCELLENCE IN PROCESSING



MORE INFORMATION?
Visit the section
on our website.

GPA TUMBLER

THE IDEAL TUMBLER FOR SMALL AND MEDIUM-SIZED BUSINESSES

GPA 100 – 600, the tilting tumbler for small and medium-sized businesses. Perfect for tumbling, marinating and salting.

EASY OPERATION

- Automatic lid opening and closing system from GPA 200 model

FULL PROCESS CONTROL

- All process parameters are freely programmable via the MC2R control unit
- Most accurate temperature monitoring

VISUAL SAFETY DEVICE

- Sight glass for monitoring the vacuum unit

NUMEROUS COMBINATION POSSIBILITIES

- Rotating drum with automatic infinitely variable pivoting mechanism

DIFFERENT PRODUCT PROCESSING POSSIBILITIES

- Two directions of rotation for intensive and gentle tumbling or marinating

ENERGY-EFFICIENT COOLING TECHNOLOGY

4-layer drum insulation for a constant temperature level

	GPA 100	GPA 200	GPA 300	GPA 600
Drum volume in l	100	200	300	600
Filling degree in % (depending on product)	70	70	70	70
Dimensions in mm (length/width/height)	1000/1220/1400	2160/1730/2300	2250/1950/2300	2550/2120/2600
Connection values (standardised)	0.6 kW, 10 A, 230 V, 1 PH/N/PE	2.5 kW, 16 A, 400 V, 3 PH/N/PE	2.5 kW, 16 A, 400 V, 3 PH/N/PE	4 kW, 16 A, 400 V, 3 PH/N/PE

EXCELLENCE IN PROCESSING

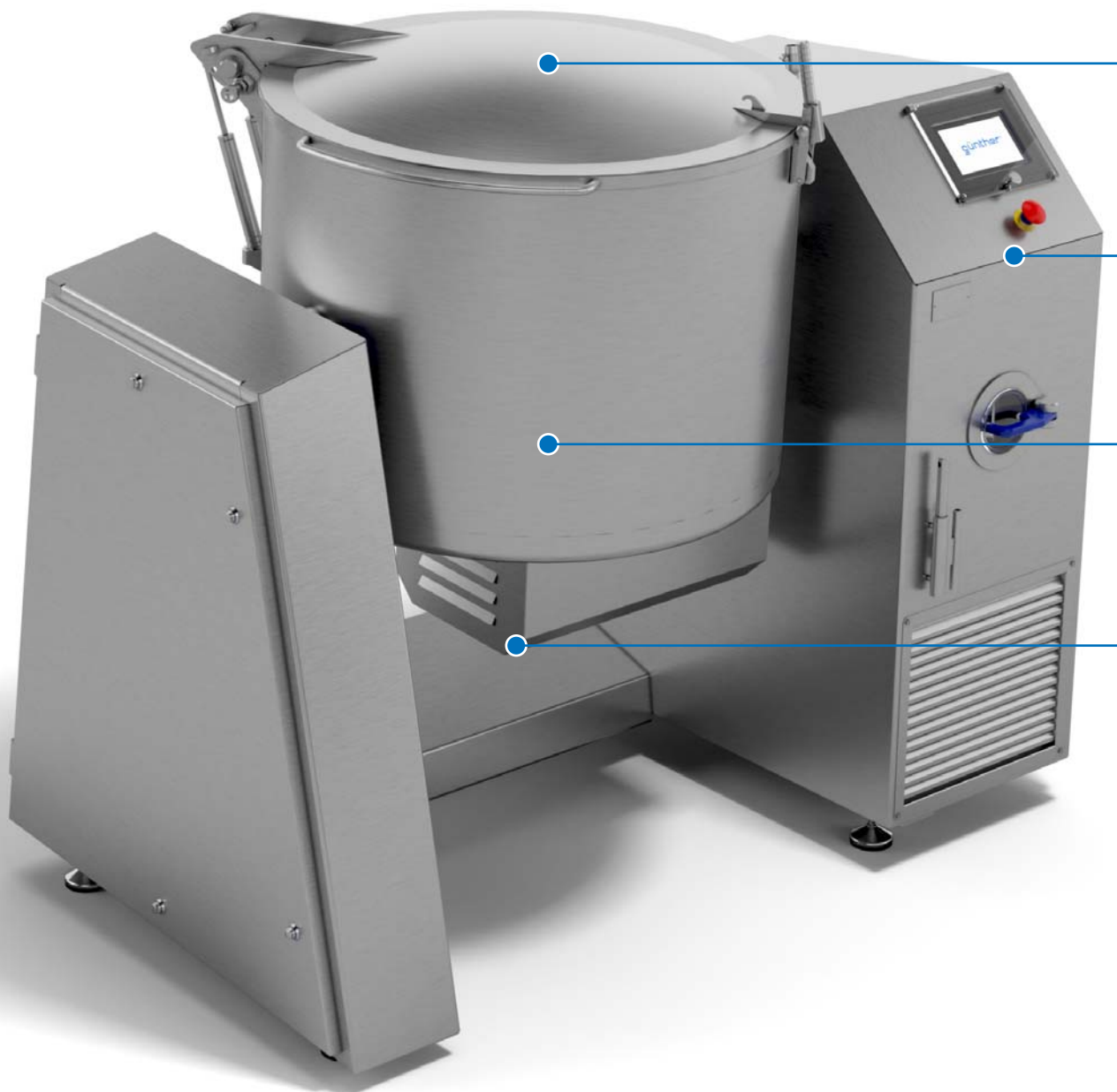

MORE INFORMATION?

Visit the section
on our website.

GPM MIXER

THE ALL-ROUNDER FOR MIXING AND MARINATING

GPM 100 – 600, the tilting tumbler with different mixer arms for small and medium-sized businesses. Perfect for marinating, mixing, salting.

EASY OPERATION

- Automatic lid opening and closing system from GPM 300 model

CONTROLLABLE VACUUM

- Integrated vacuum pump for interval or continuous vacuum

HIGH CAPACITY

- High loading of to 70% of the container volume

APPLICATION-SPECIFIC MIXING ARM

- Gentle or intensive, depending on product requirements

	GPM 100	GPM 200	GPM 300	GPM 600
Drum volume in l	100	200	300	600
Filling degree in % (depending on product)	70	70	70	70
Dimensions in mm (length/width/height)	1600/1320/2000	1800/1550/2340	2100/2050/2450	2400/2150/2850
Connection values (standardised)	1.5 kW, 10 A, 230 V, 1 PH/N/PE	3 kW, 16 A, 400 V, 3 PH/N/PE	3 kW, 16 A, 400 V, 3PH/N/PE	4.5 kW, 16 A, 400 V, 3PH/N/PE

EXCELLENCE IN PROCESSING

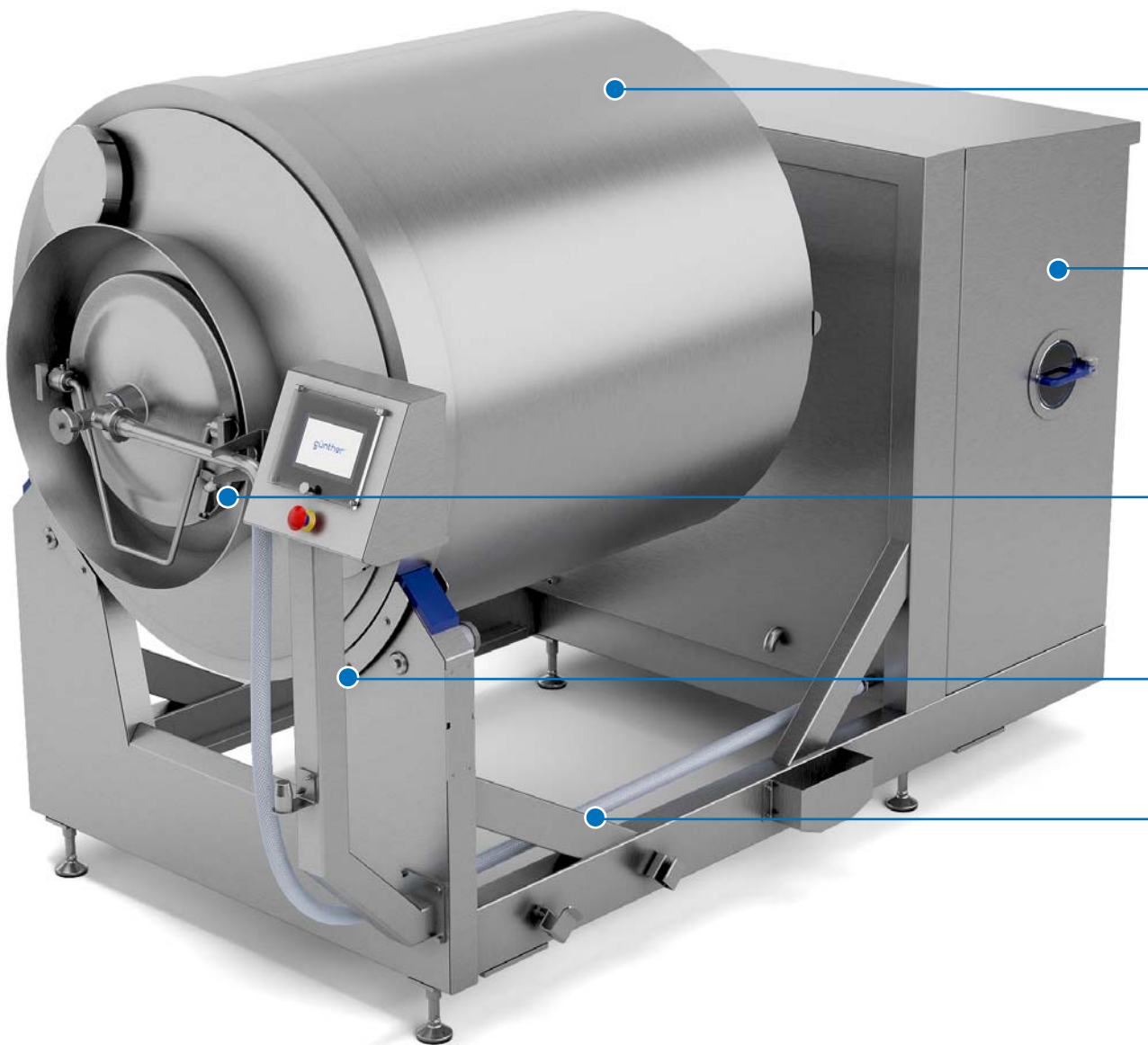

MORE INFORMATION?

Visit the section
on our website.

GPB TUMBLER

THE SPACE-SAVING HORIZONTAL TUMBLER FOR INDUSTRY

The space-saving industrial tumbler with high performance for a perfect end product of the highest quality

SOPHISTICATED BAFFLE TECHNOLOGY

- Asymmetrical baffles for better product processing and loading/unloading

VISUAL SAFETY DEVICE

- Sight glass for monitoring the vacuum unit

REDUCED MAINTENANCE

- Central lubrication of all essential components

ENERGY-EFFICIENT COOLING TECHNOLOGY

- 4-layer drum insulation for a constant temperature level

THE SPACE-SAVING VARIANT

- Perfectly suited for low ceiling

	GPB 1500	GPB 2200	GPB 4000	GPB 5500	GPB 7000	GPB 10000
Drum volume in l	1500	2200	4000	5500	7000	10000
Filling degree in % (depending on product)	55	55	55	55	55	55
Dimensions in mm (length/width/height)	2950/1710/2040	3000/2070/2140	3550/2070/2140	3950/2100/2330	4250/2200/2400	4750/2400/2600
Connection values (standardised)	4 kW, 16 A, 400 V, 3 PH/N/PE	5 kW, 32 A, 400 V, 3 PH/N/PE	5.5 kW, 32 A, 400 V, 3 PH/N/PE	9 kW, 32 A, 400 V, 3 PH/N/PE	19 kW, 63 A, 400 V, 3 PH/N/PE	24 kW, 63 A, 400 V, 3 PH/N/PE

EXCELLENCE IN PROCESSING

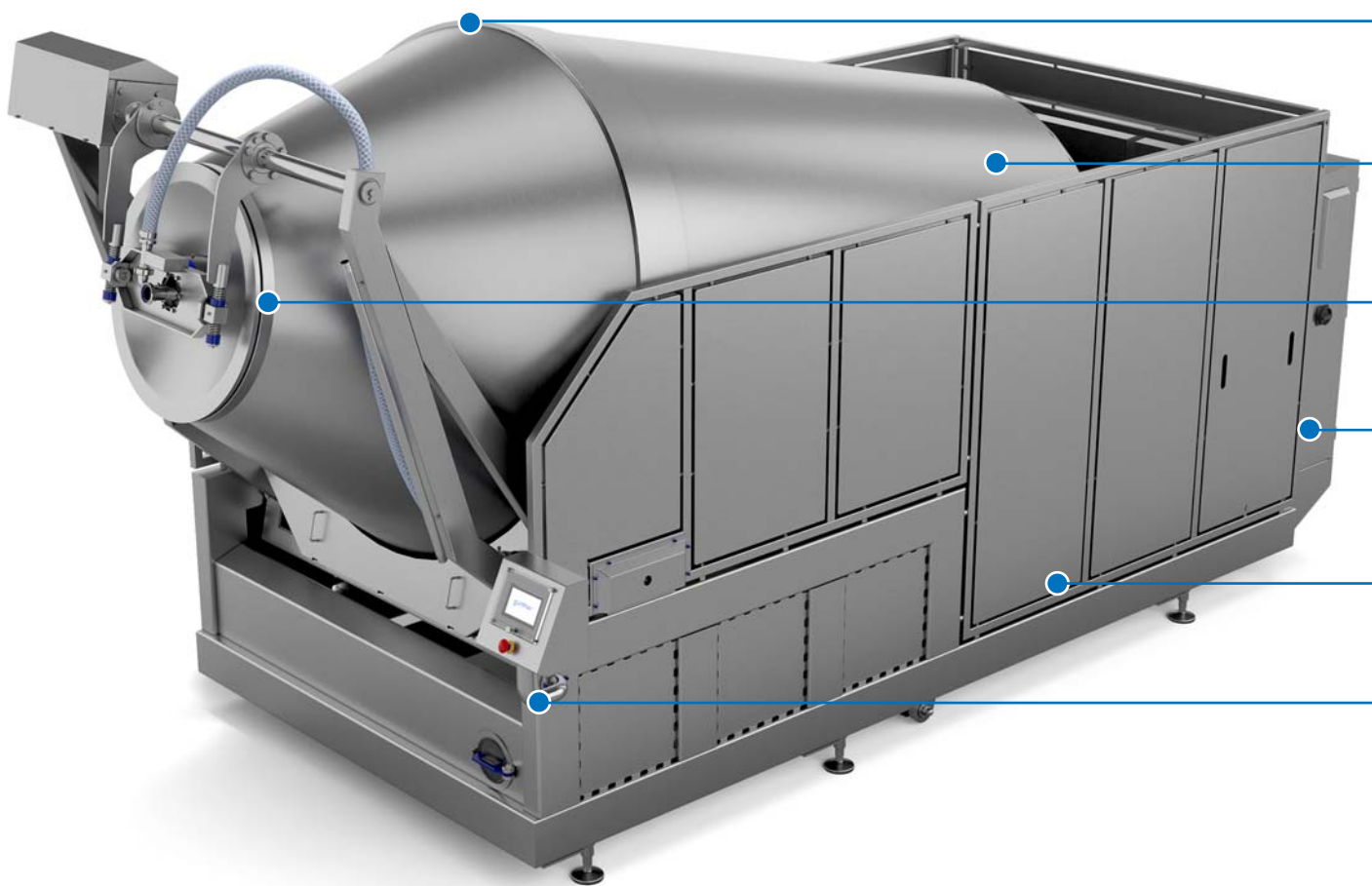

MORE INFORMATION?

Visit the section
on our website.

GPS TUMBLER

THE INDUSTRIAL, HIGHLY EFFICIENT SOLUTION FOR HIGH OUTPUTS

The tilting, compact, complete solution for industrial needs for even the highest requirements.

HIGHEST ACCURACY

- Weighing cells for batch monitoring – recording possible using Günther Pilot software

FASTER LOADING

- Larger product in-feed opening for optimised loading and unloading times

CONTINUOUS PRODUCT COOLING

- Cooled baffles until product discharge

EFFICIENT DRUM COOLING

- 4-layer drum structure for highly effective cooling

MAXIMUM PROTECTION OF SENSITIVE COMPONENTS

- Encapsulated construction: Box-in-box system

FULL PROCESS CONTROL

- All process parameters are freely programmable via the MC2R control unit
- Most accurate wireless temperature monitoring

	GPS 1250	GPS 2500	GPS 5000	GPS 7500	GPS 10000
Drum volume in l	1250	2500	5000	7500	10000
Filling degree in % (depending on product)	70	70	70	70	70
Dimensions in mm (length/width/height)	4350/1930/2600	5200/2120/3000	5880/2450/3600	6750/2600/3870	7500/2670/4300
Connection values (standardised)	5.5 kW, 32 A, 400 V, 3 PH/N/PE	7.5 kW, 63 A, 400 V, 3 PH/N/PE	11 kW, 63 A, 400 V, 3 PH/N/PE	19 kW, 63 A, 400 V, 3 PH/N/PE	24 kW, 63 A, 400 V, 3 PH/N/PE





EXCELLENCE IN PROCESSING •



MORE INFORMATION?

Visit the section
on our website.

BRINE PREPARATION

MIXING TANKS AND AUTOMATED BRINE TREATMENT PLANTS



EXCELLENCE IN PROCESSING



MORE INFORMATION?

Visit the section
on our website.

BRINE PREPARATION

MIXING TANKS AND AUTOMATED BRINE TREATMENT PLANTS

You have the perfect recipes for brine and sauces! We have the solutions for mixing, storing and cooling them. Günther mixing plants, brine treatment plants, tanks and coolers provide you with the perfect machinery for efficient and standardised work.

YOUR BENEFITS

- ⊕ Improved taste and flavour
- ⊕ Improved colour and colour retention
- ⊕ Improved slice cohesion
- ⊕ Time-saving, fast, controlled and efficient preparation of any type of brine, sauce or marinade
- ⊕ Prevention of segregation and deposition of brine constituents
- ⊕ Standardised, automated brine preparation



GLA 150–600

Efficient in mixing of liquids and brines

» from **p. 40**



GMA 400–2000

The all-rounder for making pickled and seasoned brines, marinades and sauces based on the suction flow principle

» from **p. 42**



GLT 400–2000

Storage tank for brine, marinades and sauces; includes agitator

» from **p. 44**



GRK 1–5

Heat exchanger for cooling brine and sauces in a continuous-flow process

» from **p. 46**

EXCELLENCE IN PROCESSING

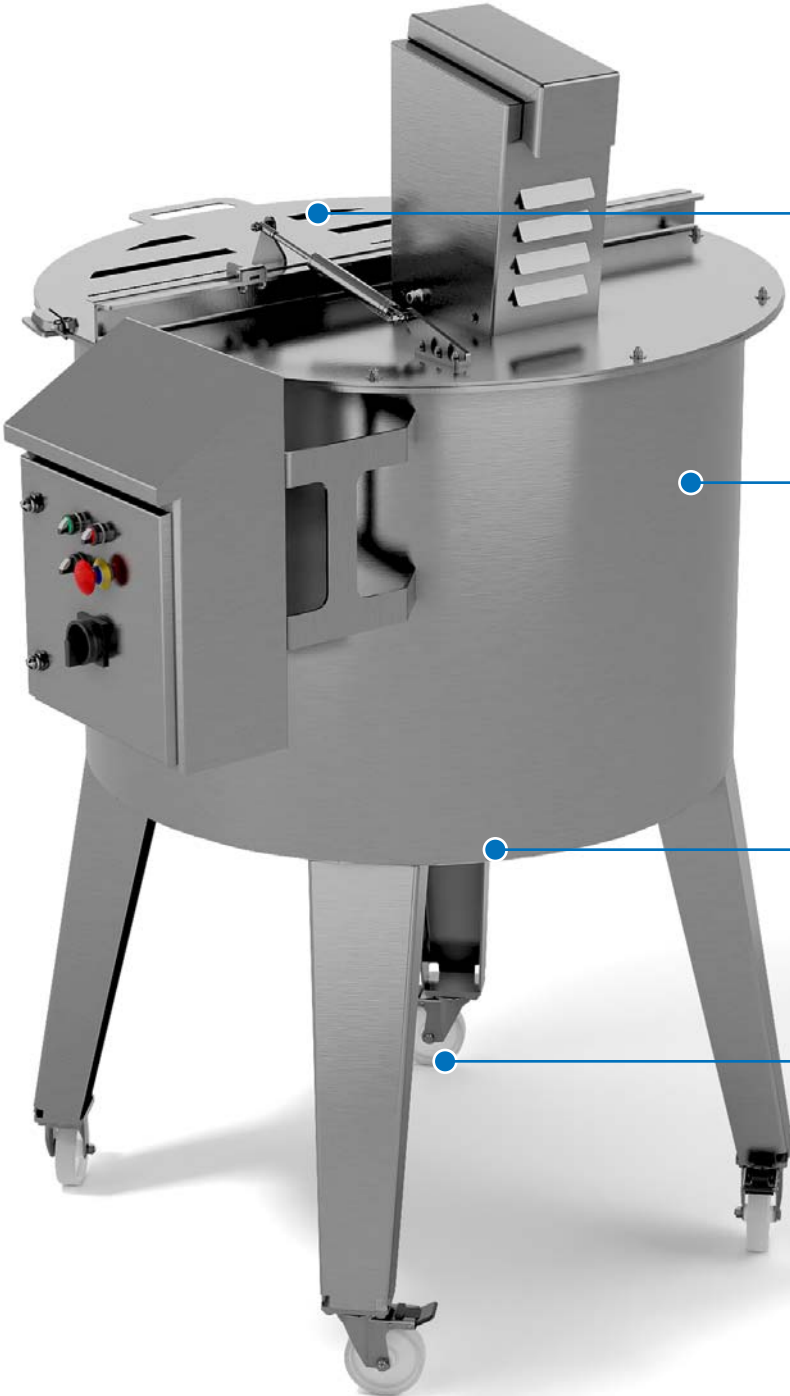

MORE INFORMATION?
Visit the section
on our website.

GLA

BRINE MIXER SYSTEM

The space-saving, mobile solution for the efficient preparation of brines and sauces.

VERSATILE EQUIPMENT

- For either liquid or solid additives

EASY-CARE DESIGN

- Easy to clean stainless steel frame

ECONOMICAL DESIGN

- Complete emptying via cylinder tank with rounded bottom and outlet pipe

PORTABLE AND HIGHLY EFFECTIVE

- Versatile and mobile

	GLA 150	GLA 300	GLA 600
Container volume in l	150	300	600
Dimensions in mm (length/width/height)	950/800/1730	1200/900/1850	1400/1370/2000
Connection values (standardised)	0.5 kW, 16 A, 400 V, 3 PH/N/PE	1.5 kW, 16 A, 400 V, 3 PH/N/PE	1.5 kW, 16 A, 400 V, 3 PH/N/PE

EXCELLENCE IN PROCESSING



MORE INFORMATION?

Visit the section
on our website.

GMA

MIXING PLANT

Compact Günther mixing plant with funnel for supply of solids. For standardised, efficient and automated mixing of pickled, seasoned brines, marinades and sauces.

STANDARD TURBO MIXER

- For mixing solid additives, such as flaked ice

TRIED AND TESTED SUCTION FLOW TECHNOLOGY

- Quick and easy mixing of liquids of different viscosities as well as powdered additives

FULLY AUTOMATED COMPLETE SOLUTION

- For memorizing the tank contents via an intuitive MC2R touchscreen control unit with recipe storage function

HIGHLY HYGIENIC DESIGN

- CIP cleaning jets for easy cleaning of inner container surfaces

	GMA 400	GMA 750	GMA 1000	GMA 1500	GMA 2000
Container volume in l	400	750	1000	1500	2000
Dimensions in mm (length/width/height)	1670/1000/2000	1850/1300/2400	1950/1300/2900	2700/1660/2640	2900/1660/2900
Connection values (standardised)	3.7 kW, 16 A, 400 V, 3 PH/N/PE	5.5 kW, 16 A, 400 V, 3 PH/N/PE	5.5 kW, 16 A, 400 V, 3 PH/N/PE	5.5 kW, 16 A, 400 V, 3 PH/N/PE	5.5 kW, 16 A, 400 V, 3 PH/N/PE
Compressed air	6–8 bar	6–8 bar	6–8 bar	6–8 bar	6–8 bar
Water	DN 32	DN 32	DN 32	DN 32	DN 32

EXCELLENCE IN PROCESSING



MORE INFORMATION?

Visit the section
on our website.

GLT

STORAGE CONTAINER FOR BRINE, MARINADES AND SAUCES

For storing large quantities of brine, marinades and sauces. The Günther brine tank is the perfect addition to complete the Günther brine preparation systems. A cooled jacket shell prevents the brine from warming up. The integrated agitator ensures that solid constituents do not settle on the bottom of the tank.

STANDARDISED BRINE STORAGE

- Tank lid with integrated agitator

INTUITIVE CONTROL UNIT

- Easy operation through direct command input

CONCISE FILLING LEVEL MONITORING

- Visual indication of the fill level

EMPTYING ON DEMAND

- Superordinate control unit to start the emptying process via pneumatic valve control

	GLT 400	GLT 750	GLT 1000	GLT 1500	GLT 2000
Container volume in l	400	750	1000	1500	2000
Dimensions in mm (length/width/height)	1200/1000/2000	1480/1300/2400	1480/1300/2900	2240/1660/2640	2330/1660/2900
Connection values (standardised)	4 kW, 16 A, 400 V, 3 PH/N/PE	4 kW, 16 A, 400 V, 3 PH/N/PE	4 kW, 16 A, 400 V, 3 PH/N/PE	4 kW, 16 A, 400 V, 3 PH/N/PE	4 kW, 16 A, 400 V, 3 PH/N/PE
Compressed air	6–8 bar	6–8 bar	6–8 bar	6–8 bar	6–8 bar
Water	DN 32	DN 32	DN 32	DN 32	DN 32

EXCELLENCE IN PROCESSING

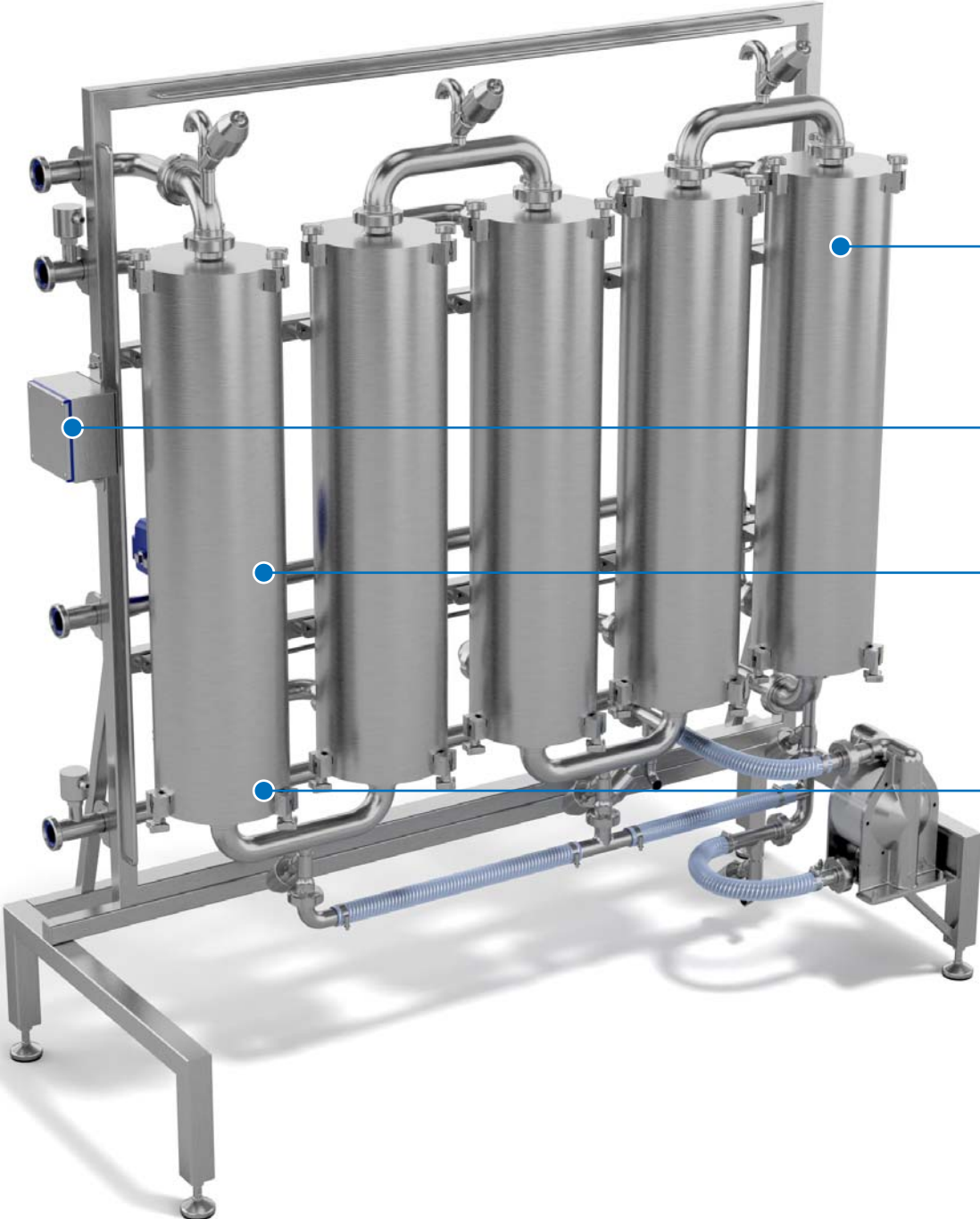

MORE INFORMATION?

Visit the section on our website.

GRK

PIPE COOLER FOR COOLING BRINE AND SAUCES IN A CONTINUOUS PROCESS

Unplanned downtime due to heated brine is a thing of the past with the Günther pipe cooler system. In the integrated system and in-line process, Günther pipe coolers ensure consistent cooling of brines and sauces, even with large production volumes.

FOODSTUFF-COMPLIANT STRUCTURE

- Easy to clean thanks to the stainless steel construction

STAND-ALONE OPERATION

- Integrated control unit

EVEN COOLING

- Counterflow-based shell and tube heat exchangers

MONITORING AND TRACEABILITY

- Temperature regulator with temperature sensors

	GRK 1	GRK 2	GRK 3	GRK 4	GRK 5
Cooling capacity in kW	5	10	15	20	25
Dimensions in mm (length/width/height)	700/700/1600	1250/1000/2200	1400/1000/2200	1700/1000/2200	1690/820/1950
Connection values (standardised)	2.2 kW, 16 A, 400 V, 3 PH/N/PE	2.2 kW, 16 A, 400 V, 3 PH/N/PE	2.2 kW, 16 A, 400 V, 3 PH/N/PE	2.2 kW, 16 A, 400 V, 3 PH/N/PE	2.5 kW, 16 A, 400 V, 3 PH/N/PE
Compressed air	6–8 bar	6–8 bar	6–8 bar	6–8 bar	6–8 bar





EXCELLENCE IN PROCESSING •





ROLLER AND KNIFE STEAKERS

**FOR THE REFINEMENT OF YOUR PRODUCT AND PREPARATION
FOR FURTHER PROCESSING**



EXCELLENCE IN PROCESSING



MORE INFORMATION?

Visit the section
on our website.

ROLLER AND KNIFE STEAKERS

FOR THE REFINEMENT OF YOUR PRODUCT AND PREPARATION FOR FURTHER PROCESSING

Improve the quality of your products by refining them with a Günther roller or knife steaker. Optimise your products by eliminating brine nests and bringing out their tenderness

YOUR BENEFITS

- ⊕ Tenderness, better mouth feel
- ⊕ Shorter tumbling times due to better protein breakdown
- ⊕ Improved slice cohesion, less giveaway
- ⊕ Standardisation of your products
- ⊕ Better colour retention
- ⊕ Larger product surface



GTK KNIFE STEAKER

The Günther Knife Steaker is characterised by its robustness and efficiency. Available as an additional module in the Günther injectors or as a stand-alone machine. Adapted to suit your circumstances with different belt widths and number of knives.

» from **p. 52**



GTR ROLLER STEAKER

The Günther Roller Steaker impresses with its high performance and flexibility, as a line solution or a stand-alone machine. Different knife rollers refine your product in preparation for further production processing. The machine is available in different belt widths and is astonishingly space-saving.

» from **p. 54**

EXCELLENCE IN PROCESSING



MORE INFORMATION?

Visit the section
on our website.

KNIFE STEAKER

As an integrated solution or a stand-alone system, the GTK is the perfect complement to your product finishing process. Perfect surface treatment through vertical knife movement, just like the proven Günther injector drive technology.

PRECISE CUT

- Cutting depth adjustment by effective servo drive

PERFECT EQUIPMENT

- Special stainless steel knives available in different versions

DESIRED PRODUCT RESULT

- Different cutting patterns possible
- Multiple or single cut
- Variably adjustable

PRECISE MACHINING

- Precise product positioning and knife guidance through blank-holder technology

	GTK 365-75	GTK 480-124	GTK 605-156	GTK 605-258
Belt width in mm	365	480	605	605
Number of knives	75	124	156	258
Cutting depth	up to 1 mm over the belt	up to 1 mm over the belt	up to 1 mm over the belt	up to 1 mm over the belt
Dimensions in mm (length/width/height)	1800/1000/2500	2330/1270/2740	2610/1400/2740	2610/1400/2740
Connection values (standardised)	2 kW, 16 A, 400 V, 3 PH/N/PE	8 kW, 32 A, 400 V, 3 PH/N/PE	8 kW, 32 A, 400 V, 3 PH/N/PE	8 kW, 32 A, 400 V, 3 PH/N/PE



EXCELLENCE IN PROCESSING

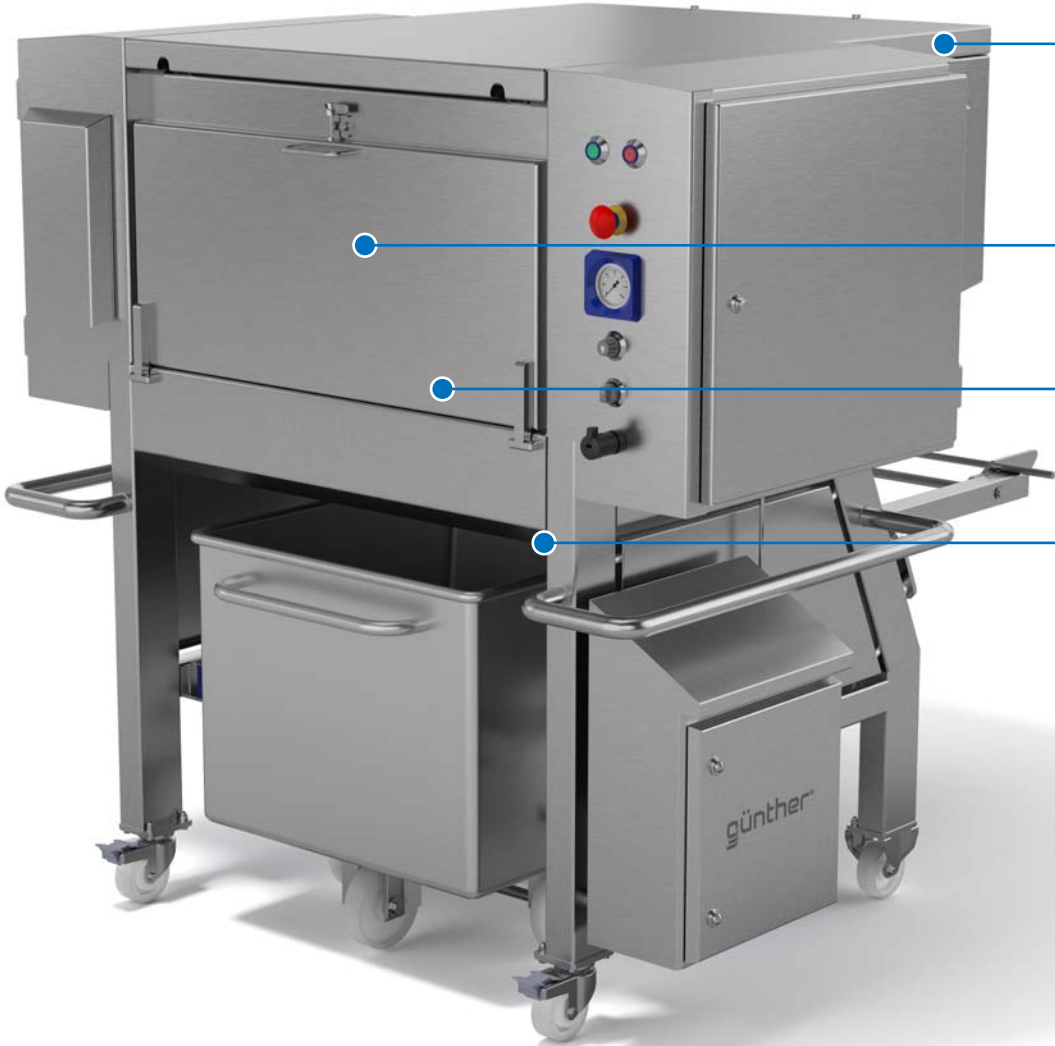

MORE INFORMATION?
Visit the section
on our website.

GTR

ROLLER STEAKER

Rotating knives ensure resounding product refinement in a continuous process. The Günther Roller Steaker is ideally suited to high product capacities. Different belt widths allow easy line integration.

COMPACT HIGH PERFORMER

- Robust and compact design, made completely of stainless steel as well as high-quality and food-safe plastics

PATENTED STEAKER SHAFT SUSPENSION

- Tool-free and easy disassembly of rollers and belts for cleaning

PNEUMATIC PRODUCT ADAPTATION

- The upper knife roller automatically adapts to the thickness of the product

CONTINUITY GUARANTEE

- High production capacities through uninterrupted product transport

	GTR 365-64	GTR 480-84	GTR 605-92
Belt width in mm	365	480	605
Number of knives	64	84	92
Cutting depth	depending on knife size	depending on knife size	depending on knife size
Dimensions in mm (length/width/height)	1250/1280/1440	1700/1400/1500	2030/1600/1630
Connection values (standardised)	1 kW, 16 A, 400 V, 3 PH/N/PE	2.5 kW, 16 A, 400 V, 3 PH/N/PE	2.5 kW, 16 A, 400 V, 3 PH/N/PE
Compressed air	6–8 bar	6–8 bar	6–8 bar



EXCELLENCE IN PROCESSING •





GÜNTHER COATING TECHNOLOGY

REFINING AND FREEZING OF PRODUCTS WITH SAUCES,
SPICES AND MARINADES



EXCELLENCE IN PROCESSING



MORE INFORMATION?

Visit the section on our website.

REFINING OF PRODUCTS WITH SAUCES, SPICES AND MARINADES

Your customers appreciate high quality and low effort when preparing food. The Günther coating technology provides support, particularly when it comes to the production of ready-meals, because perfected coating systems are one of our core competences. Coat your products with spices, sauces or marinades in combination with subsequent shock freezing.

YOUR BENEFITS

- ⊕ 0% sauce residue
- ⊕ Time saving thanks to the use of thermal lances as standard
- ⊕ Perfect coating of viscous sauces
- ⊕ Food of the highest quality
- ⊕ 6 times less food waste
- ⊕ Safe transportation of sensitive foods
- ⊕ Longer shelf life
- ⊕ Reproducible taste experience



GPC 600-12000

For natural flavour enhancement

» from **p. 60**

EXCELLENCE IN PROCESSING

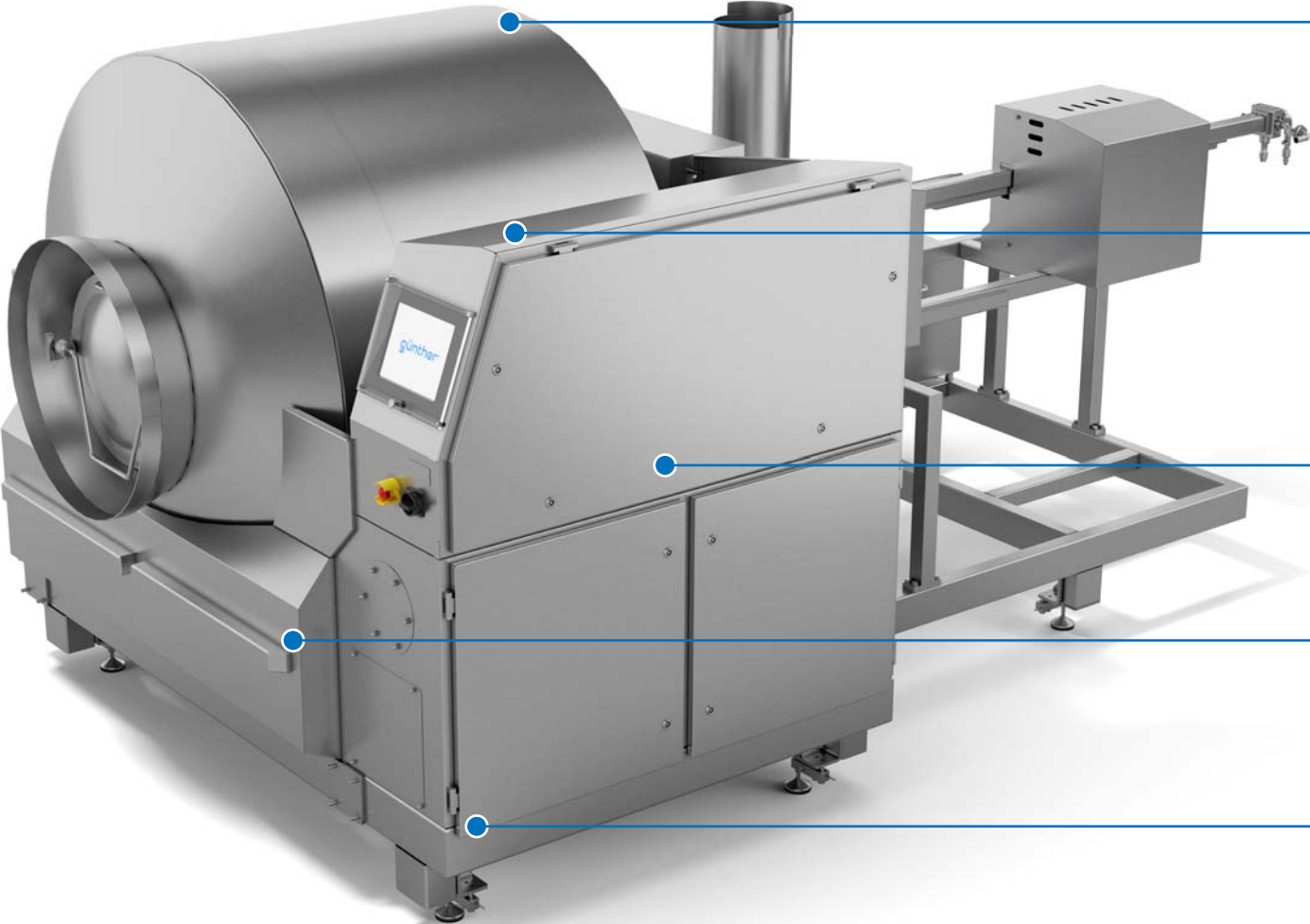

MORE INFORMATION?

Visit the section on our website.

GPC

GÜNTHER COATING TECHNOLOGY

Are you keen on manufacturing your products in a considerate and reliable way? Take advantage of the unique Günther Coating technology with integrated shock freeze function.

PERFECT CLEANING

- Flow-jet nozzles and optimally movable lances for perfect cleaning of stainless steel surfaces

TRIED AND TESTED COATING LANCE TECHNOLOGY

- Various thermal lances with quick-change nozzle system

CONTROLLABLE SPRAY PATTERN

- Precise adjustment of the nitrogen and sauce flow rate

INDIVIDUAL CHARGING VERSIONS

- Belts, screw conveyors, funnels to suit your application

PLANT TECHNOLOGY FROM ONE SOURCE

- Günther Product Line Solutions

	GPC 600	GPC 2200	GPC 4000	GPC 7000	GPC 12000
Drum volumes	600	2200	4000	7000	12000
Filling degree in % (depending on product)	50	50	50	50	50
Dimensions in mm (length/width/height)	4000/2000/1900	6000/2500/2170	7000/2500/2800	9400/3000/2900	12000/3500/3200
Connection values (standardised)	4 kW, 16 A, 400 V, 3 PH/N/PE	5.5 kW, 32 A, 380 V, 3 PH/N/PE	7 kW, 32 A, 400 V, 3 PH/N/PE	8.5 kW, 32 A, 400 V, 3 PH/N/PE	17 kW, 63 A, 400 V, 3 PH/N/PE





EXCELLENCE IN PROCESSING •

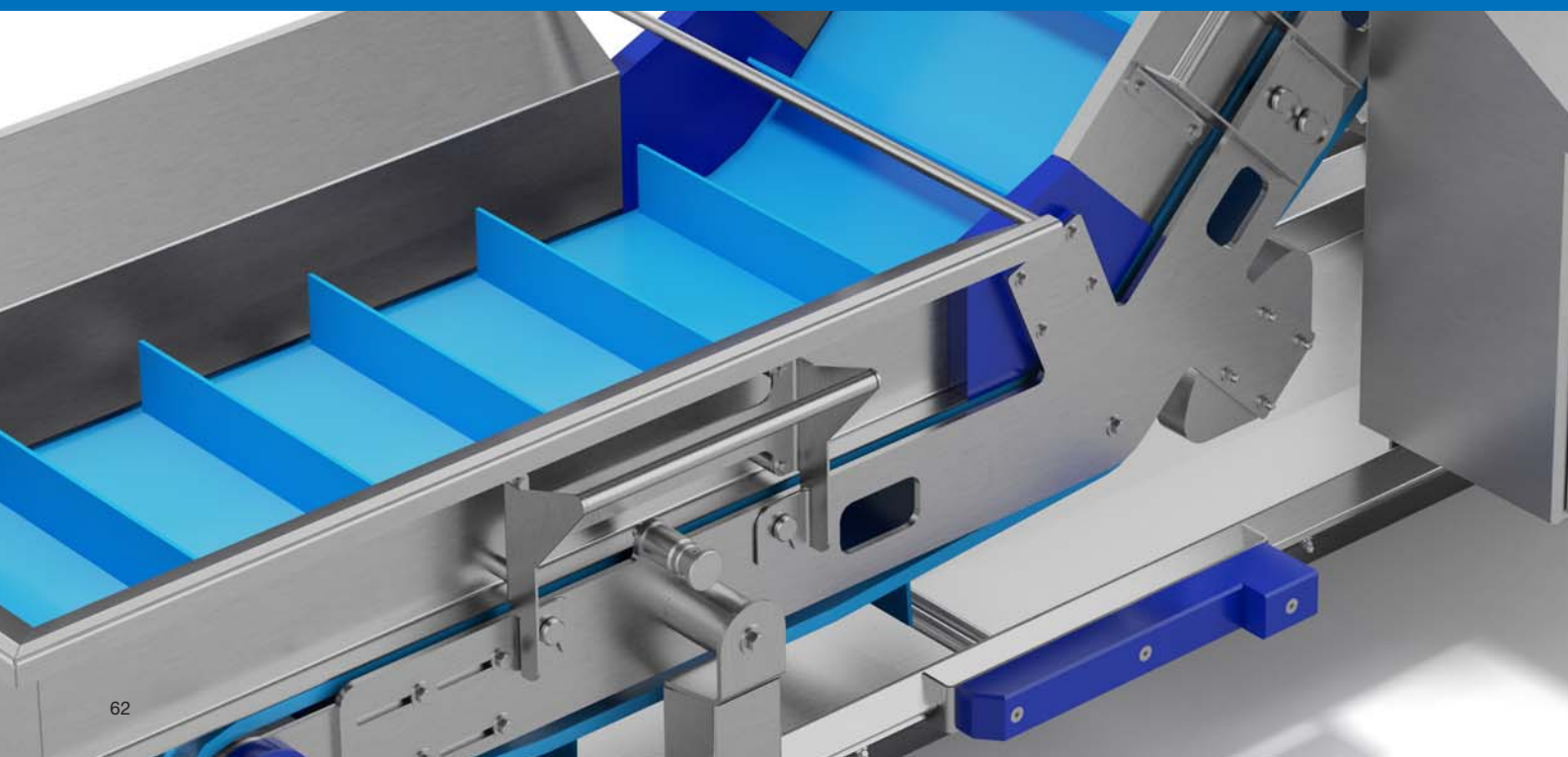

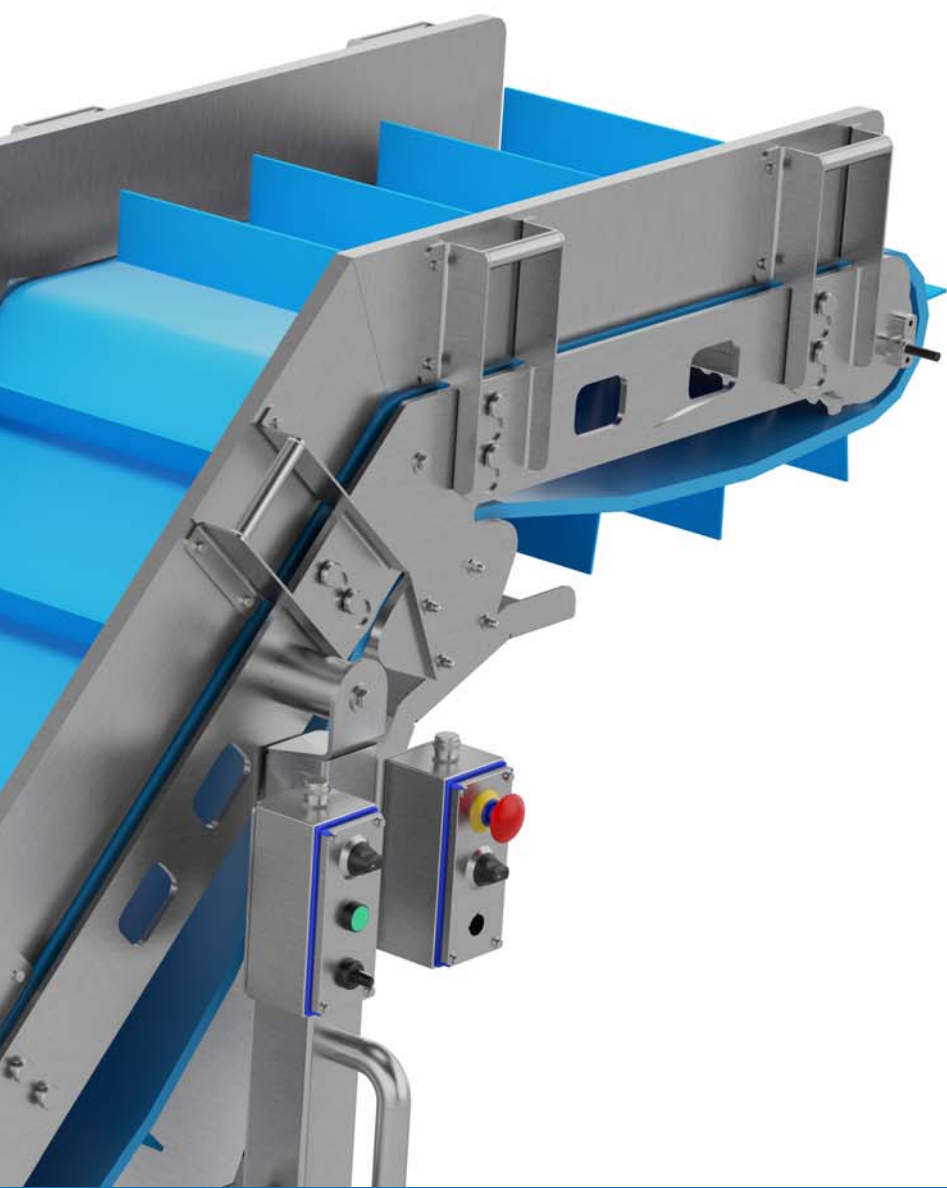

PERIPHERIES

AUTOMATED SOLUTIONS FOR PRODUCT HANDLING AND LINE OPERATION



EXCELLENCE IN PROCESSING

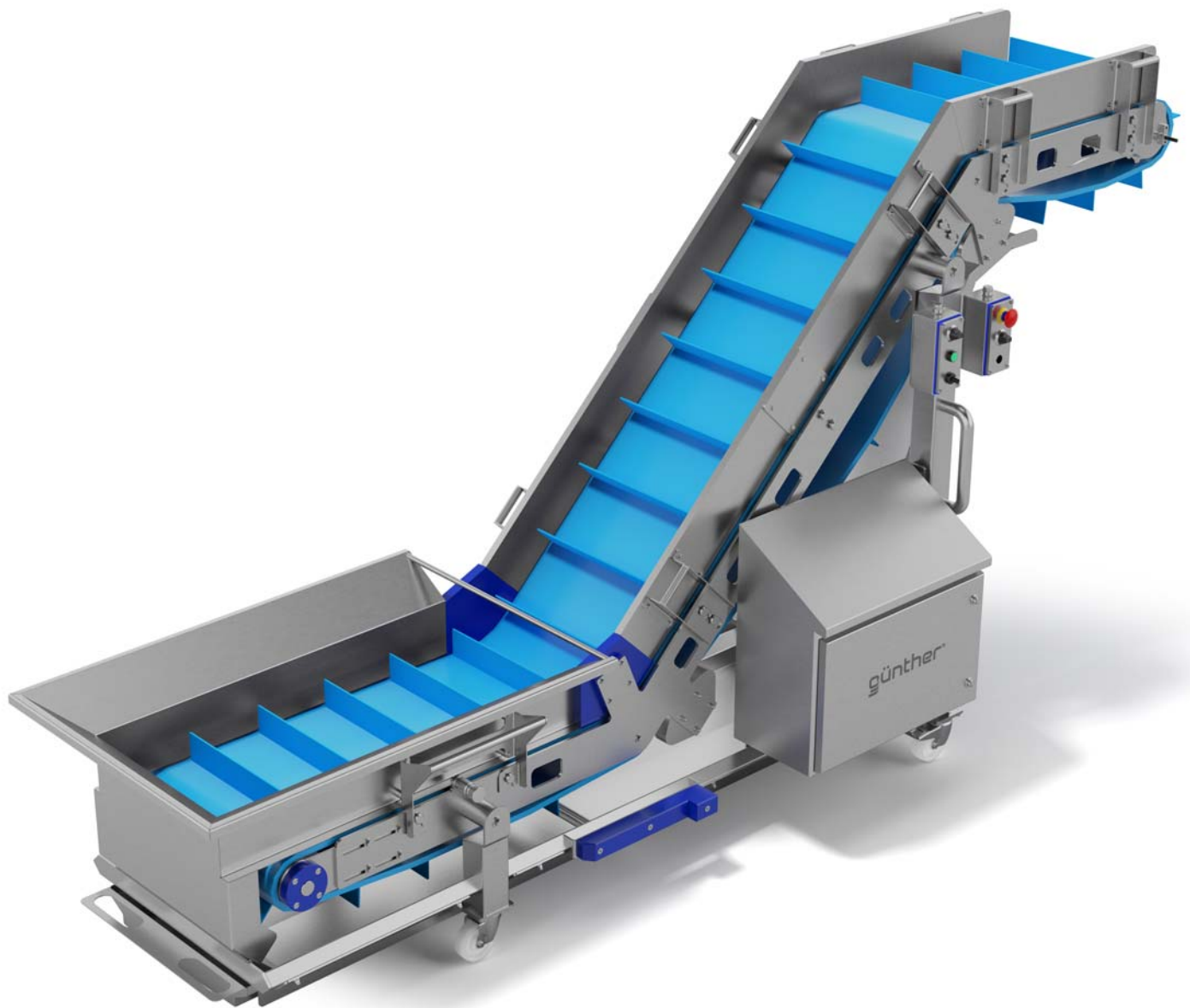

MORE INFORMATION?

Visit the section
on our website.

PERIPHERIES

AUTOMATED SOLUTIONS FOR PRODUCT HANDLING AND LINE OPERATION

In addition to our powerful core machines, we offer you the perfect additions for line operation or machine expansion. With standardised feeders, vacuum or lifting and tipping jigs, you can quickly start up line operation. Alternatively, you can optimise your current machine inventory individually.

YOUR BENEFITS

- ⊕ Simple interface transfers
- ⊕ Rapid connection of the machinery to each other
- ⊕ Automated solutions for your line operation
- ⊕ As a stand-alone solution
- ⊕ Perfect supplement for your existing machinery inventory
- ⊕ Customised solutions possible at any time



GHK

The Günther lifting and tipping jig for 200 L standard trolleys in accordance with DIN 9797 and Big Boxes.

GSH 200

The space-saving solution loader for 200 L standard trolleys in accordance with DIN 9797.

GZB 365–605

Solid high-hygiene belts support you in continuous or clocked transport of your products.

GVB 1000–7000

Fully automated vacuum loaders for residue-free transport.

GSB 350–900

Perfect belt solution for bridging larger height differences. Optionally in combination with carriers for bulk product applications.

» from **p. 66**

» from **p. 68**

» from **p. 70**

» from **p. 72**

» from **p. 74**

EXCELLENCE IN PROCESSING

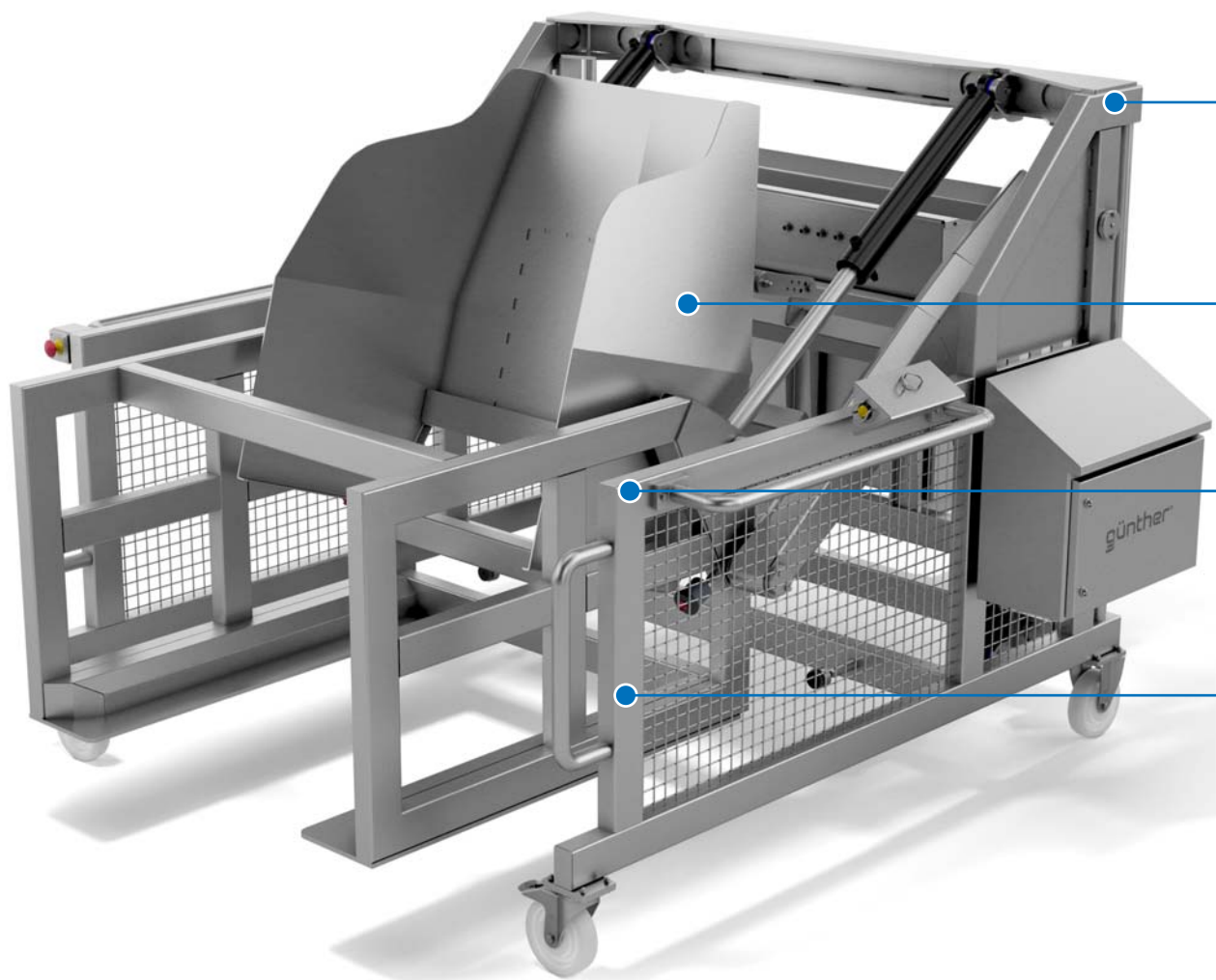

MORE INFORMATION?

Visit the section
on our website.

LIFTING AND TIPPING JIG

Robust and safe design for emptying standard trolleys and Big Boxes. Proven hydraulic technology ensures reliable lifting of containers.

MOST STABLE CONSTRUCTION

- Foodstuff-compliant and latest safety-engineered construction
- Lifting fork with two lifting cylinders made of stainless steel

PERFECT PRODUCT GUIDANCE

- Integrated feed hopper for gentle and safe loading

SOPHISTICATED USER SAFETY

- State-of-the-art operator protection thanks to two-handed operation

FLEXIBLE MOVEMENT OPTIONS

- Mobile on customer request on wheels or rails

	GHK 200	GHK 600/800	GHK 1000
Suitable for	200 L standard trolleys	Big Boxes	Big Boxes
Maximum lifting load in kg	250	600–800	600–800
Dimensions in mm (length/width/height)	1800/1570/2870	2900/3150/3900	2000/2050/3000
Connection values (standardised)	3 kW, 16 A, 400 V, 3 PH/N/PE	7.5 kW, 16 A, 400 V, 3 PH/N/PE	1.5 kW, 16 A, 400 V, 3 PH/N/PE



EXCELLENCE IN PROCESSING



MORE INFORMATION?
Visit the section
on our website.

GSH 200

COLUMN LOADER

Fixed to the floor or mobile version. The perfect solution for loading using standard DIN 9797 trolleys.

EASY-CARE DESIGN

- Moulded stainless steel body

USER-FRIENDLY CONTROL UNIT

- Intuitive push-button control unit

PERFECT PRODUCT GUIDANCE

- Integrated feed hopper for gentle and safe loading

MINIMAL INSTALLATION SPACE

- Space-saving alternative by being firmly fixed to the floor

	GSH 200
Suitable for	200 L standard trolleys
Maximum lifting load in kg	250
Dimensions in mm (length/width/height)	2000/1930/2650
Connection values (standardised)	1.5 kW, 16 A, 400 V, 3 PH/N/PE

EXCELLENCE IN PROCESSING

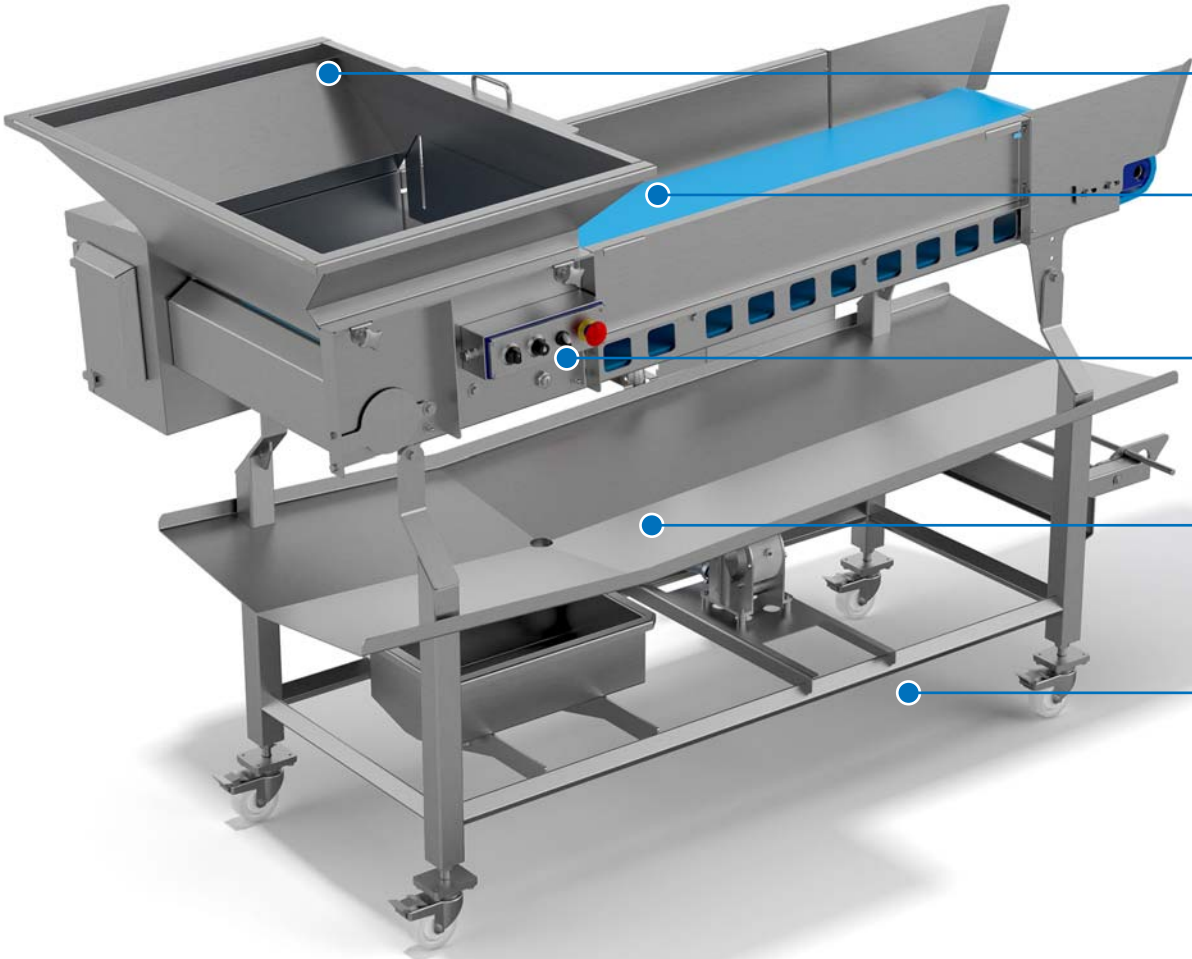

MORE INFORMATION?

Visit the section on our website.

GZB 365 – 605

INDUCTION BELT

The automatic solution for feeding your machines. Induction belts in different variants with or without loading hopper.

OPTIMISED LOADING FUNCTION

- Superordinate control unit to regulate the individual speed

INDIVIDUAL DESIGN OPTIONS

- Variable belt lengths and inclination angles

FLEXIBLE APPLICATION

- Conveyor option in cycle or continuous operation

REDUCED BRINE WASTE

- Integrated brine recirculation into the filter system

HYGIENIC CONSTRUCTION

- Moulded stainless steel body
- Foodstuff-compliant construction for easy cleaning

	GZB 365	GZB 480	GZB 605
Belt width in mm	365	480	605
Dimensions in mm (length/width/height)	2900/1000/1300	3000/1120/1430	3150/1250/1580
Connection values (standardised)	1 kW, 16 A, 400 V, 3 PH/N/PE	1 kW, 16 A, 400 V, 3 PH/N/PE	2 kW, 16 A, 400 V, 3 PH/N/PE

EXCELLENCE IN PROCESSING

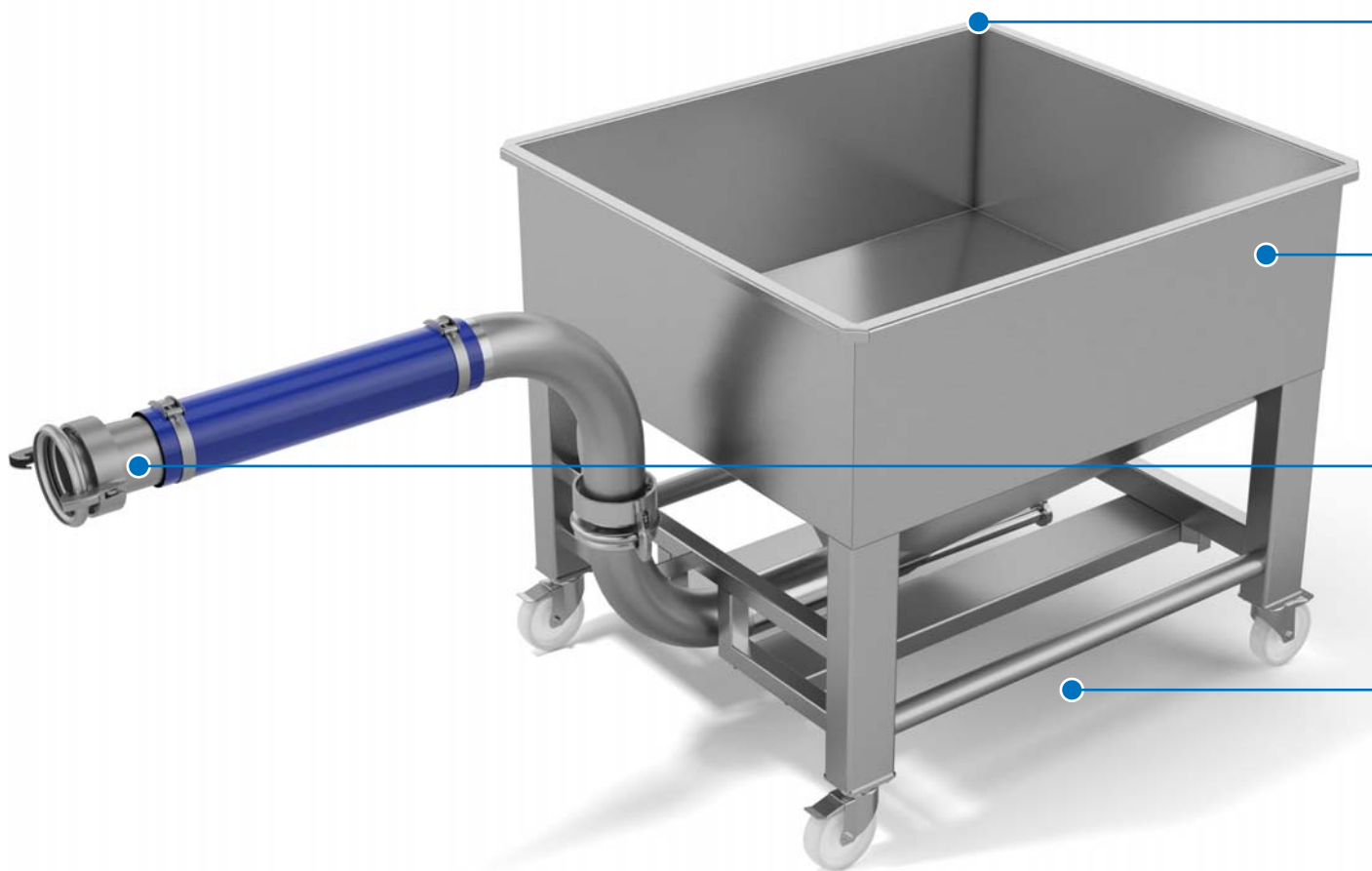

MORE INFORMATION?

Visit the section
on our website.

GVB 1000–7000

VACUUM LOADING

Buffer tank for loading machines under vacuum.

OPTIMUM PROCESS CONTROL

- On request with weighing cells to control filling of the vacuum hopper and the following machine

DIFFERENT OPENING MECHANISMS

- Automatic flat slide valve or manual ball valve

EASY LOADING

- DN 150 connection for easy filling of machines under vacuum

EASY-CARE DESIGN

- Foodstuff-compliant construction for easy cleaning

	GVB 1000	GVB 2000	GVB 3000	GVB 5000	GVB 7000
Container volume in l	1000	2000	3000	5000	7000
Dimensions in mm (length/width/height)	2000/1300/1220	2320/1400/1220	2470/2100/1220	2700/2400/1700	3100/2800/1900

EXCELLENCE IN PROCESSING

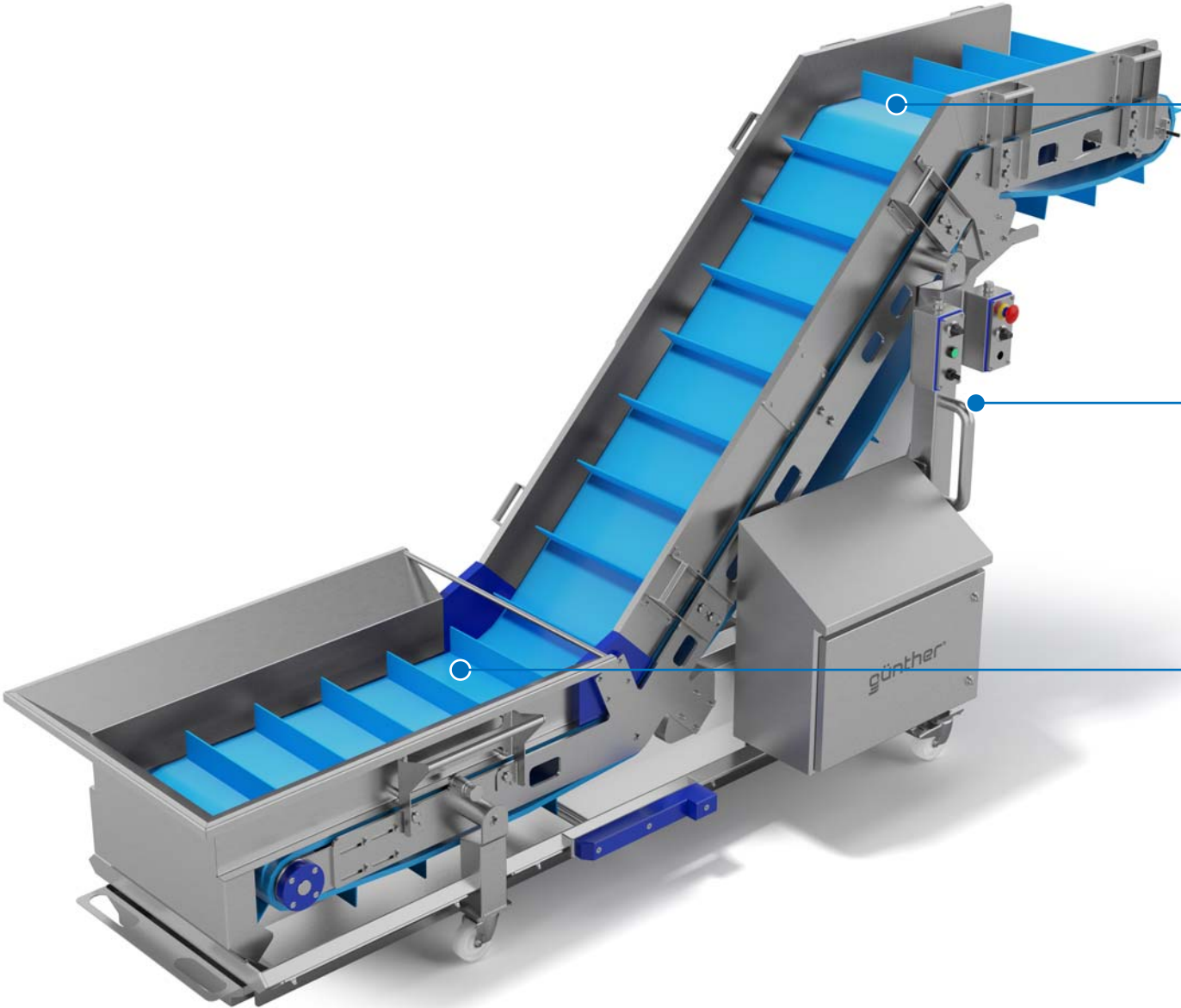

MORE INFORMATION?

Visit the section on our website.

GSB 350–900

ASCENDING BELT CONVEYORS

Ideal for transporting bulk materials. Thanks to its design ideally suited for bridging height differences. The optimal solution for automating the interface to the next production process.

PRODUCT-ADAPTED CARRIERS

- The right carrier height for every application

ROBUST CONSTRUCTION

- Durable stainless steel construction for your business success

CONTROLLED LOADING

- Optimum loading of the belt with angled product guidance

	GSB 480	GSB 480	GSB 605
Belt width in mm	365	480	605
Dimensions in mm (length/width/height)	3240/1015/1780	3240/1115/1780	3240/1250/1780
Connection values (standardised)	3 kW, 16 A, 400 V, 3 PH/N/PE	3 kW, 16 A, 400 V, 3 PH/N/PE	3 kW, 16 A, 400 V, 3 PH/N/PE
Compressed air	6 bar, 5–10 l (brine pump)	6 bar, 5–10 l (brine pump)	6 bar, 5–10 l (brine pump)



EXCELLENCE IN PROCESSING •





günther®

TECHNOLOGY, SOFTWARE, HYGIENE

CROSS-APPLICATION TECHNOLOGY ENHANCEMENT



SOFTWARE

GÜNTHER PILOT

Traceability, documentation and transparency of all processes are among the biggest challenges in the food industry. System integration and consolidation of different manufacturers, machine models and data present you with new challenges every day.

Our solution to your challenges: Günther Pilot provides you with status messages; in the event of process deviations, the responsible personnel is automatically informed by e-mail or SMS. Error messages are displayed immediately.

YOUR BENEFITS

- ⊕ Receipt of production orders
- ⊕ Breakdown and distribution of data to the machines required for the process
- ⊕ Integration of external peripherals
- ⊕ Recording of all recipe and process data
- ⊕ Visualisation of the data
- ⊕ Message output in the event of process deviations and provision of all data for superordinate systems
- ⊕ Completion of documentation through data backup and recovery

QUALITY ASSURANCE AND PROCESS OPTIMISATION WITH GÜNTHER PILOT SOFTWARE

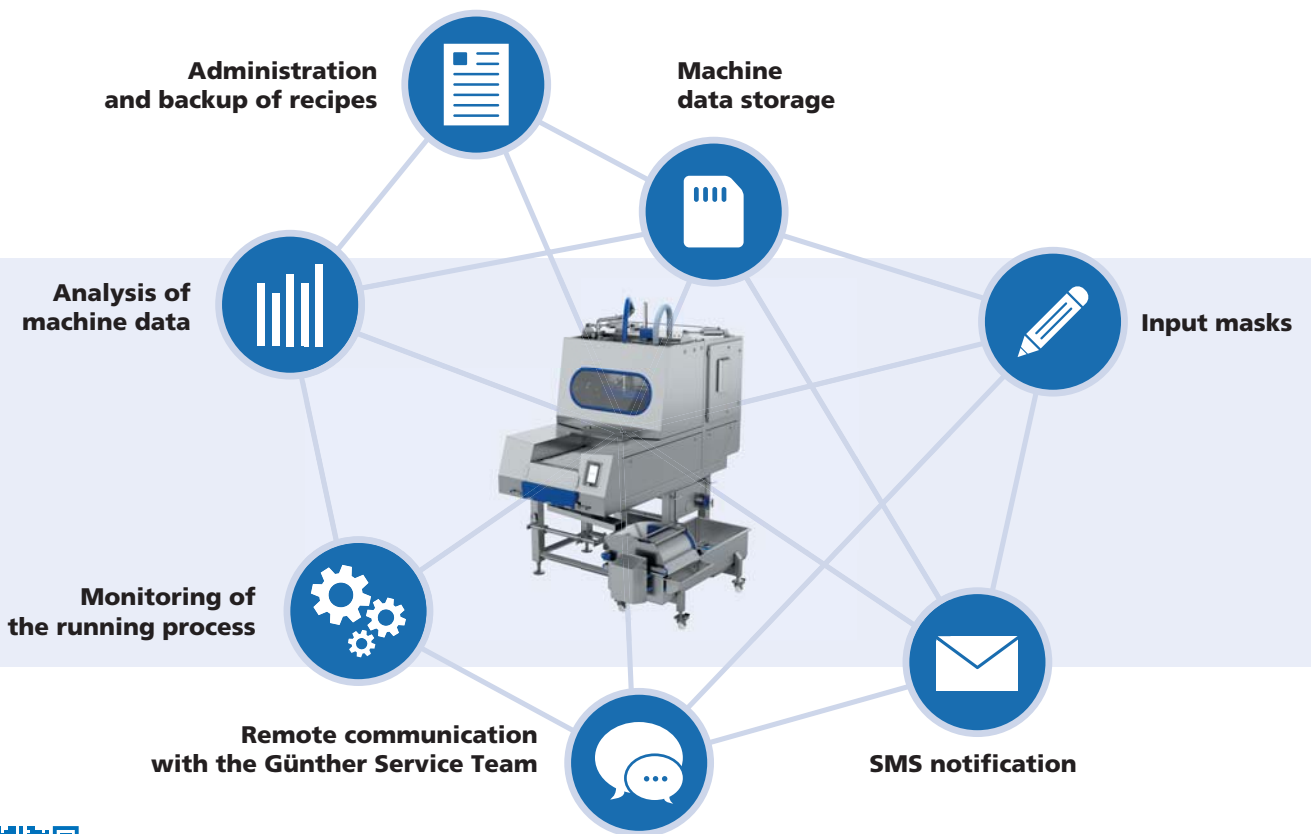

MORE INFORMATION?

Visit the section on our website.

GÜNTHER THAWING TECHNOLOGY

Defrosting deep-frozen products for further processing in the shortest possible time is one of our core competencies. Fluctuating demand requires flexibility and short reaction times. High stock levels of frozen raw materials are a thing of the past with Günther thawing technology. The combination of direct and indirect heat transfer, vacuum and fully tempered baffles ensures optimum product results.

YOUR BENEFITS

- ⊕ Gentle product defrosting process thanks to controlled heat input
- ⊕ Reproducible thawing results
- ⊕ Increased yield – no drip loss
- ⊕ Higher efficiency compared to standard defrosting processes

ACCELERATION OF THAWING PROCESS WITHOUT LOSS OF QUALITY



40 % time reduction thanks to Günther thawing technology



Frozen product



Brine



Thawed, finished product

MORE INFORMATION?

Visit the section on our website.



EXCELLENCE IN PROCESSING



NEEDLE HEAD CLEANING STATION

Hygiene, high availability and short set-up times are the hallmarks of our injectors. The core of the injector is the needle head with a large number of individual needles. In order to always stand out from the crowd with the quality of your products, we recommend regular intensive cleaning of the needle head.

YOUR BENEFITS

- ⊕ The use of ultrasonic technology loosens deposits inside the system
- ⊕ Avoidance of grey spots in the end product thanks to continuous injection quantity
- ⊕ Cleaning with and against the flow direction of the brine
- ⊕ All cleaning parameters are freely selectable and adjustable

ONE SYSTEM FOR EVERYTHING

- Basin to accommodate all Günther needle heads

ALL-ROUND HYGIENE

- Manual rinsing device for external cleaning with integrated filter system

EFFECTIVE CLEANING

- With powerful circulation pump and integrated detergent pump

DEEP CLEANING

- Thanks to integrated ultrasonic technology

EXCELLENCE IN PROCESSING

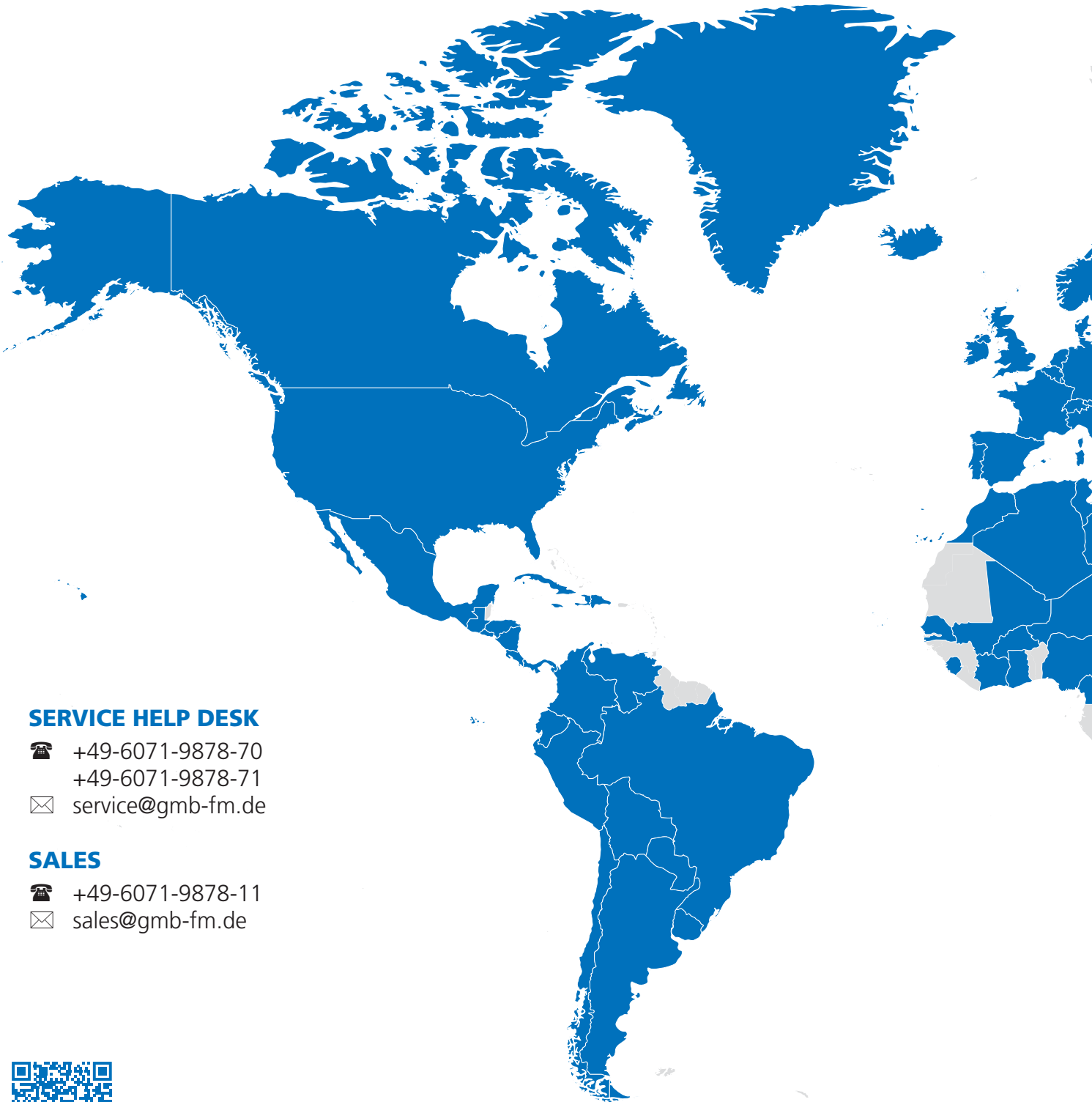

SERVICE HELP DESK

☎ +49-6071-9878-70
+49-6071-9878-71
✉ service@gmb-fm.de

SALES

☎ +49-6071-9878-11
✉ sales@gmb-fm.de



MORE INFORMATION?

Visit the section
on our website.

PARTNER/SERVICE

GET IN CONTACT

Right where your are – through our partner network, we are present in 105 countries. This means that we can provide you with the best possible support in all matters. We look forward to achieving our common goal with you: EXCELLENCE IN PROCESSING!

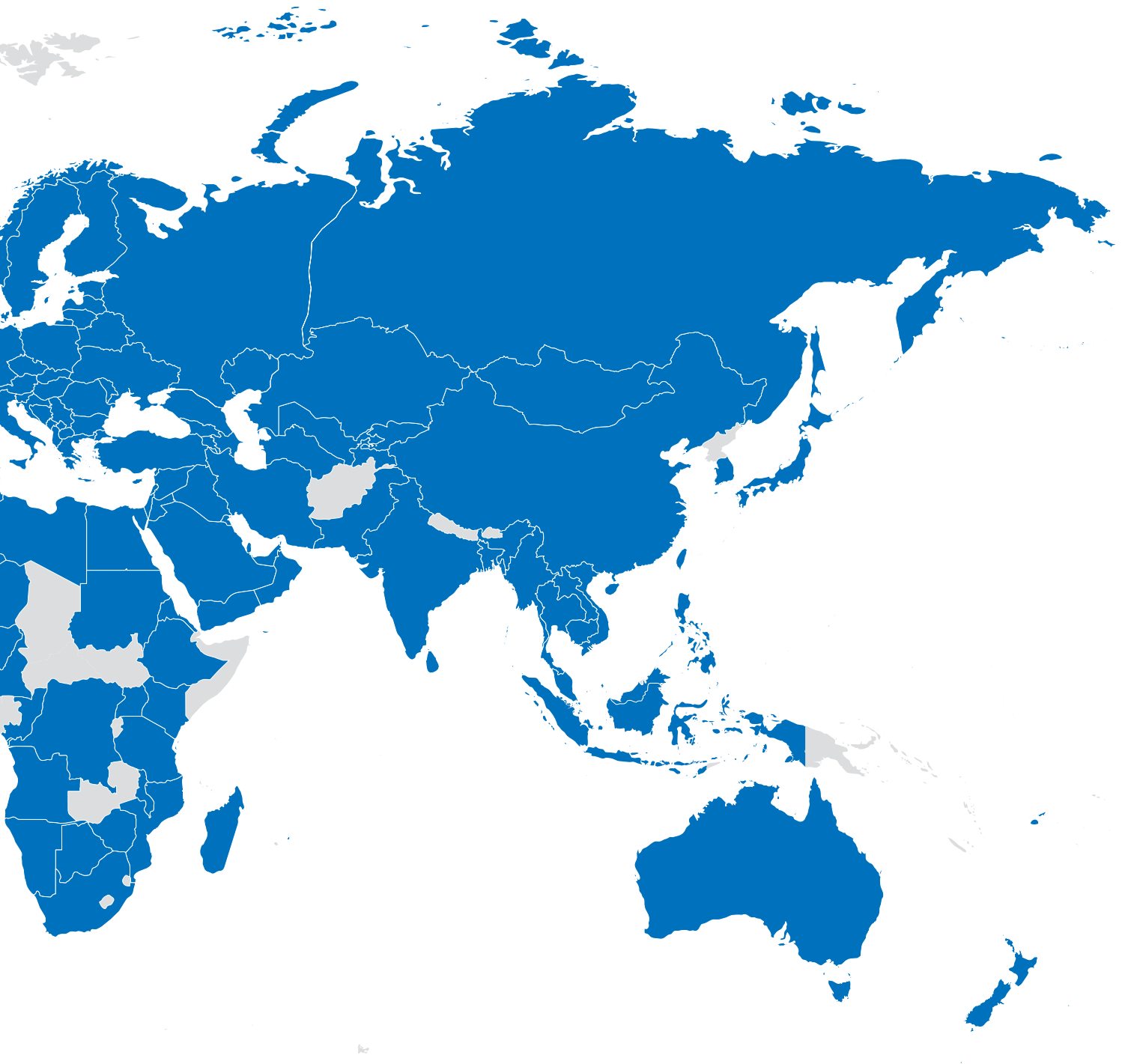



FOOD TECHNOLOGY FOR THE FINEST



günther[®]

Günther Maschinenbau GmbH
Einsteinstrasse 3-5
64859 Eppertshausen
info@gmb-fm.de
Tel: +49 6071 9878-0

Subject to changes – 25-10-2021