

KARL SCHNELL

PARTNER TO THE FOOD INDUSTRY



Translation of the Original Assembly instruction for a partly complete machine

Uà•^!ç^Âÿ ã@ Á@ Á!ã ã æÁ
{ æ&@ ^Á[& { ^} æã } ÊÁ
&[{][] ^} • Áæ ãÁ^ç] Áã~!Á
¬[{ Á@ Á& !!^} ó&[} ã~!æã } È

Contractor
Operator
Constructor KARL SCHNELL
Pos./Layout no.:
Machine/component Mixer 1000
Type 754
Machine no.: 15459
Order no.:
Plant no.:

Contents

1	General information	6
1.1	Manufacturer	6
1.2	Document data	6
1.3	Machine data	6
2	User information	7
2.1	Purpose of the assembly instruction	7
2.2	Use and structure of the documentation	7
2.3	Type of presentation	7
2.3.1	Action instructions	7
2.3.2	Enumerations	8
2.3.3	Safety information	8
2.3.4	Signal words	8
2.3.5	Icons	9
2.3.6	Safety symbols on the machine	9
2.3.7	Cross-references to other documents	10
2.3.8	Information and tips	10
2.3.9	Locations in the assembly instruction	11
3	Description of the machine	12
3.1	Use as intended	12
3.2	Function description	12
3.3	Specification of the products to be processed	12
3.4	Foreseeable misuse	12
3.5	Processing materials	12
3.6	Place of installation	13
3.7	Technical Specifications	13
3.7.1	Dimensions/weights	13
3.7.2	Electricity	13
3.7.3	Permitted environmental conditions	13
3.7.4	Emissions	13
3.8	Elements on the machine	14
3.9	Machine dimensions Mixer	15
3.10	Design modifications to the machine	16
3.11	Safety devices on the machine	16
3.11.1	Repair switch (customer made)	16
3.11.2	EMERGENCY-STOP button (customer made)	16
3.11.3	Safety switch	17
3.11.4	Safety switch with transfer system	18
3.11.5	Safety catch on the pneumatic cylinder of the mixer lid	19
3.11.6	Checking the safety devices	19
3.12	Protective devices	20
3.12.1	Location of the protective devices/protective lids	21
3.12.2	Deaeration bin	22
3.12.3	Pressure sensor on the bearing flange	23
3.13	Workstation of the personnel	23
3.14	Type plate	23
4	General safety information	24
4.1	Mechanical dangers	24

4.2	Pneumatic dangers	25
4.3	Electrical dangers.....	25
4.4	Chemical dangers	25
	4.4.1 Thermal dangers	26
4.5	Measures in the case of emergency	26
4.6	Responsibilities of the operator.....	26
4.7	Responsibilities of personnel	26
4.8	Training of personnel.....	26
4.9	Qualification of the personnel.....	27
4.10	Personal protection equipment	27
4.11	Faulty protection and safety devices.....	27
4.12	Retrofits or modifications.....	27
4.13	Spare and wear parts as well as auxiliary means	27
5	Transport and assembly	28
5.1	Safety information for transport and assembly.....	28
5.2	Transport damages	29
5.3	Permissible devices and auxiliary aids for the transportation	29
	5.3.1 Travelling transport	29
	5.3.2 Floating transport.....	29
5.4	Temporary storage	30
5.5	Ambient conditions for the assembly	30
5.6	Raise and transport undercarriage.....	31
5.7	Installing undercarriage	32
5.8	Raise mixer with crane and transport it.....	33
5.9	Transport mixer with fork lift	34
5.10	Install load cells and mount mixer onto the undercarriage.....	35
5.11	Install cleaning platform (on site)	37
6	Connections	38
6.1	Safety information for the connection of the machine	38
6.2	Electrical connection	40
	6.2.1 Connecting the potential equalisation.....	40
	6.2.2 Connecting the machine to the power supply.....	40
	6.2.3 Rotation direction check	41
6.3	Compressed-air connection	42
6.4	Water connection	43
6.5	Steam connection	44
6.6	Manhole lid.....	45
6.7	Connection for admixtures	46
7	Operation	47
8	Preparing for operation	48
8.1	Safety instruction for the commissioning.....	48
8.2	Before starting up the machine	48
8.3	Training	49
8.4	Initial startup.....	49
8.5	Acceptance	49

9	Normal operation	50
9.1	Safety information for the normal operation	50
9.2	Feeding	51
9.2.1	Feeding via a Screw Conveyor	51
9.3	Discharge	52
9.3.1	Discharge into emulsifier	52
9.4	Switch machine on and off	53
9.4.1	Switch on machine	53
9.4.2	Switch off machine in the emergency case	53
9.5	Troubleshooting and remedy	53
9.5.1	General safety information	53
9.5.2	Requirements for the operating personnel	53
9.5.3	Table of faults	53
10	Cleaning	56
10.1	General safety information	56
10.2	Cleaning instructions	56
10.3	Cleaning process manual	56
10.4	Cleaning schedule, manual	57
11	Maintenance	59
11.1	Safety information for the maintenance	59
11.1.1	Mechanical dangers	59
11.1.2	Electrical dangers	60
11.1.3	Chemical dangers	60
11.1.4	Thermal dangers	60
11.2	Inspection and maintenance	61
11.2.1	Maintenance- and inspection schedule	61
11.2.2	Lubrication points overview	63
11.2.3	Lubrication plan	64
11.2.4	Gear unit venting	64
11.2.5	Instruction for gear oil change: mixing shaft drive	65
11.2.6	Check/readjust seals	66
11.2.7	Check flange sleeve of discharge worm	67
11.3	Repair	68
11.3.1	Replace gear of the mixing shaft drive	68
11.3.2	Replace coupler and spring on the mixing shafts	70
11.3.3	Replace gear of the discharge worm	72
11.3.4	Replace gear of the discharge worm	74
11.3.5	Replace coupler and spring on the discharge worm	76
11.3.6	Check/replace bearing of outlet side	79
11.3.7	Check/replace bearing on the drive side of the mixing shaft and discharge worm	82
11.3.8	Stuffing box	85
11.3.9	Replace flange sleeve of discharge worm	89
11.3.10	Check/replace rubber seal of the mixer bin/man hole lid	91
11.3.11	Check/replace rubber seal of the cleaning flap	92
12	Shutting-down, storage and disposal	94
12.1	Safety information for the shutting-down, storage and disposal	94
12.2	Shutting down the machine	95
12.3	Storing the machine	95
12.4	Restarting the machine	95
12.5	Disassemble machine	95
12.6	Disposing of the machine	95

13 Spare parts	96
13.1 Spare parts list see document folder.	96
14 Appendix	97
14.1 Tightening torques of the screws	97
14.2 Tightening torques of the TAPER-LOCK springs	98
14.3 Tightening torques of the springs.....	99
15 Documents inclus	100
16 EC Declaration of Incorporation	101

1 General information

1.1 Manufacturer

KARL SCHNELL GmbH & Co.KG

P.O. Box 1309

Mühlstraße 30

D-73645 Winterbach

Phone + 49 (0) 7181 962-0

Fax. + 49 (0) 7181 962-100

E-Mail: info@karlschnell.de

Internet: <http://www.karlschnell.de>

1.2 Document data

Document no.: B19-270en

Version no. 01

Date of creation: 24/06/2019

Last modification: 24/06/2019

Machine no.: 15459

Type: 754

1.3 Machine data

Machine designation Mixer 1000

Type 754

Machine number 15459

Note

The represented illustrations in the assembly instruction can deviate in single cases from the actual machine execution.

We reserve the right to make technical changes.

KARL SCHNELL GmbH & Co. KG

All rights reserved.

These documents may not be copied or made available to third parties without our approval.

2 User information

2.1 Purpose of the assembly instruction

This assembly instruction in hand

- describes the working method, installation, operation, maintenance and disposal of the machine and
- gives important information for a safe and efficient handling of the machine.

Keep the assembly instruction

- readily available on the machine for the operating and maintenance personnel;
- hand it over together with the machine when changing the location or when there is a change in ownership.

2.2 Use and structure of the documentation

This assembly instruction is divided into 5 focal points regarding its content:

1. User information
 2. Description of the structure and functions (assembly-group orientated view and functional view)
 3. General safety information
 4. Manuals divided according to the lifetime phases of the machine
 5. Hints for using the assembly instruction
- First read the user information. Familiarise yourself with the type of presentation in the assembly instruction.
 - When you set the machine, operate or want to repair it, read first the descriptions of the components and functions for the respective lifetime phase before reading the instructions.
 - In this way, you can receive a good overview of the machine and will be able to better evaluate hazards and operations that are to be done.
 - Read the general safety information in any case. They are the prerequisite for an operation that meets safety requirements. Warnings and special safety information are described directly before the operation instructions.
 - The instructions do not contain any assembly or function description, but show you step-by-step how to achieve your goal. It is essential to follow all the instructions on the prerequisites and auxiliary aids as well as all warning and safety instructions. Maintain the order of the steps described.

A missing manual or missing pages must be replaced immediately.

2.3 Type of presentation

2.3.1 Action instructions

The actions steps to be carried out by the operating personnel are represented as an enumerated list. The sequence of the steps is to be complied with. The system reactions of the respecting operating handling are marked by an arrow.

Example: item

- 1 Operating action step 1
- 2 Operating action step 2
- → Reaction of the system to the operation action

2.3.2 Enumerations

Enumerations without imperative sequence are represented as list with enumeration points. For example:

- Point A
- Point B

2.3.3 Safety information

Safety information

- warning of immediate or possible dangers;
- inform about measures to be taken for to avoid dangers;
- describe measures on risk minimisation;
- provide important information on how to behave to meet safety standards.

The safety information is marked by an icon and a signal word.

- The icon describes the kind of danger.
- The signal word describes the seriousness of the imminent danger.

Observe the safety information to avoid causing damage to yourself, to other persons, or to physical assets.

2.3.4 Signal words

A safety icon can never replace the text of a safety information - thus the text of a safety information must be read always completely!



Danger

Positions marked with this sign point out that death, severe injury will occur if the respective precautions are not observed!



Warning

Positions marked with this sign point out that death, severe injury may occur if the respective precautions are not observed.



Caution

Positions marked with this sign point out that slight personal injury may occur if the respective precautions are not observed!



Note

Positions marked with this sign provide indications on technical information and tips for users which should avoid damages to the system. This symbol designates no safety information.



Environment

Positions marked with this sign provide indications on possible hazards of the environment.

2.3.5 Icons



Warning of immediate or possible dangers;



**Rule: Obligation to behave in a special way or to carry out an activity.
Measures to be absolutely observed.**



Prohibition: Prohibits certain activities or conduct.

2.3.6 Safety symbols on the machine



⚠ DANGER!

Danger through unrecognisable, damaged or missing signs!

- ➡ Inadequate signs can cause injuries resulting in death.
- Immediately replace unrecognisable, damaged or missing signs.

The following symbols can be fitted directly to the machine or at the place of installation of the machine.

They indicate the direct hazard area and the type of hazard.



Electricity

Dangers through electrical devices and hazardous electrical voltage.



Warning of cut injuries

Danger of the finger/hands being cut.



Warning of hand injuries

Danger of the fingers/hands being crushed.



Beware of hot surface

Danger of the hands being burnt when touching.



Warning of cold

Danger of the hands being frozen when touching.



Warning of running machine

Possible danger through rotating machine parts.



Beware of swinging loads

Danger of a person being crushed when lowering takes place. Danger of parts falling down. Keep off below the raised load.



Danger of slipping

Danger of slipping on soil level.



Climbing prohibited

2.3.7 Cross-references to other documents



Cross-references to other documents are marked with an icon.
Reading documents. Reference to the title of the document.

2.3.8 Information and tips

The information consists of

- tips that can be used and special useful information.
- no warning of hazards,
- no information relevant to safety.

2.3.9 Locations in the assembly instruction

All direction indications and locations in this manual refer to the outlet side of the machine.

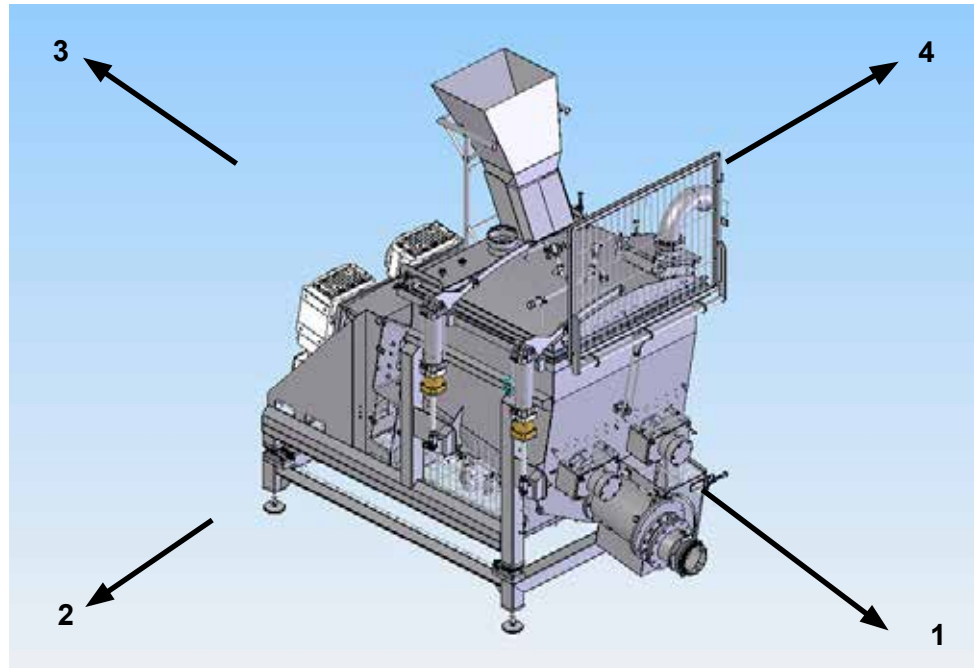

1. front
2. right
3. rear
4. left

3 Description of the machine

3.1 Use as intended

- The operational safety of the machine is ensured only when it is used as intended.
The machine is solely determined for the industrial range.
Improper use or use not as intended may result in personal injury or damage to property.
For damage arising from any use not as intended
- the operator bears the sole responsibility;
 - the manufacturer bears no liability.

3.2 Function description

The mixer bin is positioned on an undercarriage with 4 feet. Four load cells are installed between the undercarriage and the mixer bin. The mixer bin is closed with a lid on its top. The mixing shafts and the discharge screw are driven via geared motors, thus the power transmission occurs through a coupler. The product is fed into the mixer bin over a recess in the lid which is to be protected by the client. The two parallel running mixing shafts mix the product. The discharge occurs through the discharge worm into flanged emulsifier of KS.

3.3 Specification of the products to be processed

- The machine is designed for the processing of
- Pet Food

3.4 Foreseeable misuse

The machine is solely determined for the processing of the specified products.
No mineral and metallic products, and highly inflammable products may be conveyed with this machine.
The machine may be operated only in a technical proper condition. The protective devices which are installed by KS must be available, installed properly and fully operational unless it is not purposeful for the maintenance and repair. They must not be modified, avoided or made ineffective in their position. Safety components like limit switches, valves and other control components must not be put out of service.



Information!

Persons, who are on alcohol, drugs or medicaments which influence the reactivity, are not allowed to operate or install the machine.

Frozen product may not be stored in the mixer bin over a longer period since the product can freeze to a solid mass and lead to the damage of the mixing shafts/drive when restarting.

3.5 Processing materials



⚠ CAUTION!

The machine can be damaged through foreign bodies and hard parts in the processing material.

- The processing material, when inserted into the machine, must be free of hard parts and foreign bodies (e.g.: metal parts, wood, earth, plastics).

The machine is designed for the use in the foodstuff-/pet food sector.

Production of	Pet food
Processing materials	broken and ground meat

Particle size processing material	60-80mm / 2,36"-3,15" Container max. 800kg/1765lb.
Temperature of processing material	0,4°F - 14°F / - 18 °C to max. -10 °C



Information!

Please contact us if you have any questions concerning the processing material.

3.6 Place of installation

The machine complies, in respect of the electromagnetic compatibility, with the requirements of the standards

- 2014/30/EU

The machine is not suitable for use in living quarters in view of the interference emission.

3.7 Technical Specifications

3.7.1 Dimensions/weights

Dimensions and weights	Dependent on the machine execution. See the machine data sheet in the documentation folder.
-------------------------------	--

3.7.2 Electricity

Supply voltage and power consumption	Dependent on the machine execution. See the machine data sheet in the documentation folder.
Control voltage	Dependent on the machine execution. See the machine data sheet in the documentation folder.
On-time	Relative On-time: 100%

3.7.3 Permitted environmental conditions

Ambient temperature	-1°C to 30°C
Relative humidity	max. 80% r.h.
Operation above sea level	max 2000 m above sea level, soil condition
Soil condition:	stable, level, horizontal

3.7.4 Emissions

EMC	In accordance with the EMC guideline and the valid EMC standards for the use in the industrial sector.
Noises	Emission value in respect of the workplace during rating: 70dB (A)

3.8 Elements on the machine

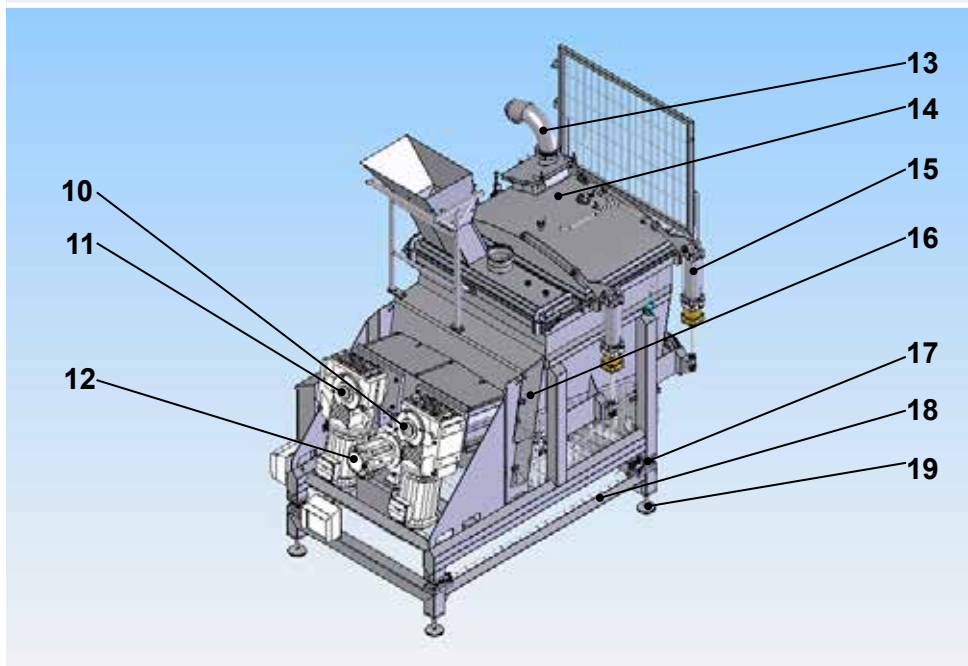
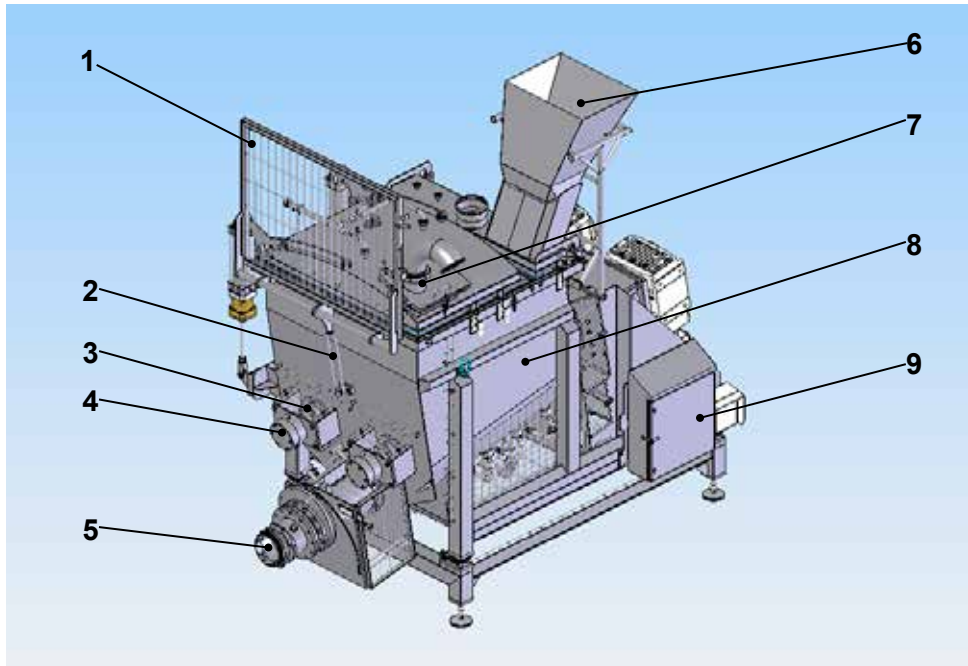

Pos.	Designation	Pos.	Designation
1	Protective grid	11	Drive gear, mixing shaft 2
2	Gas pressure spring protective grid	12	Drive gear, discharge screw
3	Stuffing box sealing, mixing shaft	13	Venting valve
4	Mixing shaft bearing	14	Bin lid
5	Connection flange, emulsifier	15	Pneumatic cylinder, bin lid
6	Filling apron	16	Mixing shaft bearing, drive side
7	Manhole lid	17	Load cell
8	Mixer bin	18	Undercarriage
9	Pneumatic cabinet	19	Rubber foot
10	Drive gear, mixing shaft 1		

3.10 Design modifications to the machine

No modifications, attachments or reconstructions of the machine may be effected without approval.
All conversion measures require the written approval of **Karl Schnell GmbH & Co.KG**.

3.11 Safety devices on the machine



⚠ DANGER!

**Operate machine only if all protection and safety devices are complete and operable.
Check the safety and protection devices regularly.**

The safety devices are used for the protection of the staff and machine of injuries or damages.

- The main switch resp. repair switch must be freely accessible at any time.
- The EMERGENCY-STOP switches must be freely accessible at any time.
- Operate the machine only with operable safety and protective devices.
- All safety- and protective devices must be checked on their functioning before starting with work. The safety switches must be checked with the utmost caution and care.



Information!

**The machine was executed without a switchbox.
The machine may not started up in the delivered state.
The customary prescriptions and regulations must be adhered to before the initial start-up.
The safety devices must be connected as described before the first start-up.
This incomplete machine only may be put into operation if it has been determined that the machine, into which this incomplete machine/plant is to be installed, corresponds to the machine directive 2006/42/EG.
The machine is integrated into the Production Line - Pet Food no.: 80155.**

3.11.1 Repair switch (customer made)

During maintenance-/repair work on the machine set the main/repair switch always to position 0 and protect against unauthorised restarting.



Information!

**The machine was executed without a switchbox.
The main/repair switch must be protected by the customer before the first start-up.**

3.11.2 EMERGENCY-STOP button (customer made)

An EMERGENCY-STOP device has to be attached to the machine which stops all hazardous movements during operating.



Information!

**The machine was executed without a switchbox.
The EMERGENCY-STOP button must be protected by the customer before the first start-up.**

3.11.3 Safety switch

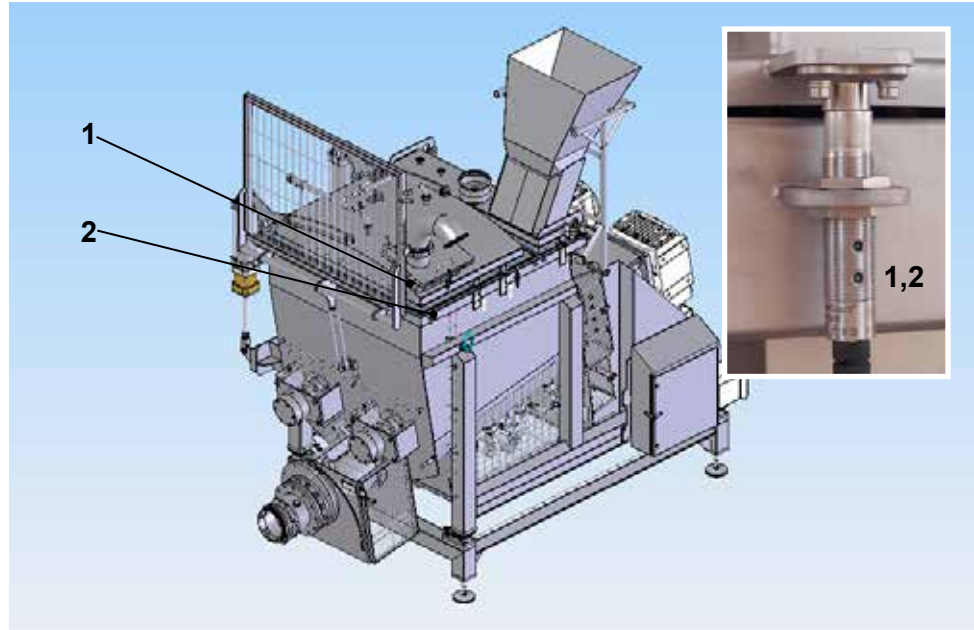

Pos.	Designation	Pos.	Designation
1	Safety switch of manhole lid	2	Safety switch of mixer lid

- All machine functions are locked when the mixer lid is opened.
- All machine functions are locked when the manhole lid is opened.



Information!

Only operate the machine if the safety switches are in working order.

3.11.4 Safety switch with transfer system

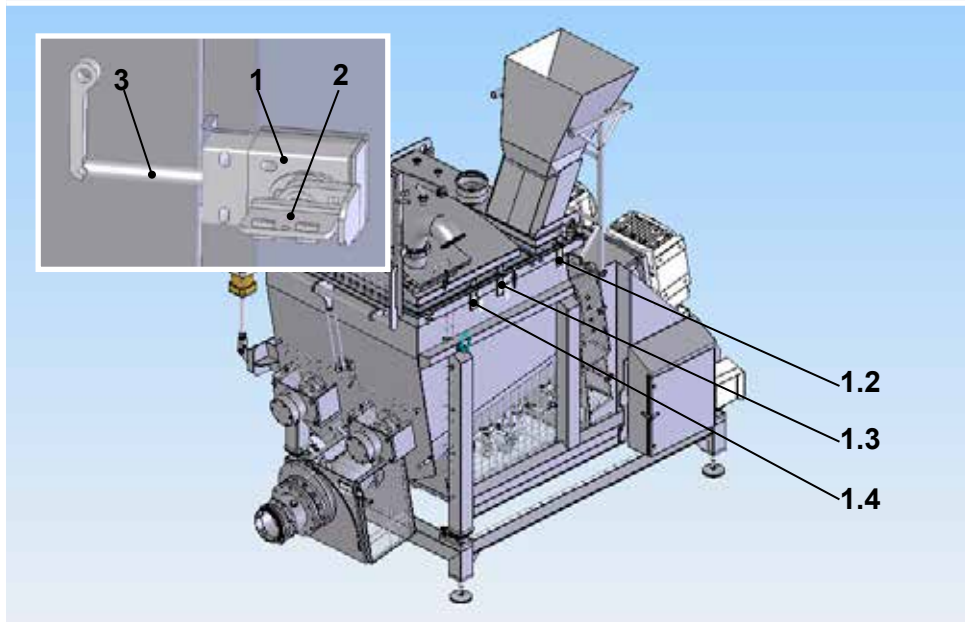
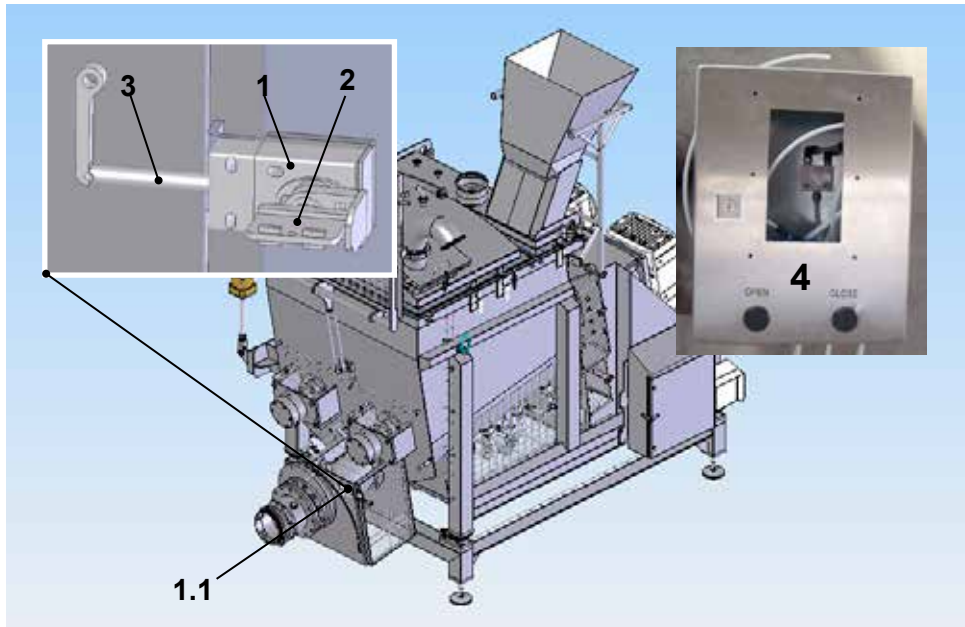

Pos.	Designation	Pos.	Designation
1.1	Safety switch, protective grid, cleaning flap	2	Key
1.2	Safety switch, mixer lid	3	Bolt
1.3	Safety switch, mixer lid	4	Key cabinet

■ The safety switches (1.1 -1.3) are attached by the client.

1. Insert key (2) and turn it to the right
 - > Locking bolt (3) can be removed.



Information!

Shut off power to the machine before opening the cleaning flap or the mixer lid.

If the key has been removed in the key cabinet then the machine can not run; the control is interrupted.

The key in the key cabinet may be removed only for cleaning and maintenance work.

3.11.5 Safety catch on the pneumatic cylinder of the mixer lid

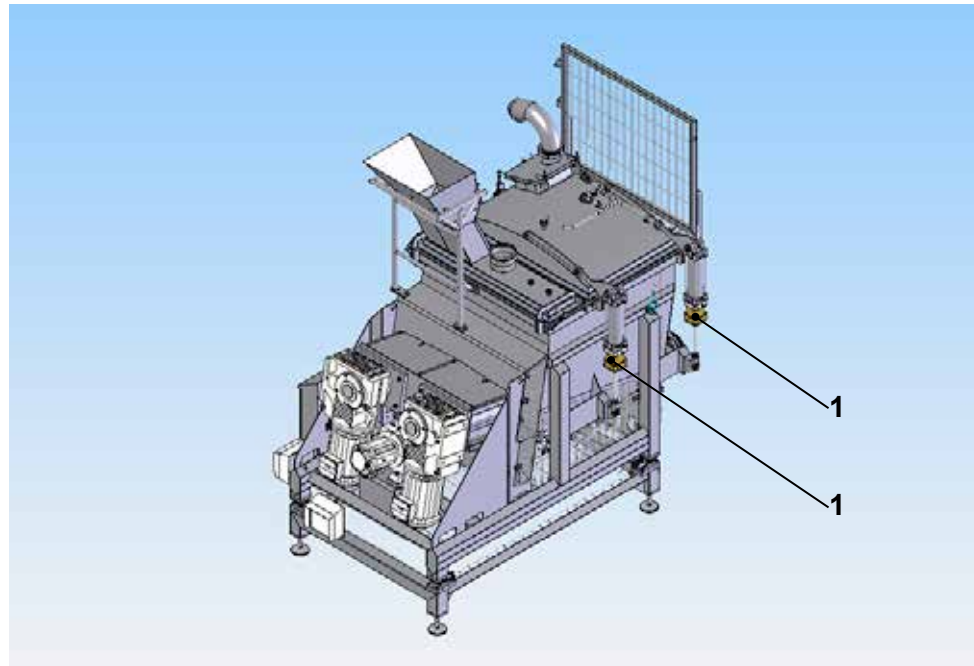

Pos.	Designation	Pos.	Designation
1	clamping unit on the pneumatic cylinder		

- The clamping unit clamps and holds the piston rods of the pneumatic cylinders with a calculated clamping force and acts in both moving directions. The clamping force is applied by the disc springs. Releasing takes place by means of pneumatic pressure.

3.11.6 Checking the safety devices



Information!

All safety devices must be checked daily before starting work for functionality and repaired if necessary.

All safety devices must be checked daily before starting work for functionality and repaired if necessary.

EMERGENCY-STOP (provided by the customer)

1. Push the EMERGENCY STOP button on the individual spots and engage.
 - > All functions must be switched off.
2. Unlock EMERGENCY-STOP button.
3. Restart plant.

2 Safety switch, mixer lid

1. Switch off mixing shafts.
2. Open mixer lid.
 - > All functions must be switched off.

Safety switch – manhole lid

1. Switch off mixing shafts.
2. Open manhole lid.
 - > Vaporisation cannot be started.

Safety switch with transfer system

1. Switch off machine.
2. Remove key from the key cabinet (will be fitted by the customer)
 - > all machine functions are locked.

Safety catch on the pneumatic cylinder of the mixer lid

1. Open mixer lid.
 - > Disconnect pneumatic supply.
 - > Piston rod of the pneumatic cylinder is stuck.

3.12 Protective devices



DANGER!

The protective devices/protective lids are used for the protection of the staff and machine against injuries or damages.

- Do not operate the machine without the installed protective devices/protective lidings.
- All protective devices/protective lids must be checked daily to ensure they are in working order, and repaired if necessary.

3.12.1 Location of the protective devices/protective lids

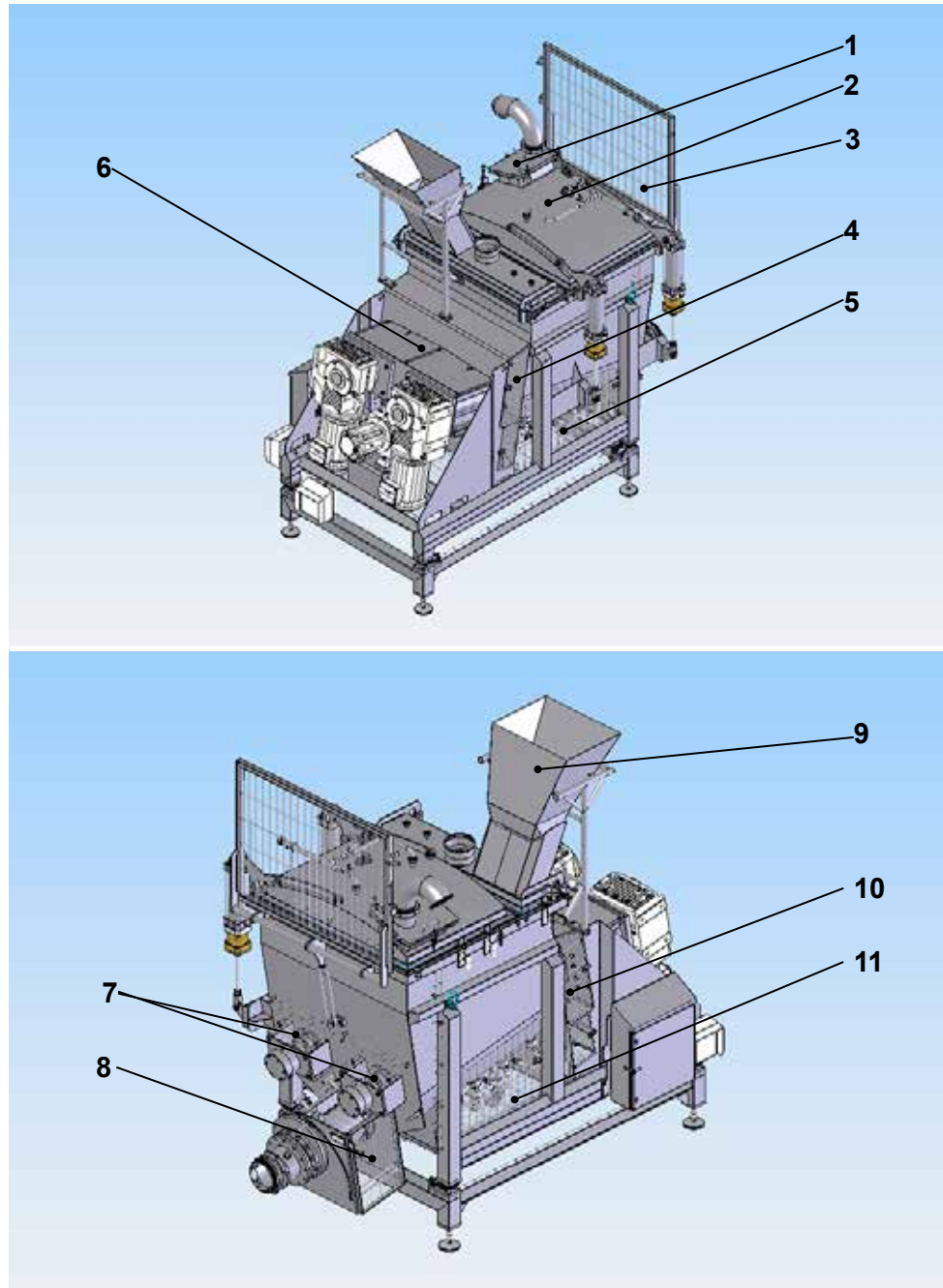

Pos.	Designation	Pos.	Designation
1	Man hole lid	7	Contact guard plate, shaft bearing
2	Mixer lid	8	Protective grid, cleaning flap
3	Protective grid outlet side	9	Filling apron
4	Contact guard grid, shaft bearing	10	Contact guard grid, shaft bearing
5	Contact guard grid vaporisation	11	Contact guard grid vaporisation
6	Coupler protection		

3.12.2 Deaeration bin



⚠ DANGER!

Overpressure in the mixer bin.

- ➡ Danger of being burnt through steam.
- Do not close the aeration hopper or connect to a closed pipe system,
- otherwise an overpressure develops in the bin.



⚠ CAUTION!

The bin and its attachments strongly heat up when operating with hot steam.

- ➡ Danger of being burnt through escape of hot steam at the aeration pipe.
- Avoid touching the bin and the steam line.

Function deaeration bin



Information!

The deaeration on the bin is used for blowing off steam.

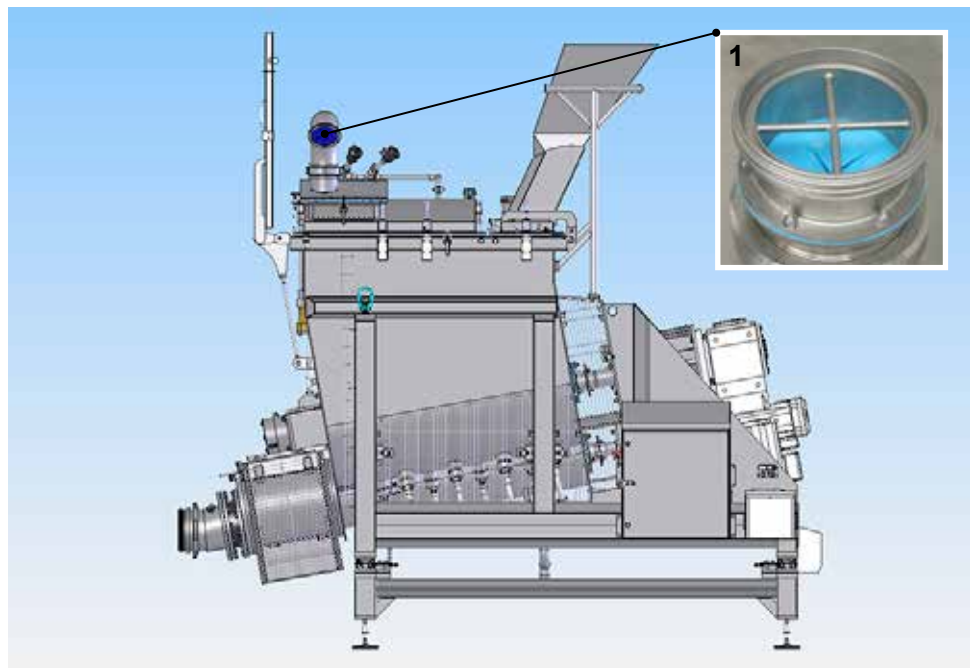

3.12.3 Pressure sensor on the bearing flange

Function pressure sensor



Information!

The pressure sensor controls the speed of the discharge screw so that no overpressure develops on the connected emulsifier.

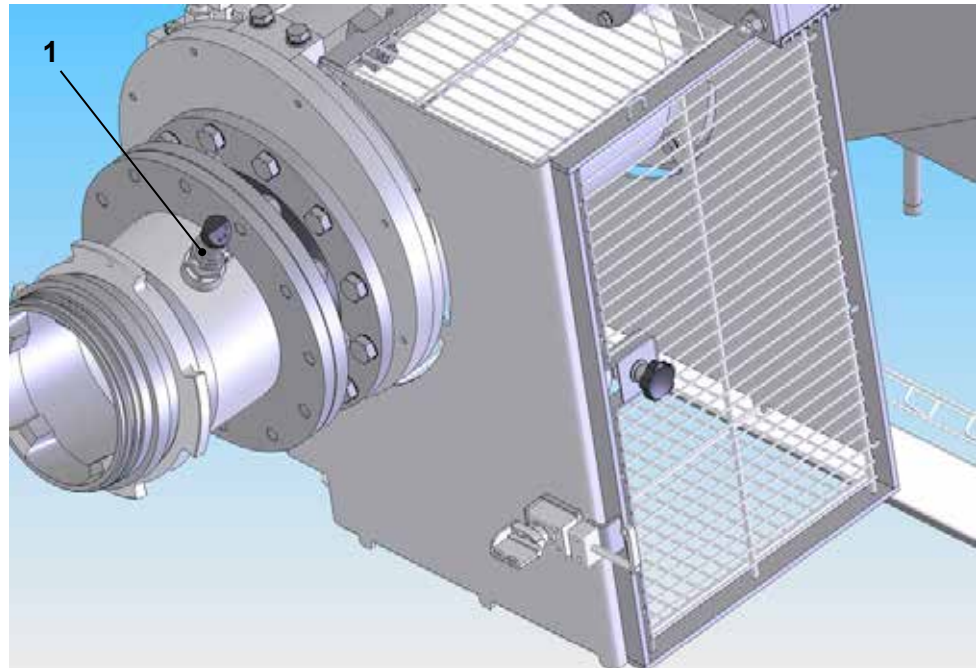

3.13 Workstation of the personnel

The machine must be only operated by a single person. The operation takes place from a central control panel.

3.14 Type plate

The type plate of the machine is fitted on the drive side.

There you find important information

- about the machine,
- about the energy supply,
- about the manufacturer.

4 General safety information



Information!

Keep the assembly instruction always at the place of work of the machine! The assembly instruction must be readily available for the operator and maintenance personnel.

Danger and impairments can occur when using the machine

- for life and limb of the operator or third parties;
- for the machine itself;
- to other physical assets.

The basis of the safe handling and trouble-free operation of this machine is a thorough knowledge of the safety and user information contained in this manual.

Serious injuries to people and damage to property are possible with

- improper installation and setting,
- improper use,
- unauthorised removal of lids or safety devices.

Furthermore general and local regulations on accident prevention and environmental protection are to be observed.

There are hazards on the machine which cannot be removed from the design side.

Absolutely observe the safety information on the machine and in the assembly instruction.

4.1 Mechanical dangers

For all parts which move in relation to each other, there is a personal danger of cutting, crushing or being caught and pulled into the machine.



Danger location	Type of danger	Reduction of danger
Mixing shafts.	Mortal danger! Danger of being caught into the bin tub.	Protected through bin lid. Lided through the outlet of the upstream connected machine.
Drive and coupler.	Danger of the fingers/hands being crushed, caught, seized. Danger of the lower limbs being crushed by parts falling down during maintenance work.	Protected through contact guard plate. Special care to be taken during maintenance work. Preventive regular maintenance.
Cleaning flap.	Danger of the fingers/hands being crushed when closing the cleaning flap.	Special care to be taken when opening the cleaning flap.
Protective outlet grid, cleaning flap.	Danger of the fingers/hands being crushed when closing the outlet protective grid or the cleaning flap.	Special care to be taken during maintenance work.
Mixer lid, manhole lid.	Danger of the fingers/hands being crushed when closing the lids.	Special care to be taken when closing the lids.
Climbing aid/ladder.	Falling down/slipping on the climbing aid/ladder.	Use suitable climbing aids.

4.2 Pneumatic dangers

During normal operation, there is no danger resulting from pneumatic components on the machine. Only in the following conditions may dangers arise from the pneumatics.



Danger location	Type of danger	Reduction of danger
Compressed air-lines burst.	Injuries caused by compressed-air hose.	Special caution. Preventive and regular maintenance.
	Malfunction caused through quick drop in air pressure.	
	Uncontrolled cylinder movement.	

4.3 Electrical dangers

During normal operation no danger occurs as a result from the electrical equipment of the machine. Only in the following conditions may dangers arise from the electrical equipment.



Danger location	Type of danger	Reduction of danger
Injury from cables.	Danger to life! Electric shock 230/400V caused by electrical voltage.	Do not overrun cable. Connect protective conductor system. Switch voltage supply always off and protect against unauthorized restarting during maintenance and repair work.
	Injection of water into the opened control cabinet resp. terminal box.	
Touching of live sections.	Danger to life! Electric shock 230/400V caused by electrical voltage.	Connect protective conductor system. Live parts must not be accessible. Regularly check continuous protective conductor devices.
Voltage-storage components installed (frequency converter).	Dangerous residual voltage.	Pay attention to discharging time. Check clamping points on residual voltage (observe the safety rules according to BGV A3).
Cable being burnt in the control cabinet.	Danger of being burnt.	Extinguish with suitable powder fire extinguisher.
Motor.	Danger due to overload.	Overload protection is control-technically integrated.

4.4 Chemical dangers

During normal operation no chemical danger occurs as a result from the machine. Only in the following conditions may chemical dangers arise.



Danger location	Type of danger	Reduction of danger
Entire machine. Cleaning. Using detergents.	Danger through contact with or inhalation of dangerous liquids, gases, hazes, steams or dust.	Wear personal protective clothing / gloves, goggles, protective suits. Observe safety data sheet of the detergent manufacturer.

4.4.1 Thermal dangers

In the normal operation no danger occurs when operating the machine. Only in the following conditions may dangers arise from the vaporisation.



Danger location	Type of danger	Reduction of danger
Vaporisation.	Burns through escape of hot steam. Steam temperature max. 135°C or product max. 90°C.	Avoid touching the pipelines. Check the pipeline screwing regularly for tightness.
	Danger of being burnt when touching the coupling bows, steam/product pipelines.	Always wear heat-resistant protective gloves when performing maintenance- and repair work. Wait for the cool down.

4.5 Measures in the case of emergency



Information!

Main switch and EMERGENCY-STOP button must be attached by the customer before the first start-up.

Press the EMERGENCY-STOP button (if available) in the case of emergency or disconnect the machine immediately from the power supply.

The main switch is used as the disconnection device of the mains.

- The OFF position is marked with "0".
- The ON position is marked with "1".

The machine is disconnected from the mains in the OFF position.

The main switch can be locked in the OFF position by means of a padlock. (To be supplied by the customer.)

4.6 Responsibilities of the operator

The operator is obliged to let only persons work at the machine who

- are familiar with the principle regulations on safety at work and accident prevention;
- are instructed on the work at the machine;
- have read and understood this assembly instruction.

As operator you are furthermore obliged to adhere to the requirements of the operational safety.

4.7 Responsibilities of personnel

All persons who are assigned with work at the machine are obligated before starting with work

- to observe the principle regulations on safety at work and accident prevention;
- to read and observe this assembly instruction.

Please direct any unanswered questions to the manufacturer.

4.8 Training of personnel

Only fully trained personnel are permitted to work with the machine. Personnel to be trained may work at the machine only under supervision.

Transport and installation, connection of the supply lines, commissioning as well as maintenance- and repair work may be executed only by qualified specialist personnel who have had instruction specific to the machine.

Specialists must have demonstrably the following knowledges apart from a perennial professional experience:

4.9 Qualification of the personnel

Activities	Person	Knowledges
Transport/storage.	Forwarding agents, dealers.	Proof of cargo securing instructions. Safe handling with lifting gears and sling.
Installation sanitary/ electricity, connections. Initial startup. Maintenance, repair. Decommissioning. Disassembly.	Specialists.	Safe handling with tools. Hauling and connection of pipelines. Laying of electrical lines. Assembly of distributors, fault current protection switches, circuit breakers, electrical machines, switches, buttons, sockets etc. Measurement of the efficiency of electrical safety measures. Product-specific knowledge.
Service, operation, monitoring, easy maintenance and fault-clearance.	Owner, user.	No specific requirements.
Disposal.	Specialists.	Proper and environment-friendly disposal of materials and substances. Decontamination of harmful substances. Knowledge of recycling.

4.10 Personal protection equipment

No personal protective clothing is necessary to operate this machine. For the repair and fault-clearance, the operator must provide the following personal protective clothing

- protective gloves;
- goggles;
- protective helmet;
- protective shoes;
- ear protection;
- skin-protection agent.

The noise emission of the machine does not require an ear protection. Nevertheless, a noise level can be reached at the workstation at which the personnel must wear an ear protection. See for it the workstation-specific threat analysis of the operator.

4.11 Faulty protection and safety devices

Faulty or disassembled safety devices can result in dangerous situations. For this reason

- switch off machine immediately.
- Protect against restarting.
- disconnect electrical power supply if necessary.

4.12 Retrofits or modifications

Each supplementations or modifications on the machine are not permitted without the written approval of the manufacturer. If you are planning retrofits, get in contact before with the manufacturer.

4.13 Spare and wear parts as well as auxiliary means

The use of spare and wear parts of other manufacturers can lead to hazards. Use only original parts or parts that are released by the manufacturer.

The manufacturer does not assume any liability for damages resulting from the use of spare and wear parts or auxiliary materials which are not released by the manufacturer.

5 Transport and assembly

5.1 Safety information for transport and assembly



⚠ DANGER!

Machine parts which are put down incorrect or fitted improperly can fall down or topple.

Parts which are lying loosely on top of each other can slip or fall down.

Floating loads can fall down.

Too high stacked parts can topple.

The transport may be carried out only by qualified persons under strict observation of the safety information.

- Lock the route of transport against unauthorised access.
- Transport the load close to the floor.
- Do not stay below floating loads.
- Do not stack the plant parts too high.
- Protect the parts against falling over.



⚠ DANGER!

Danger through assembly work which is not properly carried out.

- The assembly may be carried out only by qualified persons under strict observation of the safety information.
- Close the installation area of the machine against unauthorised access.
- Do not damage machine elements and components and install only in clean, fully functional state.
- Install all machine elements and components according to the described instruction.
- Adhere to the pre-set tightening torque.
- Observe the safety sheets regarding the used process media (e.g. gear oils, hydraulic oils, roller bearing grease, detergents).



⚠ DANGER!

Danger of falling into the mixer tub.

- ☞ Life-threatening cut injuries
- Keep off the mixer tub or the mixer rim.



⚠ CAUTION!

Danger of slipping and falling down from the ladders

- Use suitable ladders when installing/assembling the machine parts.

Danger of slipping and falling down from the walking surface/platform!

- The crossing area from the cleaning platform to the floor must be made anti-slip by the operator.
- Always clean the walking surface of the cleaning platform thoroughly of water and grease.



Information!

Severe damage can be caused at the machine if other load lifting appliances will be used than the indicated ones.

- Only use approved and sufficiently dimensioned load lifting appliances.

**Information!**

The assembly of the machine is normally done by specialists **KARL SCHNELL GmbH & Co.KG.** of the company.
In the event that the operator installs the machine himself, this may be carried out by specialists only and strictly according to the **KARL SCHNELL GmbH & Co.KG.** instructions of the company.

**Information!**

Severe injuries to people and damage to property can be caused through faulty screw tightening torques.

➤ Observe the table of the tightening torques in the Appendix.

Due to the strong vibrations all fastening bolts and screw connections have to be checked at regular intervals (monthly) regarding tight fit.

5.2 Transport damages

The machine or the machine parts are stored on pallets, wrapped in foil and secured with tension belts for the transportation.

Check the consignment immediately after receipt regarding transport damages.

If you detect any damages on the packing which suggest the damage of the content, then you must examine immediately the content regarding any damages.

The forwarding agent has to be notified immediately about possible detected damages and they have to be confirmed by him.

5.3 Permissible devices and auxiliary aids for the transportation

5.3.1 Travelling transport

The machine or machine parts may be transported only with suitable conveyors which are designed for the load and size of the plant.

During the transportation no objects may be placed on the machine or the machine parts.

Design modifications which are necessary to bring the machine to the installation location in the workshop must only be performed at the expense of the operator.

We do not accept any liability for damages on the machine or on the building through the transportation to the place of installation. For the transportation the plant is to be protected against:

- toppling
- externally applied force
- mechanical impacts and vibrations
- humidity
- Influence of heat

5.3.2 Floating transport

The machine or machine parts may be transported only with suitable hoisting devices which are designed for the load and size of the plant.

As hoisting device load handling devices and slings with crossbars must be used.

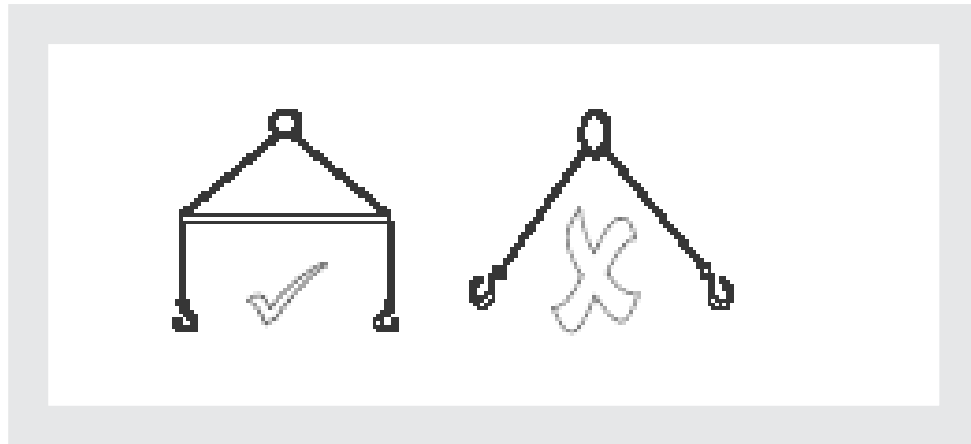

5.4 Temporary storage

The machine must be stored horizontal and torsion-free on a firm, stable subsoil. Just as during transportation the machine must be protected also when storing against:

- toppling
- externally applied force
- mechanical impacts and vibrations
- humidity
- influence of heat

During the transportation no objects may be placed on the machine or the machine parts.

5.5 Ambient conditions for the assembly



Information!

Direct action of frost without suitable frost protection measures can cause severe damages.

- The operator must ensure that the place of installation is free from direct action of frost.

The installation must be performed according to Installation schedule no.: 18-106-...

- Before beginning the assembly it must be checked if the dimensions of the place of installation and the constructional conditions do correspond with the necessary requirements and the dimension specifications in the planning documents.
- Floor base must be permitted for the weight of the machine.
- Floor base must be horizontal and even.
- The installation location must be selected in such a way that during the operation around the machine a minimum distance of approx. 500 mm is kept between the machine section projecting furthest and the next obstacle.
- In the case of travel and transport paths, larger distances apply according to standard.
- Sufficient free space must be ensured for feeding/discharging the machine on the feeding and discharge sides respectively.
- There must be a minimum 1 m space laterally around the machine for servicing purposes and also approx. 2 m on the inlet/outlet side, or the machine must be relocated.
- The operator must provide an adequate light source of min. 500 lux within the area of the machine.
- The substructure of the place of installation is to be dimensioned statically so that the operating weight of the mixer can be supported.

- The engines must remain well accessible and particularly the fan of the engine must have a distance of at least 100 mm to other objects.
- The place of installation must be ventilated and deaerated sufficiently.
- A detached operating panel must be installed so that a safe operation of the machine is ensured. All valid regulations are to be adhered to for this.
- The outlet area must be secured in such a way that it corresponds to the valid safety regulations.

5.6 Raise and transport undercarriage



Information!

The total weight of the undercarriage amounts to approx. 500 kg.

The machine feet are dismantled for the transportation to avoid damages on them. The machine must be laid underneath with squared timbers if necessary.

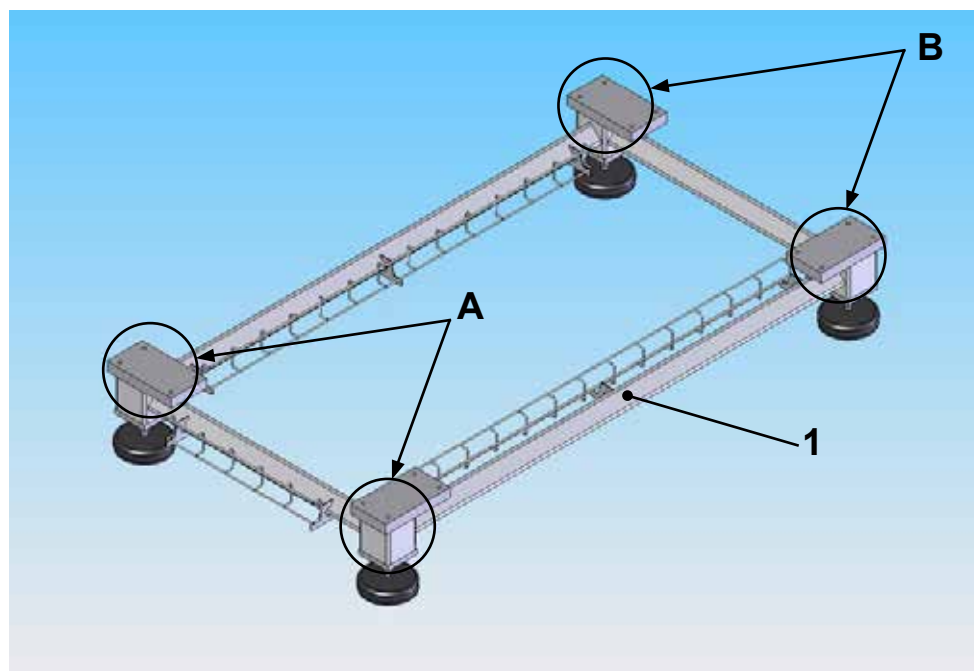

1. Put the rope/chain in the range A+B around the transverse pipes and fit them.
2. Raise undercarriage carefully and only a little at a time.
 - > Take care with the compensation for the centre of gravity!
 - > Adjust rope lengths, if necessary, in such a way that the machine parts hang straight on the crane.
3. Drive the fork lift so far forwards that the forks protrude approx. 20 cm over the lower cross-beams (1).
 - > Take care with the compensation for the centre of gravity!
4. Protect undercarriage against tilting over/falling over.
5. Transport undercarriage over the floor as close as possible to the place of installation.
6. Lower undercarriage carefully and slowly, do not reach thereby under the machine parts.

5.7 Installing undercarriage



Information!

The total weight of the undercarriage amounts to approx. 500 kg.

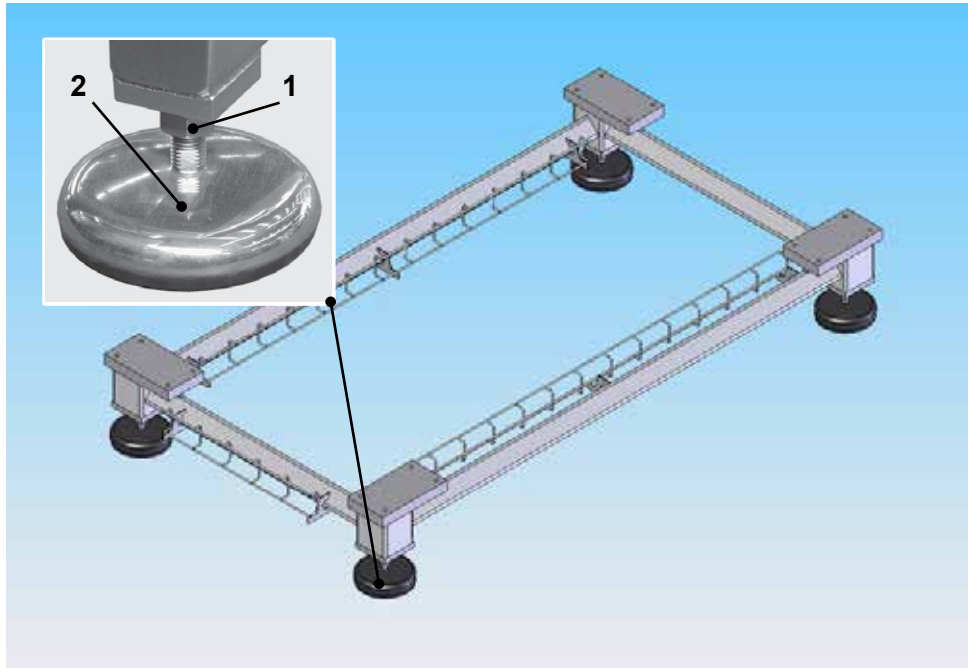

1. Undercarriage must be on a firm position on all 4 rubber feet.
2. Loosen lock nuts (1) of the rubber feet.
3. Set undercarriage flush with floor level.
4. Re-tighten the lock nuts (1) of the rubber feet (2) after the adjustment.

5.8 Raise mixer with crane and transport it



Information!

The total weight of the mixer amounts to approx. 4200 kg. The exact weight of the machine is entered on the type plate or in the machine master card.

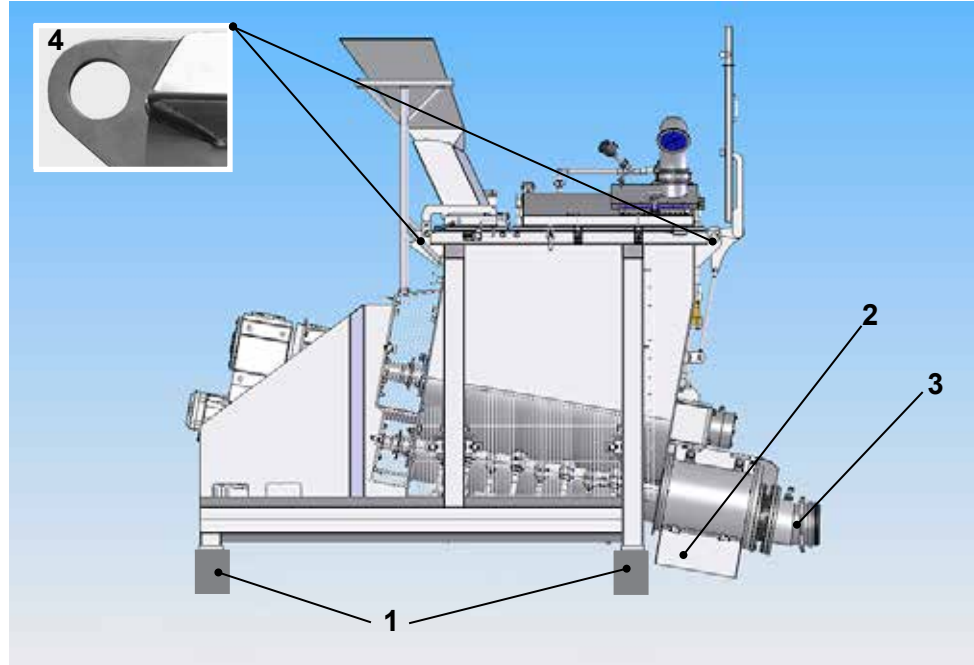

Squared timbers (1) must be laid underneath the mixer bin for transportation to avoid damages to the outlet protection (2) and to the pressure pipe section (3).

1. Attach rope/chain to the eyebolts (4),
 - > take care thereby that the pipelines, cables or protective lidings are not damaged by this.
2. Raise mixer carefully and only a little at a time.
 - > Take care with the compensation for the centre of gravity!
 - > Adjust rope lengths, if necessary, in such a way that the machine hangs straight on the crane.
3. Transport mixer over the floor as close as possible to the place of installation.
4. Place mixer on the undercarriage (see Chapter 5.10), do not reach thereby below the machine parts.
5. Disengage rope/chain.
6. Remount and fasten parts which are dismantled for transport purposes.

5.9 Transport mixer with fork lift



Information!

The total weight of the mixer amounts to approx. 4200 kg.
The exact weight of the machine is entered on the type plate or in the machine master card.

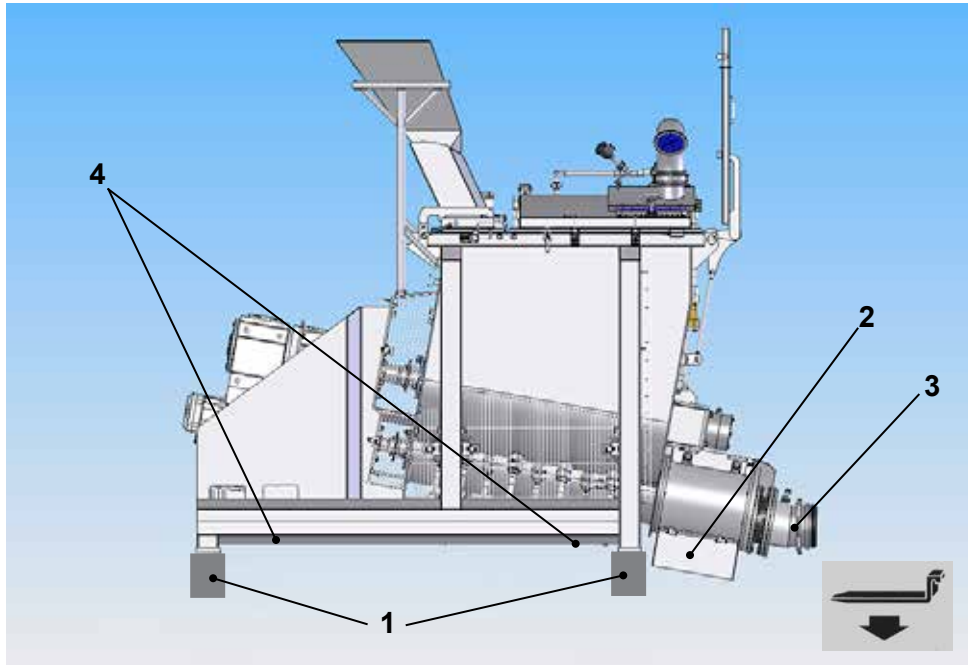

Squared timbers (1) must be laid underneath the mixer bin for transportation to avoid damages to the outlet protection (2) and to the pressure pipe section (3).

1. Drive the fork lift so far forwards that the forks protrude approx. 20 cm over the lower cross-beams (4),
 - > take care thereby that the pipelines, cables or protective lidings are not damaged by this.
2. Protect mixer against tilting over/falling over.
3. Raise mixer carefully and only a little at a time.
 - > Take care with the compensation for the centre of gravity!
4. Transport mixer over the floor as close as possible to the place of installation.
5. Place mixer on the undercarriage (see Chapter 5.10.)
6. Remount and fasten parts which are dismantled for transport purposes.

5.10 Install load cells and mount mixer onto the undercarriage

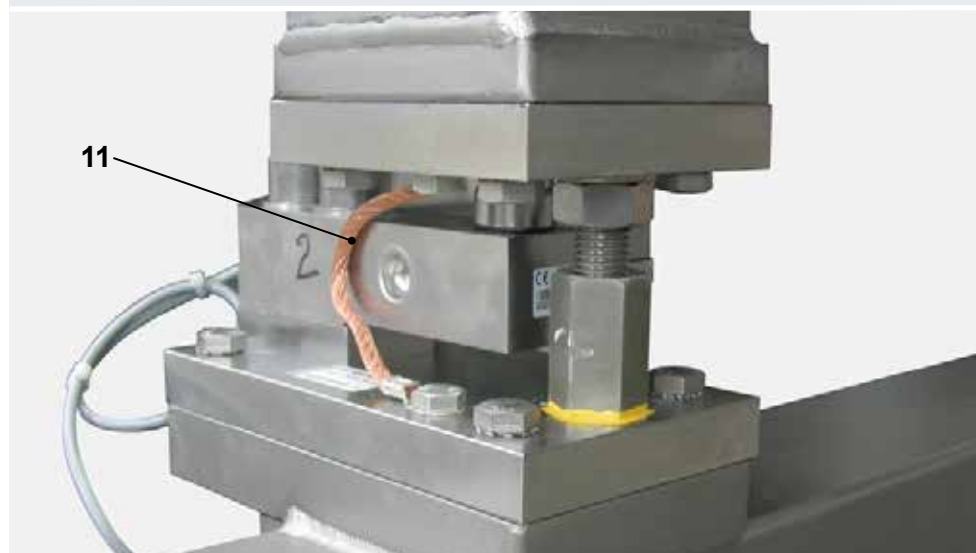
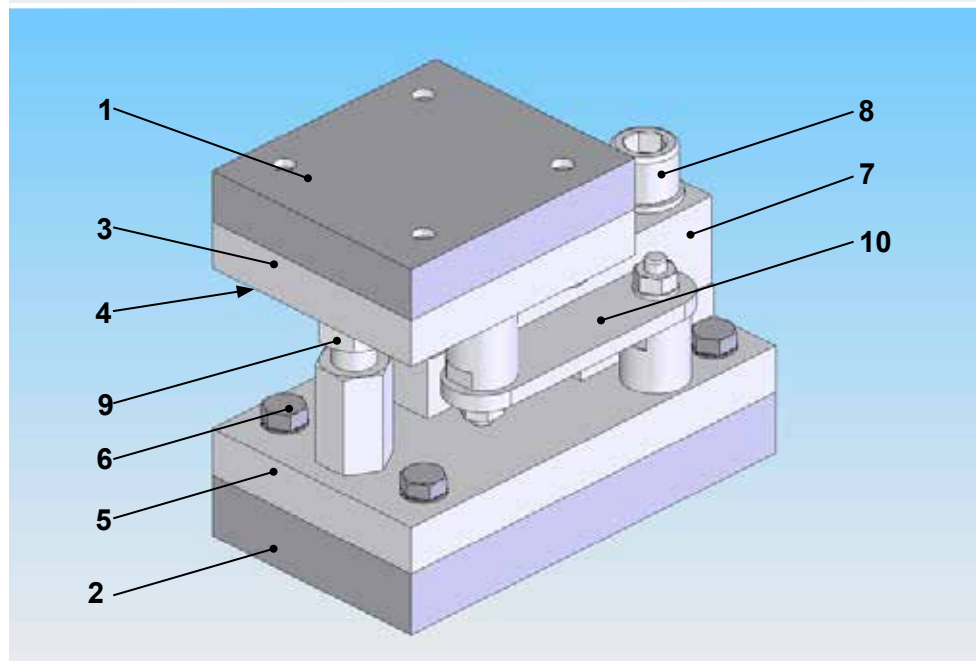
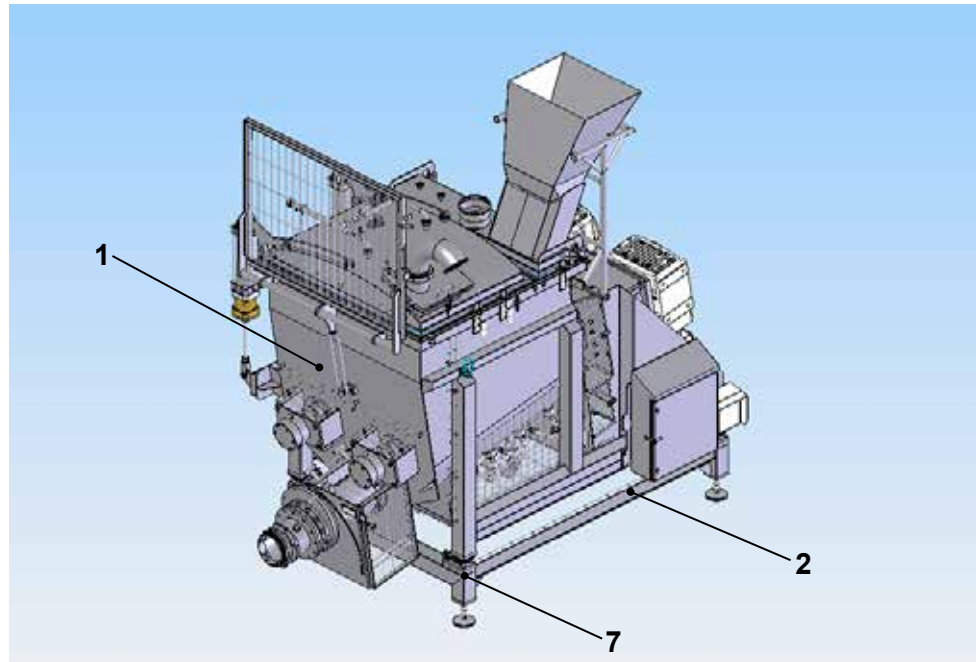

Item	Designation	Item	Designation
1	Mixer bin	7	Weighing module
2	Undercarriage	8	Fillister head screw
3	Upper assembly plate	9	Lock nut
4	Hexagonal screw	10	Linkage
5	Lower assembly plate	11	Earth cable
6	Hexagonal screw		



⚠ CAUTION!

Danger of fingers/hands being crushed, caught.

Information!

Observe assembly instruction of the weighing module HLC.

An incorrect connected earth cable (11) can cause the destruction of the load cells.

Due to the strong vibrations all fastening screws and screw connections have to be checked at regular intervals (monthly) regarding tight fit.

1. Raise mixer bin (1) with a crane/fork lift and lift it over the undercarriage (2).
2. Attach upper assembly plate (3) with the hexagonal screws (4) to the fastening plates in the mixer bin (1).
 - > Upper and lower assembly plate are pre-mounted together with the load cell.
3. Attach mixer bin (1) with the assembly plates to the undercarriage (2) and tighten it with the hexagonal screws (6) to the assembly plate (5).
4. Insert weighing module (7) completely and fasten it with the both fillister head screws (8) in the lower assembly plate (5).
5. Tighten the fillister head screws (8) evenly to the indicated tightening torque $MA = 400 \text{ Nm}$.
 - > To reach a higher stability oil the fastening screws before the installation.
6. Loosen lock nuts (9) and screw them downwards.
7. Mount linkage (10).
8. Connect earth cable (11) between the upper and the lower assembly plate.
9. Have the connection cables of the load cells be connected by an authorised electrician.

5.11 Install cleaning platform (on site)



⚠ CAUTION!

Danger of slipping and falling down from the climbing aids.

- When connecting.

Danger of slipping!

- Always clean the walking surface of the cleaning platform/climbing aids thoroughly of water and grease.



Information!

The crossing area from the cleaning platform/climbing aids to the floor must be made anti-slip by the operator.

The following points must be observed when installing:

- The operator must fit a cleaning platform/climbing aids before the initial start-up which corresponds to the valid safety regulations.
- For the installation of the cleaning platform/climbing aids, all valid regulations and rules according to DIN 14122-1 to 14122-3 must be adhered to.
- For the setting up, installation of the cleaning platform/climbing aids the safety distances according to DIN/EN 13857 must be adhered to.

6 Connections

6.1 Safety information for the connection of the machine



⚠ DANGER!

Danger through connection work which is not properly carried out.

Faulty connections can cause an unexpected starting of the machine or uncontrolled machine movements.

High body current-flows and burns by direct or indirect touching of live sections.

Cables, hoses and lines which are not or faulty connected can lead to malfunctions which endanger the safety of the operating personnel.

Interchanged connections cause a wrong running direction of the motor.

Faulty wired connections can destroy the electrical / electronic components.

Electrostatic processes / power failures can endanger the electronic components and lead to errors in the software.

Improper run lines (e.g. too small bending radius) can cause smouldering and cable fires.

Live wire ends and components can lead to injuries through electrical current.

Danger of being burnt through escape of hot water/steam.

- The connection may be carried out only by qualified persons under strict observation of the safety information.
 - Before all works on the electrical system of the machine unplug the connector plugs.
 - Close the installation area of the machine against unauthorised access.
 - Attach the danger sign "Caution: repair work".
 - Do not damage machine elements and components and install only in clean, fully functional state.
 - Install all machine elements and components according to the described instruction.
 - Adhere to the pre-set tightening torque.
-
- Run all connections - cable, hoses and lines so that no trip hazards occur through them.
 - Keep to the prescribed bending radii when running cables, hoses and lines.
 - Keep to the specified layout according to the connection diagram when running cables, hoses and lines.
 - Observe the completeness and tight fit of all connections when connecting the cables, hoses and lines.
-
- Connect the machine only to the specified voltage.
 - The operator must connect a cable to the potential equalisation before the first startup according to the terminal assignment plan.
 - Continuous connection of the protective conductor system must be available.
 - Observe the indications on the nameplate and in the electric circuit diagram.
 - Observe the local valid regulations and rules.
 - Please observe the manufacturer's specifications, see sub vendor documentation.
 - When connecting the connection lines open the aeration / manual shut-off valves and depressurise the connection lines.
 - Depressurise pneumatic system and protect against unauthorised restarting.



⚠ DANGER!

Danger of falling into the mixer tub.

- Life-threatening cut injuries.
- Keep off the mixer tub or the mixer rim.



⚠ CAUTION!

Danger of slipping and falling down from the climbing aids.

- Use suitable climbing aids when connecting the cables, hoses and lines.

Danger of slipping and falling down from the walking surface/platform!

- The crossing area from the cleaning platform to the floor must be made anti-slip by the operator.
- Always clean the walking surface of the cleaning platform thoroughly of water and grease.



⚠ CAUTION!

An insufficient aeration of the switchboxes and engines can overheat these parts.

- Install the machine so that a free air flow on the air grids is possible.



Information!

Rigid connected connection lines can lead to error messages of the load cells.

- The connection must be done via a flexible and removable line.

6.2 Electrical connection

6.2.1 Connecting the potential equalisation

- Connect the machine frames of the individual machines with protective conductor.
 - > Observe the terminal assignment plan.

6.2.2 Connecting the machine to the power supply



⚠ DANGER!

High electrical voltages can cause life-threatening electrical current-flows in the body and burns. The electrical connections are made

- according to the circuit diagram and the indications on the nameplate,
- according to the valid standards at the place of installation,
- to be done only by a qualified electrician.

Also with switched off main switch the heating in the control cabinet is live!



Information!

The valid regulations and rules for the connection according to EN 60204-1 must be observed. Following safety rules according to DIN VDE 0105 must be adhered to:

- disconnect,
- protect against restarting.
- Determine dead circuit.
- Lid neighbouring energized parts or lock.
- Short-circuit.

Connecting data according to circuit diagram/machine master card.

Use only delay-action fuses.

We recommend the use of larger wire-cross section for larger line lengths or with unfavourable voltage conditions.

The machine is switched by the factory in such a way that the rotation direction of the motors is correct. Nevertheless the rotation direction check should be carried out with the first start-up.

The machine has a phase sequence relay. The machine does not start in case of a wrong phase sequence. An error message is displayed at machines with control panel.

The machine is ready for operation.

- > The bin lid, manhole lid must be closed.

6.2.3 Rotation direction check

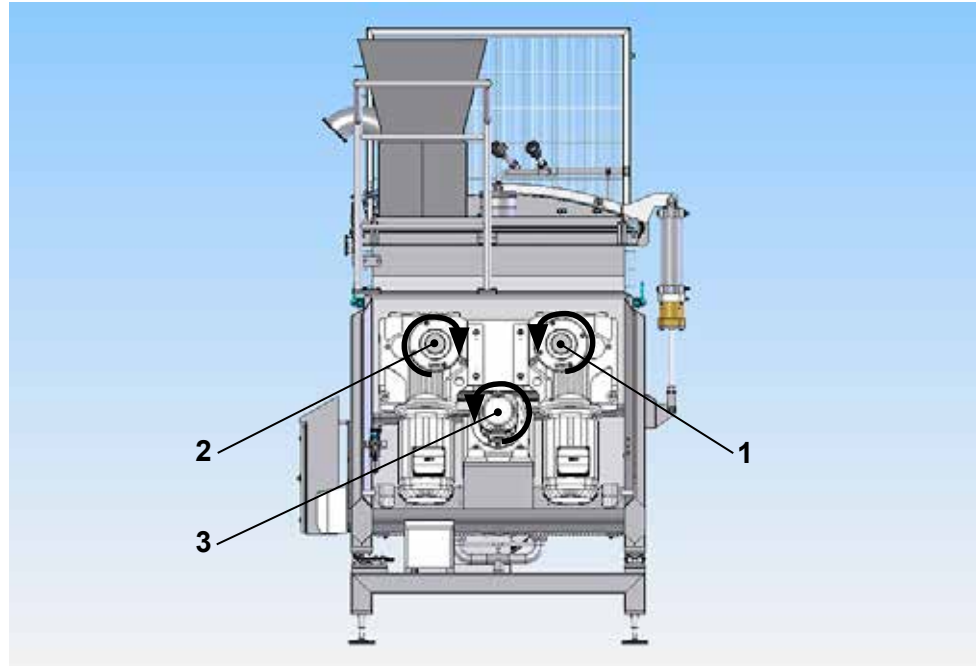

1. Switch on power supply.
2. The rotation direction of the mixing shafts 1+2 is to be checked with the corresponding operating buttons in the control panel.
3. The rotation direction of the discharge worm is to be checked with the corresponding operating buttons in the control panel.

Mixing shaft-1 to be seen from the drive -> RIGHT

Mixing shaft-2 to be seen from the drive -> LEFT

Shaft rotation direction discharging -> FORWARDS

Rotation direction of the mixing shafts for discharging -> as viewed from the drive to each other.

Direction of rotation of the discharge worm for discharging > as viewed from the drive to the left

6.3 Compressed-air connection



Information!

Observe pneumatic plan drawing no.: 288608.
 Observe the operating manual for the maintenance unit.
 Depressurise the pneumatic system in case of maintenance and repair work on the pneumatics and protect against unauthorised restarting.

With EMERGENCY-STOP and manual shut-off the pneumatic cylinders remain pressurised.
 ➤ Aerate compressed-air system during maintenance work.

The operator must provide the following auxiliary means and elements:

- Manual shut-off valve,
- compressor,
- compressed-air line up to the maintenance unit,
- connection lines to the machine with a flexible piece of hose.

The shut-off valve (4) is closed when pressing the EMERGENCY-STOP button, thus the entire machine is switched pressure-free.

Unlock EMERGENCY-STOP button, the shut-off valve (3) is switched on again and the pressure is slowly built up via the start-up unit (5).

With a working pressure of 4 bar the pressure switch (6) opens, control is operable again.



Item	Designation	Item	Designation
1	Connection	4	Switch-on/shut-off valve
2	Manual shut-off valve,	5	Start-up unit
3	Pressure gauge	6	Pressure switch

Compressed-air connection (1)	R 3/8"
Max. operating pressure	6 bar
Air consumption	120NI / double lift



Information!

The pneumatic lines must be checked at regular intervals for tightness and firm seat.

6.4 Water connection



Information!

Lock the water supply in case of maintenance and repair work on the water meter and protect against unauthorised restarting.

The operator must provide the following auxiliary means and elements:

- manual shut-off valve;
- pressure control-valve 4 bar;
- connection line to the machine with a flexible piece of hose.

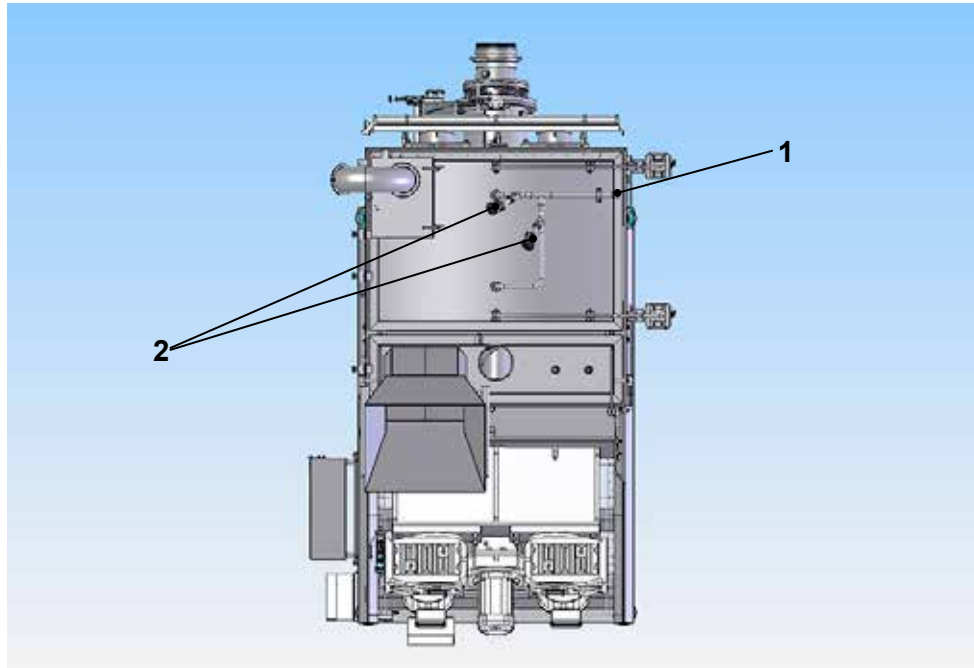

Pos.	Designation	Pos.	Designation
1	Connection	2	Shut-off valve
Connection		R 1 1/2"	
Recommended water pressure		max. 4 bar	
Max. operating temperature		90°C	

6.5 Steam connection



⚠ CAUTION!

The bin and its attachments strongly heat up when operating with hot steam.

- ⊕ Danger of being burnt through escape of hot steam at the aeration pipe.
 - Avoid touching the bin and the steam line.
- ⊕ Danger of being burnt through escape of hot steam at the condensate discharge.
 - Discharge the condensate outflow into a discharge channel.



Information!

Lock the steam supply in case of maintenance and repair work on the vaporisation and protect against unauthorised restarting.

Wait for the cool-down period of the steam line and the bowl.

The operator must provide the following auxiliary means and elements:

- manual shut-off valve;
- steam shut-off valve;
- Pressure control valve 4 bar;
- exhaust hood for steam suction;
- connection line to the machine with a flexible piece of hose.

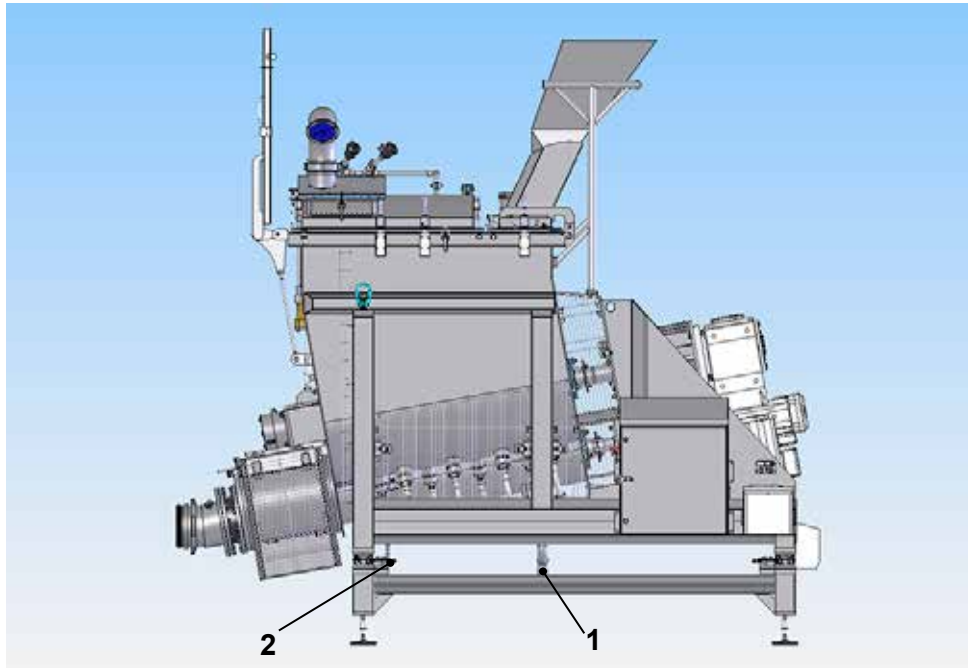

Pos.	Designation	Pos.	Designation
1	Connection	2	Condensate outflow

Steam connection	R 2" - 16 nozzles
Condensate outflow connection	R 1/2"
Recommended water pressure	max. 3.5 bar
Max. steam temperature	135°C

6.6 Manhole lid



⚠ CAUTION!

Danger of being burnt through hot steam/water when the manhole lid is opened.

- ⤷ Danger of being burnt through escape of hot steam/water.
- Switch off CIP before opening the manhole lid.

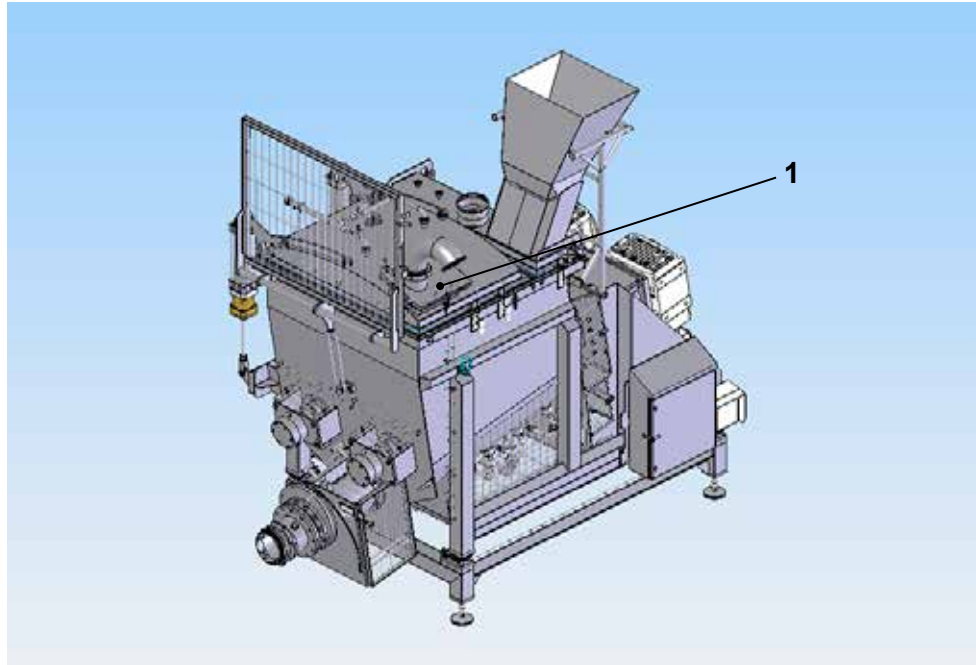

Item	Designation	Item	Designation
1	Manhole lid	2	

Small-sized components can be added manually when the manhole lid is opened.

6.7 Connection for admixtures



Information!

A rigid connected pipeline can lead to error messages of the load cells and to the destruction of the bin lid.

- The connection must be done via a flexible and removable line.

Required auxiliary means (on site).

The operator must provide the following auxiliary means and elements:

- Flexible piece of hose as connection line to the machine.

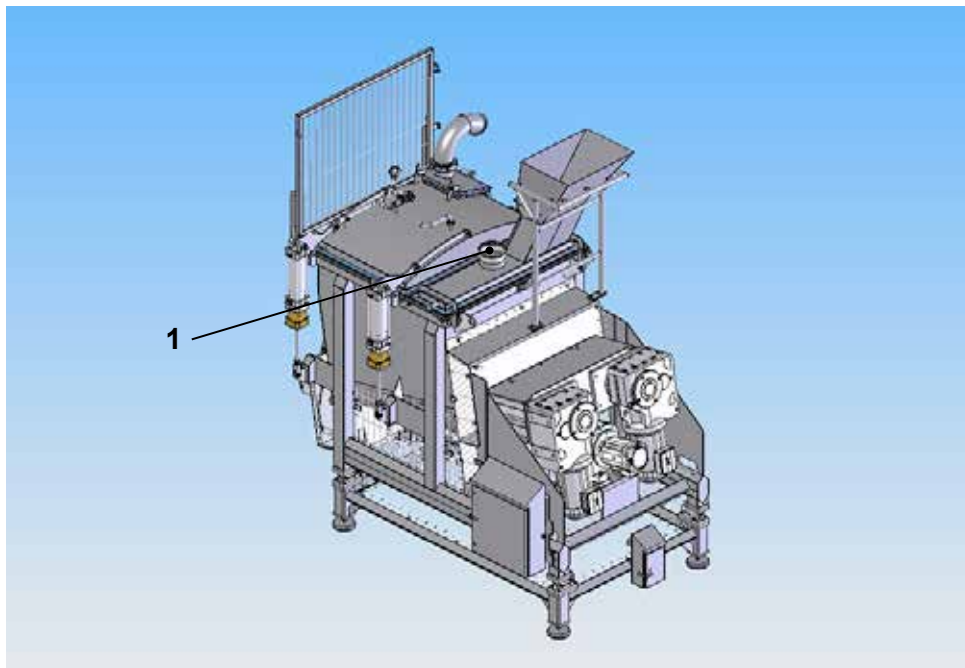

Pos.	Designation	Pos.	Designation
1	Connection DN 200	2	

7 Operation

The machine was supplied without a control unit.

The control is supplied by the customer.



Information!

The processing material may not freeze up in the mixer bin since it cause the damage and destruction of the drives.

The processing material is supplied to the bin with a temperature of -18°C.

The control must be programmed by the customer so that the interval of the mixing shaft amounts to at least 60 sec.

Under no circumstances may the processing material freeze in the bin.

8 Preparing for operation

8.1 Safety instruction for the commissioning



⚠ DANGER!

The machine was supplied without switchbox and control. Switchbox and control must be installed by the customer according to the customary prescriptions and regulations before the first start-up.

- First start-up of the machine only by specially instructed personnel.
- The assembly instruction must be read by the specialists/operator responsible before the first start-up and must be continuously available at the place of use of the machine or plant.
- The local safety- and accident prevention rules must be adhered to for the commissioning of the machine.

Make yourself sufficiently familiar with

- the operation and control elements of the machine;
- the equipment of the machine;
- the working method of the machine;
- the local environment of the machine;
- the safety devices of the machine;
- the measures for an emergency.

8.2 Before starting up the machine



⚠ DANGER!

After switching on the machine operates in the automatic operation via the control.

- Check and ensure that all safety devices are fitted and work properly.
- Check the machine for visible damages; eliminate detected defects immediately or report them to a supervisor.
- The machine may be operated only in a technical proper condition.
- Check and ensure that only authorised person stay in the working area of the machine and that no other persons are endangered through the start-up of the machine.
- Observe the audible and optical signals, (if any.)



⚠ CAUTION!

Danger of slipping and falling down from the walking surface/platform!

- Always clean the walking surface of the cleaning platform thoroughly of water and grease.



Information!

Check whether the breather valve/vent plug on the gear is activated.
See Chap. 11.2.4

1. Clean all parts coming into contact with foodstuffs before starting up the first time (see Chapter 10.)
2. All safety- and protective devices have to be checked on their functioning.
3. Check all machine functions.
4. Check all supply connections (see Chapter 6.)
5. Clean entire machine (see Chapter 10.)

6. Instruct operating personnel.

8.3 Training

Carry out a complete training/instruction of the operating- and maintenance personnel before starting up the machine for the first time.

8.4 Initial startup



Information!

Frozen product may not be stored in the mixer bin over a longer period since the product can freeze to a solid mass and lead to the damage of the shafts and the drive when restarting.

The mixer bin may be operated with 1000 litres product.

This incomplete machine may only be put into operation if it has been determined that the machine, into which this incomplete machine/system is to be installed, corresponds to the machine directive EG 2006/42/EG.

The machine is integrated into the Production Line - Pet Food no.: 80236.

The machine has been set by the factory, afterwards the machine can be checked for proper function after implemented connection and a test-run can be carried out after connection is made and completion of all prework.

1. Switch on power supply.
2. Switch on mixing shafts.

8.5 Acceptance

A handover and acceptance record must be created for the machine.

The handover and acceptance record contains the efficiency of the safety devices; the machine functions checked and the names of the persons who received an instruction on the machine.

The handover and acceptance record, as well as the test record, must be signed by the safety inspector and the operator.

The acceptance records must be returned to the factory and filed in the machine documents.

9 Normal operation

9.1 Safety information for the normal operation



⚠ DANGER!

The machine was supplied without switchbox and control. Switchbox and control must be installed by the customer according to the customary prescriptions and regulations before the first start-up.

- The assembly instruction must be read by the specialists/operator responsible before the first start-up and must be continuously available at the place of use of the machine or plant.
- The working rules for safe operation must be stated.
- The machine should only be operated by trained operators. Operators should be provided with regular retraining.
- The local safety- and accident prevention rules must be adhered to for the operation of the machine.
- The machine may be operated only in a technical proper condition.
- The safety devices may not be removed or put out of operation.
- Only authorised persons may stay in the working area of the machine during the operation.
- The operating personnel may stay in the working area of the machine during the operation of the machine.
- Process only products suitable for the machine.



⚠ DANGER!

Danger of falling into the mixer tub.

- ☞ Danger to life and limb. Severe injuries up to death.
- Always keep off the mixer tub or the mixer rim.



⚠ DANGER!

The safety devices are used for the protection of the staff and machine of injuries or damages.

- The main switch resp. repair switches must be freely accessible at any time.
- The EMERGENCY-STOP switches must be freely accessible at any time.
- Only operate the machine if the safety switches are in working order.
- All safety- and protective devices must be checked on their functioning before starting with work. The safety switches must be checked with the utmost caution and care (see Chapter Maintenance/Inspection.)



⚠ CAUTION!

The bin and its attachments strongly heat up when operating with hot steam.

- Avoid touching the bin and the steam lines.

Danger of slipping and falling down from the walking surface/platform.

- Always clean the walking surface of the cleaning platform thoroughly of water and grease.
- It must be observed that the workstation of the operator is kept clear of objects which could represent a danger.

9.2 Feeding

9.2.1 Feeding via a Screw Conveyor



⚠ DANGER!

Danger through crushing.

- ➔ Danger to life and limb. Severe injuries up to death.
- Never reach into the inlet.



Information!

There may be no fixed connections between the outlet of the upstream connected machine and the mixer lid since this causes error messages of the weighing unit.

- Ensure that the upstream connected machine and the feeding opening at the mixer lid do not touch.

Observe Installation Plan No.: 18-106-....

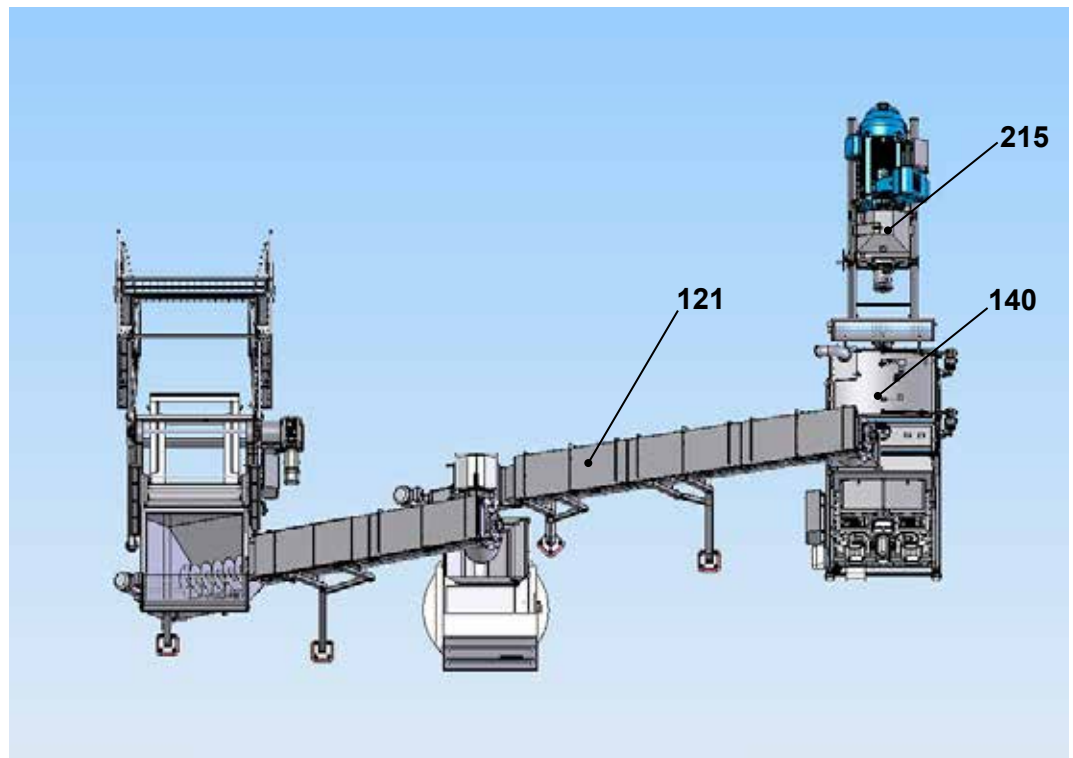

Pos.	Designation	Pos.	Designation
121	Screw conveyor with serial no.: 15458	215	Emulsifier serial no.: 36072
140	Mixer 1000 with serial no.: 15459		

The mixer 1000 (140) with the serial no.: 15459 is fed via the screw conveyor (121) with the serial no.: 15458.

Refer to the assembly instruction of the Screw conveyor (121) with the serial no.: 15458.

9.3 Discharge

9.3.1 Discharge into emulsifier



⚠ DANGER!

Danger through crushing.

- Danger to life and limb. Severe injuries up to death.
- Never reach into the outlet.

The mixer may be operated only with firmly connected emulsifier.



Information!

Error messages of the load cells can occur through the transfer of vibrations between mixer and emulsifier.

- Ensure that the rubber expansion joint is installed correctly.
- **Rigid connected pipelines can lead to error messages of the load cells and to the destruction of the bin lid.**
- The connection must be done via a flexible and removable line.

When discharging the mixer into another machine make sure that the outlet range is secured so that it corresponds to the valid safety regulations.

Observe Installation Plan No.: 18-106-....

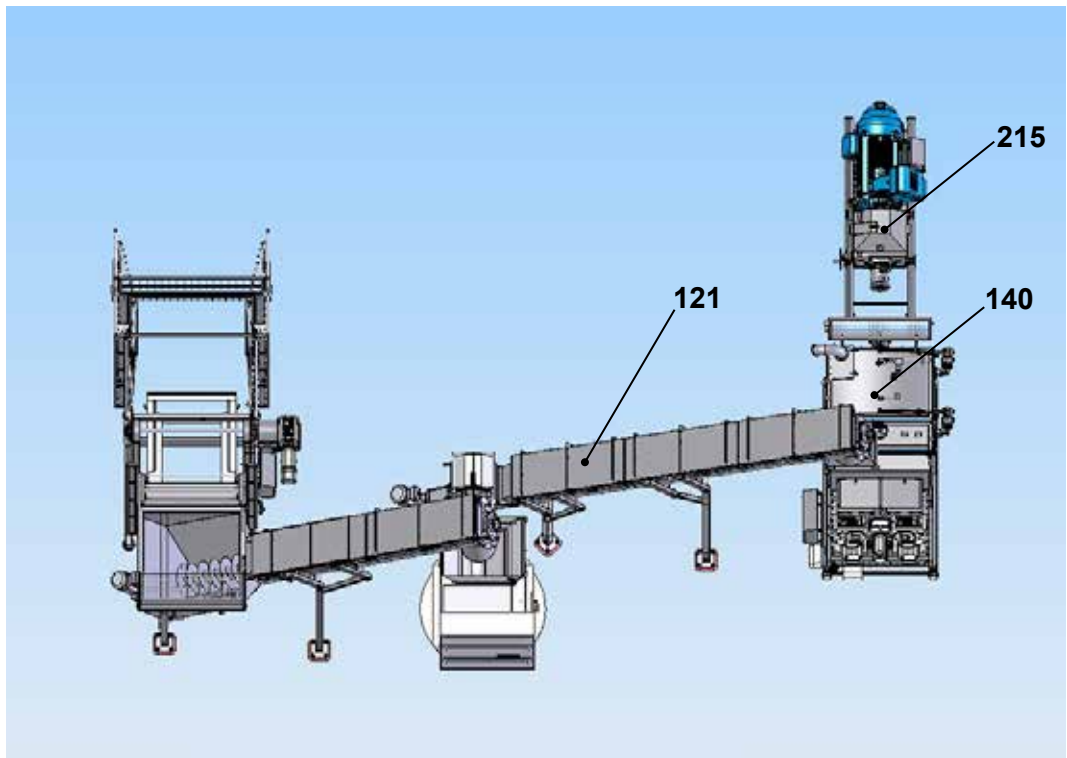

Pos.	Designation	Pos.	Designation
121	Screw conveyor with serial no.: 15458	215	Emulsifier serial no.: 36072
140	Mixer 1000 with serial no.: 15459		

The mixer 1000 (140) is intended for the discharge of the product into a KS emulsifier (215) with serial no.: 36072.

Observe sub vendor documentation of KS emulsifier (215) with serial no.: 36072

9.4 Switch machine on and off

9.4.1 Switch on machine

Requirements

1. Operating voltage must lie adjacent.
2. All safety devices must be brought into an operable state.
3. Rotation direction of the drive motors must correspond to the marking on the machine,
4. product must be fed in,

Procedure

1. Switch on power supply.
2. Feed product.
 - > If an external feeding device is installed, then switch it on.
3. Start pogramm

9.4.2 Switch off machine in the emergency case

1. Press EMERGENCY-STOP button.
 - > Motors are switched off and can no longer be started.
2. Unlock EMERGENCY-STOP button. Pull out the button cap for to do this.
 - > Motors can be switched on and started.

9.5 Troubleshooting and remedy



Information!

The machine was tested thoroughly before delivery. If the machine is used according to the order data as well as treated according to our lubrication- and maintenance instructions, then a satisfactory operation is to be expected over a longer period of time.

9.5.1 General safety information

Observe the safety information regarding the repair work see Chapter 11.

9.5.2 Requirements for the operating personnel

Qualification and competence of the personnel in respect of trouble shooting and fault-clearance (see Chapter 4.10.)

An instruction of the operator on the machine is carried out for work which the user may do. All other faults must be remedied by authorised personnel. (See Chapter 4.10.)

9.5.3 Table of faults

In the specified table type, the possible causes and remedy of possible faults are listed.

A fault can have various causes and a cause can lead to various faults.

Fault type	Possible cause	Remedy of the fault	through
Machine cannot be started.	Power supply is not switched on.	Switch on power supply.	B
	Connecting cable is connected wrongly.	Carry out phase sequence.	E
	EMERGENCY-STOP button is activated.	Unlock EMERGENCY-STOP button.	B

Fault type	Possible cause	Remedy of the fault	through
Mixing/discharging can not be started.	Mixer lid, feeding lid are opened.	Close mixer lid, feeding lid.	B
	Safety switch is loose/defective.	Check safety switch.	E
Mixer lid can not be opened.	Compressed-air connection is defective.	Check the compressed-air connection.	Q
Product leaks out at the cleaning flap.	Rubber seal is defective.	Check rubber seal.	Q
Product leaks out at the stuffing box.	The sealing set is not tightened correctly.	Tighten sealing set.	Q
	Sealing set is worn.	Replace sealing profile.	Q
	Bushing has shrunk.	Replace bushing.	Q
Bin lid cannot be opened.	Mixing shafts are switched on.	Switch off mixing shafts.	B
	Vaporisation or water supply are not switched on.	Switch off vaporisation or water supply.	B
	Safety switch is loose/defective.	Check safety switch.	E
	Compressed-air connection is defective.	Check the compressed-air connection.	Q
Bin lid cannot be closed.	Safety switch is loose/defective.	Check safety switch.	E
	Compressed-air connection is defective.	Compressed-air connection is defective.	Q
	Safety bolts of the lid locking are extended.	Retract safety bolts of the lid locking.	B
Mixing shafts touch the mixer bin.	Mixing shaft is bent.	Check and align mixing shaft.	Q
	Bearings are loose.	Realign bearings and screw them on.	Q
	Bearings are defective.	Replace bearings.	Q
Discharge worm touches the mixer bin.	Screw thread is bent.	Check and align screw thread.	Q
	Bearings are loose.	Realign bearings and screw them on.	Q
	Bearings are defective.	Replace bearings.	Q
Bearing is getting hot.	There is no more lubrication existing.	Check lubrication lines, keep to the lubrication interval.	Q
	Bearing is defective.	Replace bearing.	Q
Sealing of the stuffing box is getting hot.	Screws are tightened too firmly.	Loosen screws and readjust sealing.	Q
Drive sounds are very loud.	Gear/motor bearing is defective.	Replace gear/motor bearing.	Q
	Fastenings on the gear are loose.	Readjust fastenings on the gear.	Q
	Bearings are loose.	Tighten the bearings.	Q
Vaporisation, water supply cannot be started.	Bin lid is open.	Close bin lid.	B
Drive cranks.	Spring is not tightened correctly.	Readjust spring.	Q
Motor hums and has a high power consumption.	Look at the sub vendor documentation on the SEW motors.		Q

Fault type	Possible cause	Remedy of the fault	through
Faults on the drive gear.	Look at the sub vendor documentation on the SEW gears.		Q

B = operator of the machine

E = electrician

Q = qualified specialist

10 Cleaning

10.1 General safety information



⚠ CAUTION!

Working with steam or high-pressure cleaner.

- ☞ Injuries because of spraying debris.
- Wear goggles when working with low-pressure cleaners.

Damage at the operating unit is possible.

- Clean the foil keyboard only with a damp cloth!
- Do not clean the operating surface at the control panel with high pressure.

Do not spray the drive chains with high-pressure/low-pressure cleaner.

10.2 Cleaning instructions



Information!

Do not clean console terminals, control boards and electrical components directly with steam and/or high-pressure. Thus an excessive condensation in the housings is caused which could lead to failure. Water could also be pushed past the housing seals which could also lead to failure.

Dried-on dirt makes cleaning difficult. We therefore recommend keeping the time between the end-production until the start-cleaning as short as possible.

The safety data sheets and product data sheets of the cleaning and disinfection agents must be observed.

- Clean the machine after the end of work, at least once a day.
- Use detergents approved for the foodstuff sector.
 - > Please consult the manufacturers of the detergents.
 - > Other detergents than the indicated can be also used.
- Only use detergents which do not corrode metal, rubber or plastic parts.
- Depending on the application range of the machine, other cleaning methods than those described may be used.
- An insufficient cleaning of the machine can cause impurities of the product.

10.3 Cleaning process manual

1. Shut off power to the machine and secure against unauthorised restart.
2. Open bin lid and protective grid.



⚠ DANGER!

Danger of falling into the mixer tub.

- ☞ Danger to life and limb. Severe injuries up to death.
- Always keep off the mixer tub or the mixer rim.

3. Remove coarse dirt.
 - > Clean bin, bin tub and outlet range e.g. with a high-/low-pressure cleaner.
4. Pre-rinse carefully with hot water (60°C.)
5. Check for visual cleanliness.

6. Foam up with an appropriate detergent.
7. Wait for stipulated time for to take effect.
8. Rinse with warm water (60°C) from top to bottom.
9. Check critical points and problem areas.
10. Disinfect before starting production.
11. Wait for stipulated time for to take effect.
12. Rinse with drinking water.

10.4 Cleaning schedule, manual



Information!

The specified cleaning schedule was derived in co-operation with the Henkel Hygiene company. The illustrated cleaning and disinfection recommendation was created in cooperation with the ECOLAB company. Due to the variety of different materials and processing procedures, the information mentioned below can be considered only as indicative and not binding.

Working steps	Cleaning agent	Procedure	Devices	Notes
Course cleaning. Removal of product rests if necessary after disassembly of the small parts.		By hand, mechanically.	Filler, scraper.	Start immediately end of production.
Disassembly and cleaning of the small parts.	1% ECOLAB P3-topax 99.	After thoroughly pre-rinse with water max. 60°, acc. to fat softening point foam or manually, for approx. 15 min.	Low-pressure foaming device, brush, tub.	Lay the parts on the grid.
Pre-rinse thoroughly.	Drinking water.	Low-pressure up to 30 bar. Temp. 60° acc. to fat softening point.	Low-pressure device, water-hose.	All small parts included.
Check for visual cleanliness.		Visual control, take care with problematic zones.		
Acid cleaning acc. to requirement instead of alkaline cleaning.	2-5% ECOLAB P3-topax 19 chlorine-free P3-topax 66.	Foam or manual, approx. 15 min time of effect.	Low-pressure foaming device, brush, tub.	Daily, also the small parts.
Rinse.	Drinking water.	Low-pressure up to 30 bar. Temp. 50-60°C.	Low-pressure device, water-hose.	Entire system and small parts.
Disinfect.	1% ECOLAB P3-topax 91.	Spray, foam time of effect according to product data sheet.		Entire system and small parts. After conclusion of all the cleaning measures to be done in the room.
Rinse.	Drinking water.	Low-pressure up to 30 bar.	Low-pressure device, water-hose.	Rinse process from top to bottom.
Dry				

Working steps	Cleaning agent	Procedure	Devices	Notes
Servicing.	E.g. food grade servicing oil.	Spray.	Spray-gun.	

11 Maintenance

11.1 Safety information for the maintenance

11.1.1 Mechanical dangers



⚠ DANGER!

Danger of falling into the mixer tub.

- Life-threatening cut injuries.
- Keep off the mixer tub or the mixer rim.

Danger due to the mass, shape and weight of the machine components.

- The operator must provide for the necessary auxiliary aids such as crane, forklift, hoists etc.
- Special caution must be given during all maintenance/inspection work to all machine components due to their heavy weight and non-ergonomic installation locations.
- Wear personal protective-clothing such as a protective helmet, safety shoes, goggles and gloves during maintenance and inspection work on the machine.



⚠ CAUTION!

Drive clutch.

- Danger of the lower limbs being crushed by parts falling down during maintenance work.

Mixer lid, manhole lid.

- Danger of the fingers/hands being crushed when closing the lids.

Severe injuries to people and damage to property can be caused through faulty screw tightening torques.

- Observe the table of the tightening torques in the Appendix.

Severe damage can be caused at the machine if other load lifting appliances will be used than the indicated ones.

- Only use approved and sufficiently dimensioned load lifting appliances.

Danger of slipping and falling down from the climbing aids.

- Use suitable climbing aids while doing repair work.

Danger of slipping and falling down from the walking surface/platform!

- Always clean the walking surface of the cleaning platform thoroughly of water and grease.

Danger of slipping on spilled oil on the floor when changing the oil.

- Remove oil immediately, seal the leaky points.



⚠ CAUTION!

Working with steam or low-pressure cleaner.

- Injuries because of spraying debris.
- Wear goggles when working with low-pressure cleaners.

11.1.2 Electrical dangers



⚠ DANGER!

Injury from cables.

Touching of live sections.

Injection of water into the opened control cabinet resp. terminal box.

- ⌚ Electric shock 230/400V caused by electrical voltage.
- Switch voltage supply always off and protect against unauthorised restarting during maintenance and repair work.

Voltage-storage components installed (frequency converter).

- ⌚ Dangerous residual voltage.
- Pay attention to discharging time.
- Check clamping points on residual voltage.
- All works on the electrical equipments of the plant may be carried out in principle only by trained electricians.

11.1.3 Chemical dangers



⚠ CAUTION!

Using detergents.

- ⌚ Danger through contact with or inhalation of dangerous liquids, gases, hazes, steams or dust.
- Observe the safety regulations when handling detergents!
- Wear personal protective clothing / gloves, goggles, protective suits.
- Observe safety data sheet of the detergent manufacturer.

11.1.4 Thermal dangers



⚠ CAUTION!

Vaporisation.

The bin and its attachments strongly heat up when operating with hot steam.

- ⌚ Burns through escape of hot steam.
- ⌚ Burns when touching the steam lines.
- ⌚ Burns through escape of hot cleaning water and detergents.
- Check the pipeline screwing regularly for tightness.
- Wait for the cool down.
- Always wear heat-resistant protective gloves when performing maintenance- and repair work.
- Avoid touching the pipelines.
- Avoid touching the bin and the steam line.

Oil change.

- ⌚ Danger of being burnt by hot oil!
- Wait for the gear to cool down.

11.2 Inspection and maintenance



Information!

In order to ensure a reliable operation of the machine, the prescribed maintenance and inspection works have to be executed in time.
 We offer low-cost maintenance contracts via our service department. Our qualified installation staff perform then the maintenance work speedily with competence and expert knowledge.
 The periods for the regular inspection are monitored by us.



Information!

Use only original parts of KS.
 In order to process your spare parts order quickly and correctly, you should provide the following details with each order:
 Machine No.: see Assembly instruction/machine master data
 Type designation: see Assembly instruction/machine master data
 Spare part No. with designation Drawing of construction unit/machine master data



Information!

Use only lubricants approved for the foodstuff sector according to USDA-H1!

11.2.1 Maintenance- and inspection schedule

Regular checking of the protective conductor system according to EN 60204-1 must be carried out and documented.

Continuous connection of the protective conductor system must be available. Regular checking of the protective conductor system must be carried out and documented.

Pneumatics- The maintenance unit must be checked at regular intervals and the condensed water that arises must be drained off.



Information!

Observe the working hour meter in the switchbox!
 A complete inspection has to be carried out after 100 operating hours.

Work to be done	Chapter	40 hrs	160 hrs	500 hrs	2000 hrs	Remark
Grease machine	11.2.2	x				
Check drive gear and motor	11.2.5			x		A
Oil change of drive gear	11.2.5				x	A
Check/readjust seals	11.2.6			x		
Check flange sleeve	11.2.7			x		
Replace drive gear of the mixing shafts	11.3.1				x	B
Replace coupler and spring on the mixing shaft drive	11.3.2				x	B
Replace drive gear of the discharge worm	11.3.3				x	B
Replace coupler and spring on the mixing shaft drive	11.3.4				x	B
Check mixing shaft bearing at the outlet	11.3.5			x		
Replace mixing shaft bearing at the outlet	11.3.5				x	B
Check bearing on the drive of the mixing shaft/ discharge worm	11.3.6			x		B
Replace bearing on the drive of the mixing shaft/ discharge worm	11.3.6				x	B

Work to be done	Chapter	40 hrs	160 hrs	500 hrs	2000 hrs	Remark
Replace seals/sealing material of stuffing box	11.3.7				x	B
Replace flange sleeve	11.3.8				x	X
Check rubber seal of the mixer bin	11.3.9			x		
Replace rubber seal of mixer bin	11.3.9				x	B
Check rubber seal of the cleaning flap	11.3.10			x		
Replace rubber seal of the cleaning flap	11.3.10				x	B
Check pneumatic system	6.3			x		C
Replace pneumatic lines	6.3					B
Check fastening bolts	all		x			
Check screw connections of the pipelines for tightness and firm seat	all		x			

A: Observe separate operating manual of the SEW drive gear.

B: is according to condition and degree of wear of the wearing parts. Replace only if necessary.

C: Observe separate operating manual of the vacuum pump.

For further information see the manufacturer's specifications in the Appendix.

* Details with one-shift operation.

* Number and size of the wear parts to be used can be obtained from the machine master data.

11.2.2 Lubrication points overview

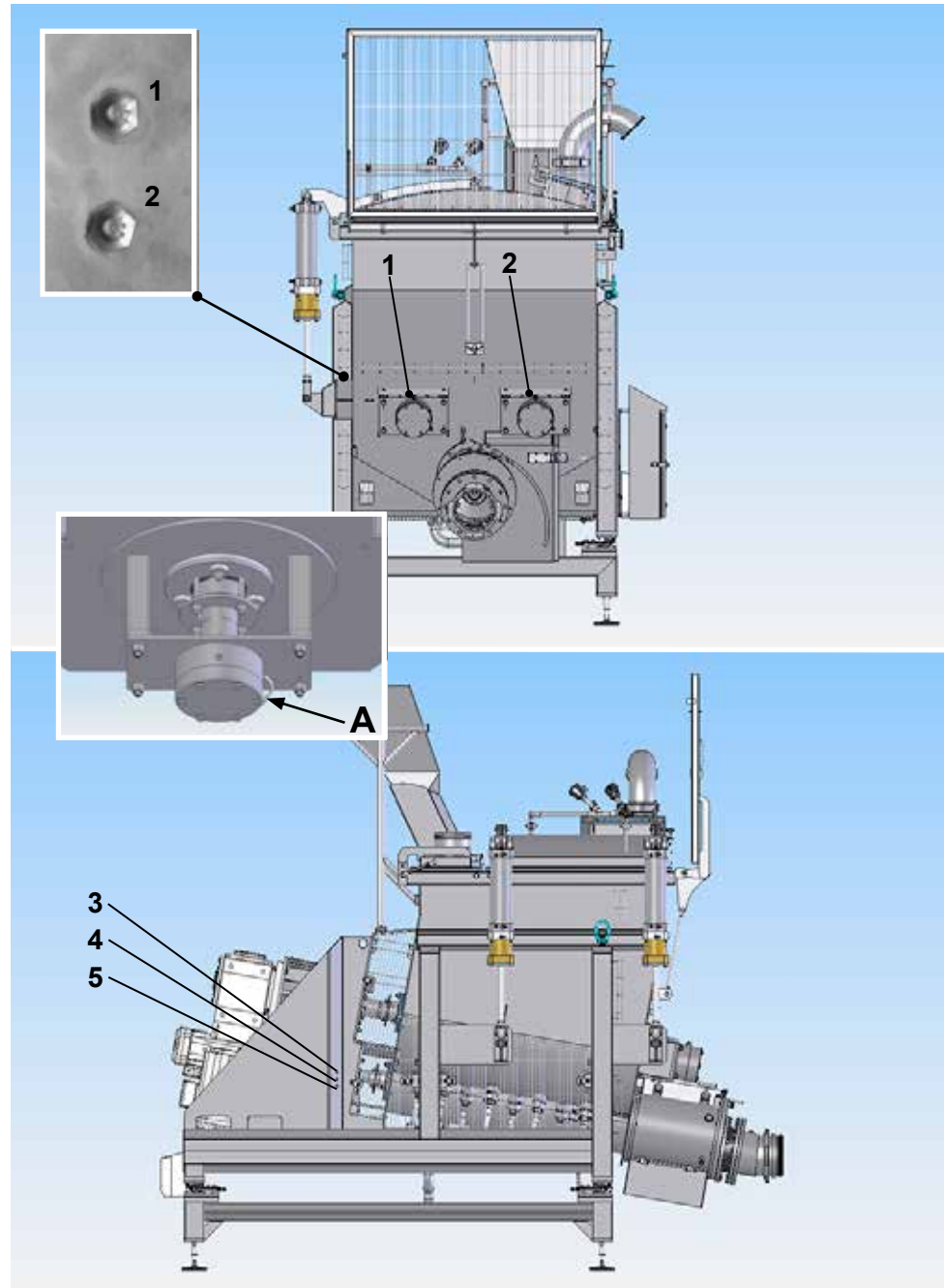

Pos.	Lubrication point	Operating hours	Quantity	Stroke	Lubricant
1	Bearing of mixing shaft-1 outlet side	160h	8g	4x	Food-grade grease (FG)
2	Bearing of mixing shaft-2 outlet side	160h	8g	4x	Food-grade grease (FG)
3	Bearing of mixing shaft-1 drive side	160h	8g	4x	Food-grade grease (FG)
4	Bearing of mixing shaft-2 outlet side	160h	8g	4x	Food-grade grease (FG)
5	Bearing/discharge worm	160h	8g	4x	Food-grade grease (FG)

2 g corresponds to 1 lift of a hand-lever grease-gun.

Factory-made filling

Bearing grease SHELL CASSIDA RLS 2

11.2.3 Lubrication plan



Information!

Before greasing - thoroughly clean lubricating nipples!
* Pump must be filled sufficiently with lubricants.

If the machine has been taken out of operation for a longer period of time, all bearing points must be greased again before starting up.

The exceeding grease is drained outward via the overflow line (A).
The overflow line may not be closed.
Grease overflow hose (A) max. length 1000 mm - \varnothing 12 mm.

11.2.4 Gear unit venting



Information!

Activating the breather valve

Check whether the breather valve is activated. If the breather valve has not been activated, you must remove the transportation protection device from the breather valve before starting up the gear unit.

Look at the sub vendor documentation of SEW gear.

1. Breather valve with transportation protection device
2. Remove transport fixture
3. Activated breather valve

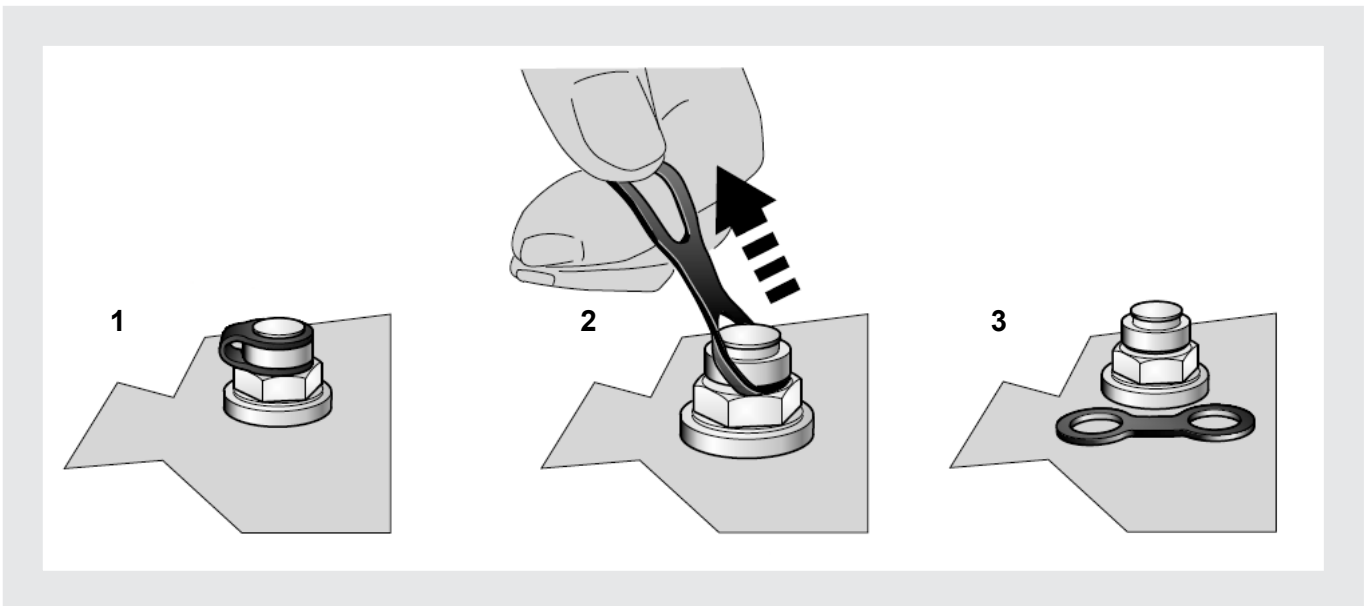

11.2.5 Instruction for gear oil change: mixing shaft drive



Information!

Please look at the inspection/maintenance prescription of the company SEW for the oil change, see sub vendor documentation. (* Oil change after 8000h max every 3 years)
 Please observe all corresponding valid safety regulations for the handling with lubricants when changing the oil.

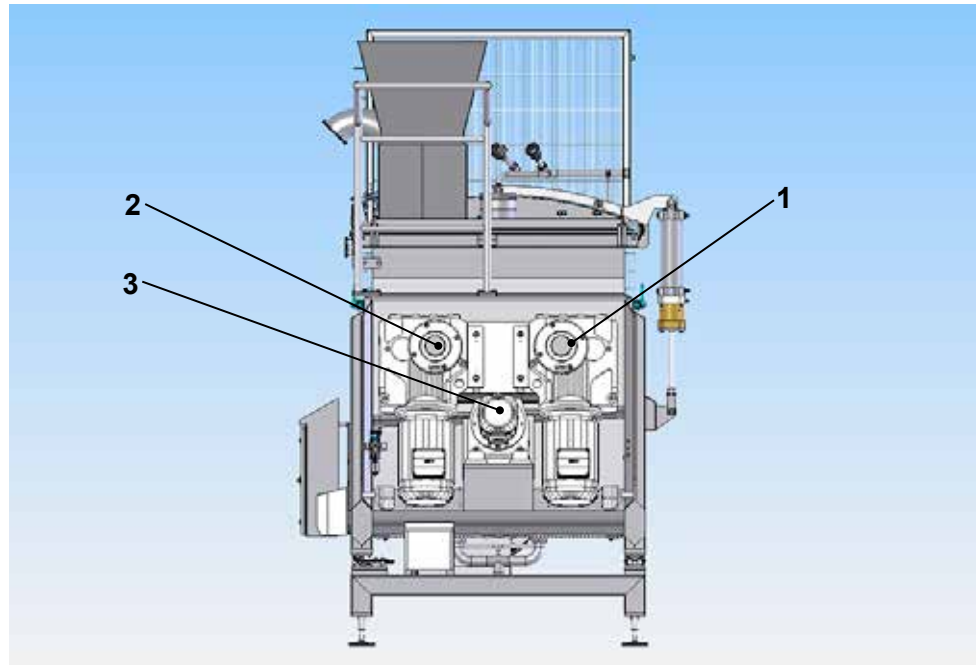

Pos.	Lubrication point	Operating hours	Quantity	Lubricant
6	Drive gear mixing shaft 1	8000h	21Ltr.	Food grade oil (FO)
7	Drive gear mixing shaft 2	8000h	21Ltr.	Food grade oil (FO)
8	Drive gear mixing shaft 1	8000h	5,6Ltr.	Food grade oil (FO)

Drive gear of mixing shaft drive KAZ 107

Motor model	M2A / M2B
Oil quantity	21L
Factory-made filling	Optimol OBTILEB GT 460 (HC-460 NSF-H1)

Drive gear of discharge worm R 97

Motor model	M1-M4 10°
Oil quantity	5,6 L
Factory-made filling	Optimol OBTILEB GT 460 (HC-460 NSF-H1)

11.2.6 Check/readjust seals

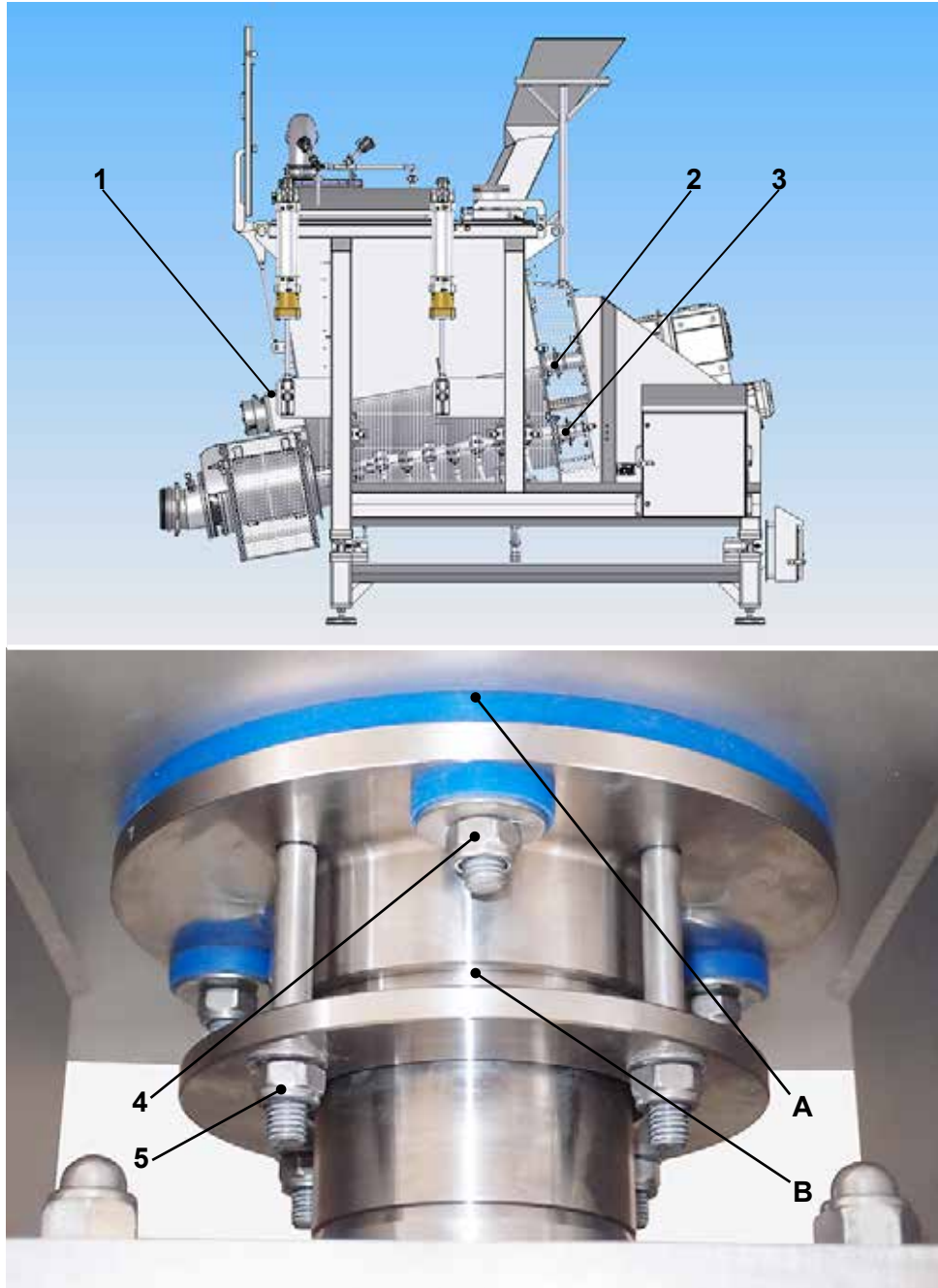

The mixing shafts and the discharge worm are equipped with readjustable seals (1,2,3).
Product- or liquid escape on the sealing spot (A) of the mixer bin:



⚠ CAUTION!

Danger of being burnt on hot machine components.

1. Readjust the seals
 - > Tighten all 3 nuts (4) one 1/2 rotation.
- With product escape on the sealing spot (B):
1. Readjust the seals.
 - > Tighten all 4 nuts (5) one 1/2 rotation.

If the sealing cannot be re-tightened any longer, then the sealing profile must be replaced (see chapter 11.3.7.)

11.2.7 Check flange sleeve of discharge worm

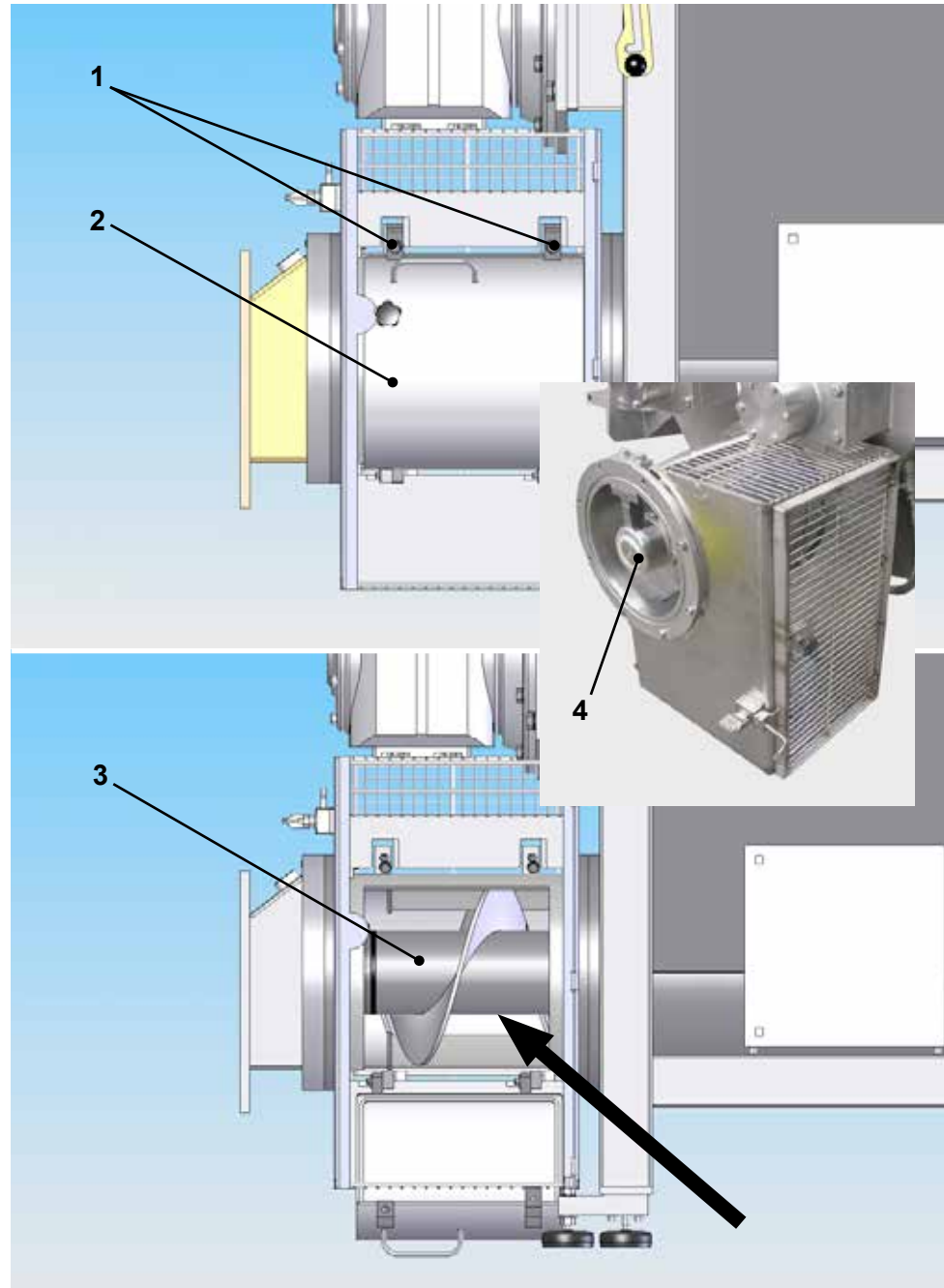

Check bearing fit of the discharge worm at regular intervals (every 160 h).

1. Shut off power to the machine and secure against unauthorised restart.
2. Open protective grid.
3. Loosen both fastening screws (1) at the cleaning flap (2) and unscrew them.
4. Swivel up cleaning flap (2).
5. Put a squared timber below the discharge worm (3) and try to raise the discharge worm carefully. If the discharge worm can be raised easily then the flanged sleeve (4) must be replaced.
6. Replace flange sleeve, (observe Chapter 11.3.8)

11.3 Repair

11.3.1 Replace gear of the mixing shaft drive

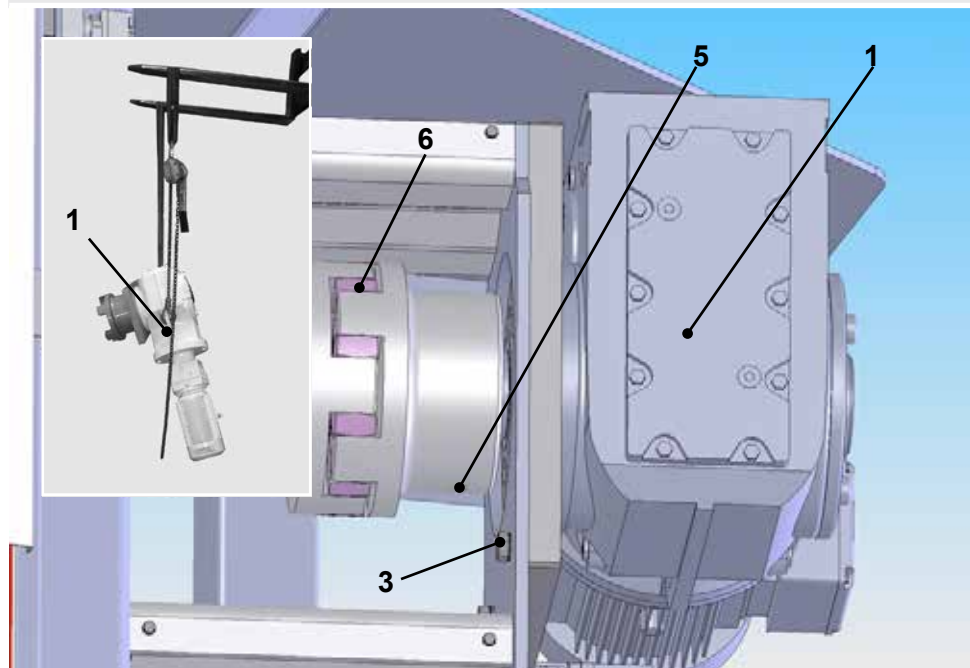
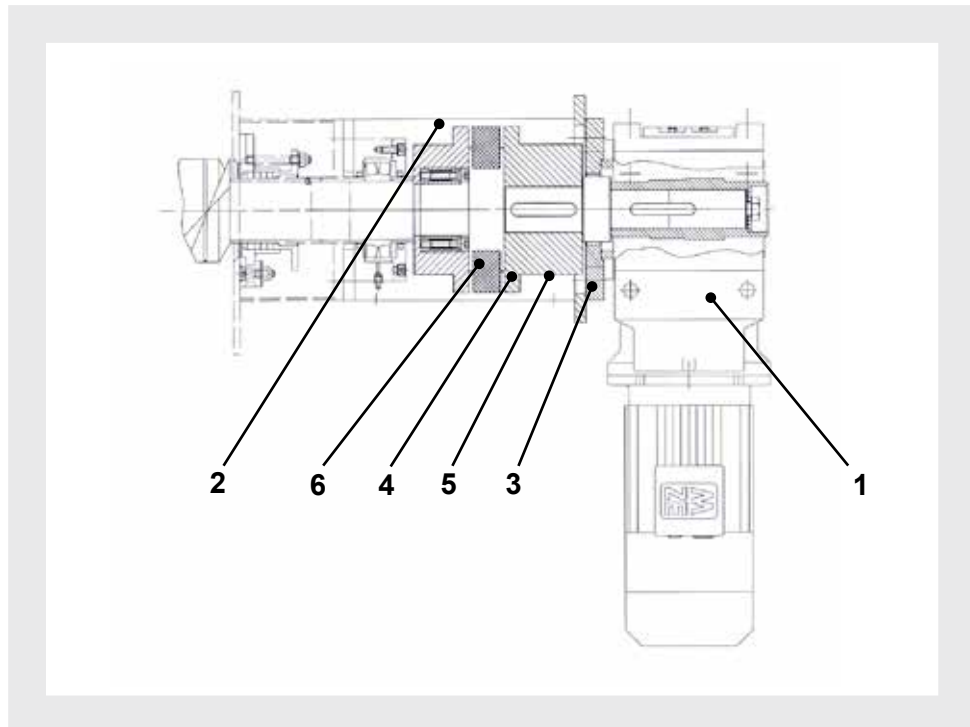

Drive drawing no.: 2-00101003

Pos.	Designation	Pos.	Designation
1	Gear	4	Coupler flange
2	Contact guard plate	5	Grub screw
3	Hexagonal bolt	6	Gear rim

Disassembly



⚠ CAUTION!

Danger of fingers/hands being crushed, caught.
Danger of being injured by assembly parts falling down.

1. Shut off power to the machine and secure against unauthorised restart.
2. Have the connecting cable be disconnected by an **authorised** electrician.
3. Attach gear (1) with a carrying rope to the crane and protect against falling down.
 - > (Observe weight of the gear with coupler approx. 250 kg.)
4. Disassemble contact guard plate on top and bottom.
5. Loosen hexagonal bolt (3) and unscrew them. Pull off mitre gear (1) to the rear together with the coupler flange (4) and place it onto an assembly table.
6. Unscrew grub screws (5) and pull coupling flange (4) from the motor shaft.
7. Clean coupling flange (4) and motor shaft thoroughly and grease them.
8. Check gear rim (6), replace if necessary.

Assembly



⚠ CAUTION!

Danger of fingers/hands being crushed, caught.
Danger of being injured by assembly parts falling down.

1. Attach coupling flange (4) to the motor shaft, and secure it with the grub screw (5).
2. Attach gear (1) with a transport rope and a pulley block.
3. Reinsert gear (1) with crane into the reception flange, thereby take care of the position of the gear rim (6).
4. Reinsert hexagonal bolt (3) and screw them on.
5. Have the connecting cable be connected by an authorised electrician.
6. Reinstall contact guard plate at top and bottom (2).
7. Carry out a test run.

11.3.2 Replace coupler and spring on the mixing shafts

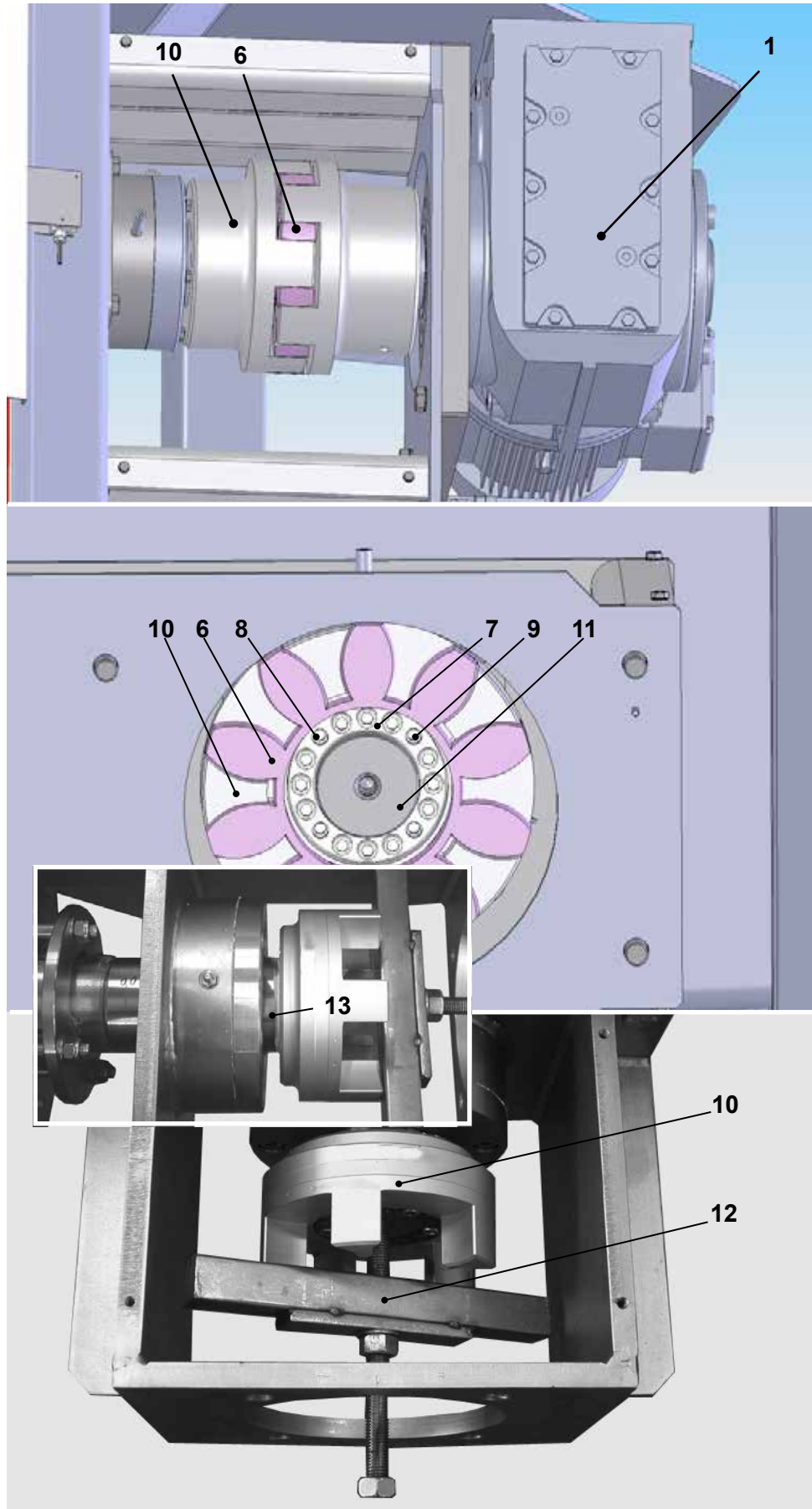

Drive drawing no.: 2-00101003

Pos.	Designation	Pos.	Designation
6	Gear rim	10	Shaft
7	Spring	11	Clamp
		12	Clamping nut
8	Head screw	13	Straining screw
9	Jack drills	14	Bushing

Disassembly



⚠ CAUTION!

Danger of fingers/hands being crushed, caught.
Danger of being injured by assembly parts falling down.

1. Shut off power to the machine and secure against unauthorised restart.
2. Removing gear (see Chapter 11.3....).
3. Remove gear rim (6).
4. Loosen spring (7).
5. Loosen all head screws (8) evenly and crosswise in several steps.
6. Screw in evenly head screws (8) into the jack drills (9).
 - > Spring is slackened.
7. Pull spring (7) together with coupler flange shaft (10) from the shaft (11).
8. Only remove head screws (8) from the jack drills (9) when the spring is dismantled completely.



Information!

After each loosening of the spring or when reinstalling the chain wheel, a new spring must be used in any case.
 All contact surfaces, including thread and connecting surface of the clamping bolts, must be clean and provided with an oil film.
 Mount shaft, hub and spring after oiling them first.
 Do not use any Molykote (type of grease).

Assembly



⚠ CAUTION!

Danger of fingers/hands being crushed, caught.
Danger of being injured by assembly parts falling down.

1. Clean shaft (11) thoroughly.
2. Attach coupler flange – shaft (10) with new spring (7) and push forward up to the stop.
3. All contact surfaces, including thread and connecting surface of the clamping bolts, must be clean and provided with an oil film.
 - > Mount shaft, hub and spring oiled, do not use any Molykote.
4. Pull coupler flange - shaft (10) together with the clamp (12) firmly to the bearing until the distance sleeve (13) fits closely to the bearing.
5. Tighten clamping screws (8) evenly and crosswise in several steps to the tightening torque MA * 145Nm as indicated.
6. Remove clamp (12).
7. Reinstall gear (1) with coupler flange (4) (see Chapter 11.3.1 + 11.3.2).

8. Carry out a test run.



Information!

Observe the drawing of construction unit of the drive and observe assembly instructions of the spring collets.

11.3.3 Replace gear of the discharge worm

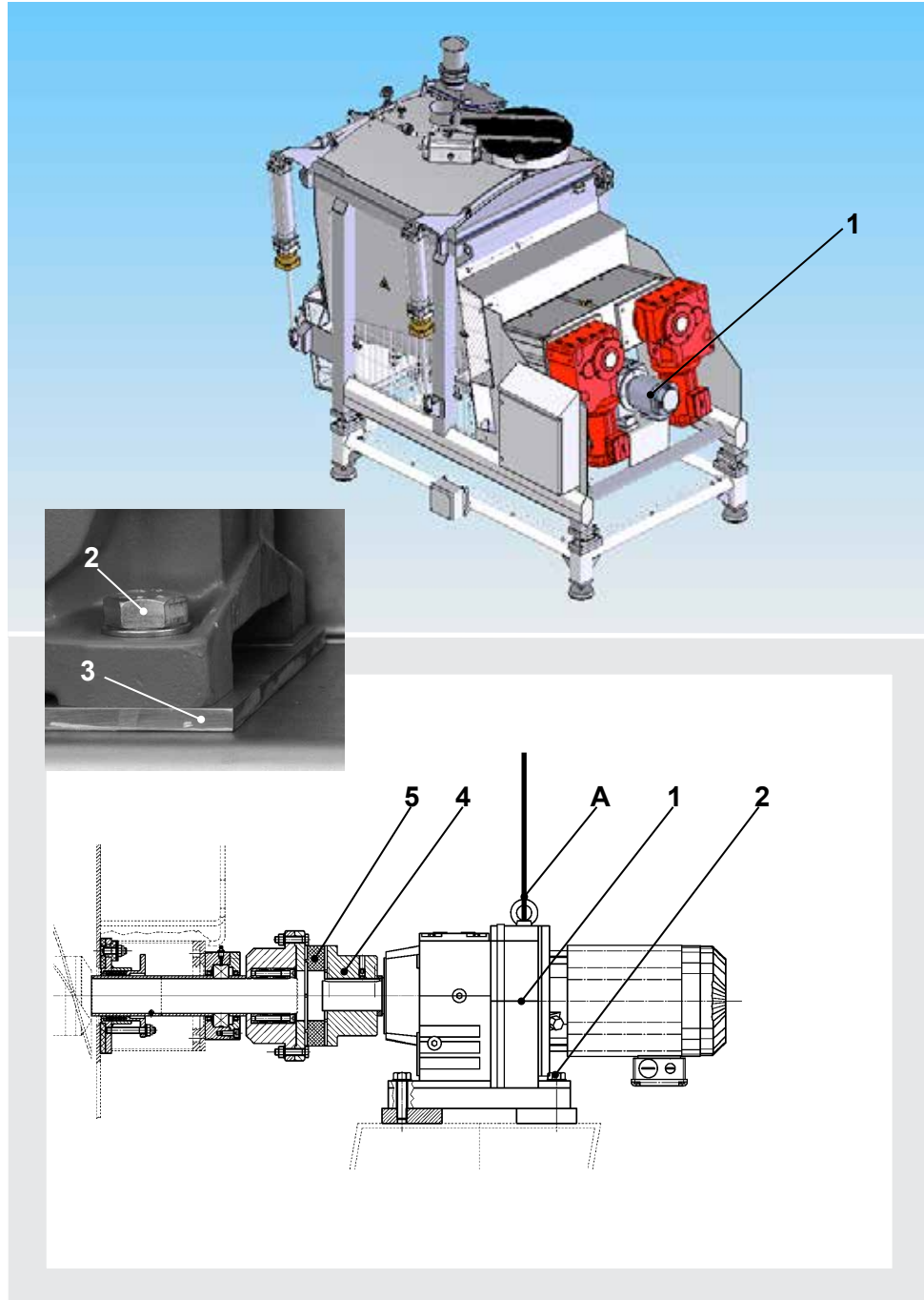

Drive drawing no.: 2-00101512

Pos.	Designation	Pos.	Designation
1	Gear	4	Coupler flange
2	Hexagonal bolt	5	Gear rim
3	Spacers	6	

Disassembly



⚠ CAUTION!

Danger of fingers/hands being crushed, caught.
Danger of being injured by assembly parts falling down.

1. Shut off power to the machine and secure against unauthorised restart.
2. Have the power supply cable-motor be disconnected by an authorised electrician.
3. Disassemble coupler protection.
4. Attach gear (1) with a carrying rope to the crane and protect against falling down.
 - > (Observe weight of the gear with coupler approx. 200 kg.)
5. Loosen all 4 hexagonal bolts (2) and unscrew them.
6. Pull gear (1) approx. 150 mm backwards.
7. Raise gear (1) with crane.
8. Check gear rim (5), replace if necessary.

Assembly



⚠ CAUTION!

Danger of fingers/hands being crushed, caught.
Danger of being injured by assembly parts falling down.

1. Put gear (1) onto the spacers (3) and push forwards up to the stop (observe the position of the coupling claws.)
2. Retighten gear (1).
3. Have the power supply cable-motor be connected by an authorised electrician.
4. Reinstall coupler protection.
5. Carry out a test run.



Information!

After each loosening of the spring or when reinstalling the chain wheel, a new spring must be used in any case.
All contact surfaces, including thread and connecting surface of the clamping bolts, must be clean and provided with an oil film.
Mount shaft, hub and spring after oiling them first.
Do not use any Molykote (type of grease.)

11.3.4 Replace gear of the discharge worm

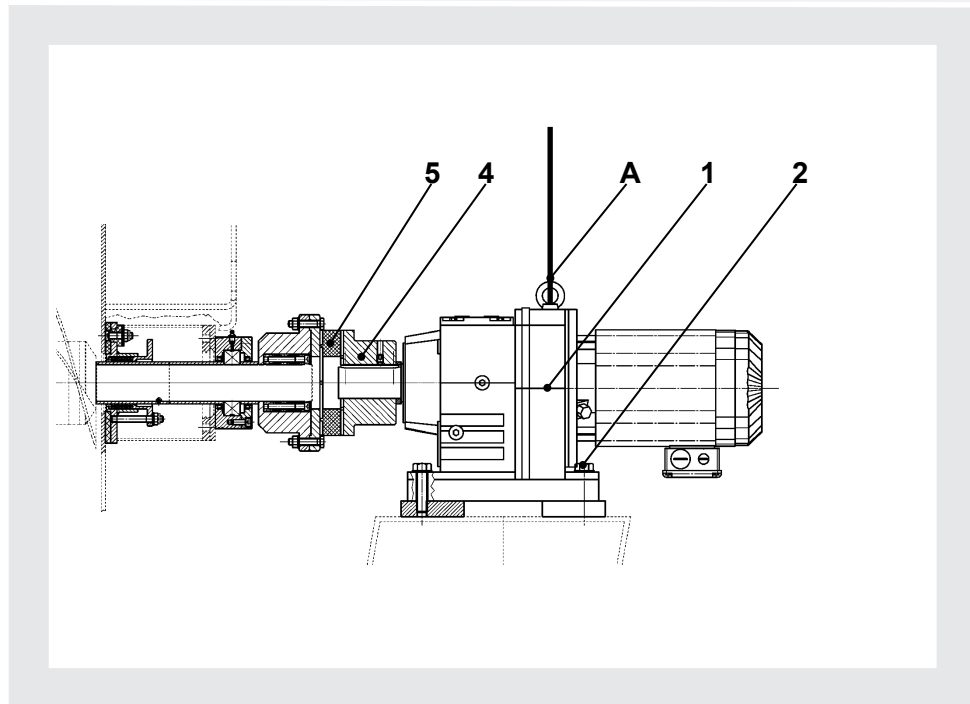
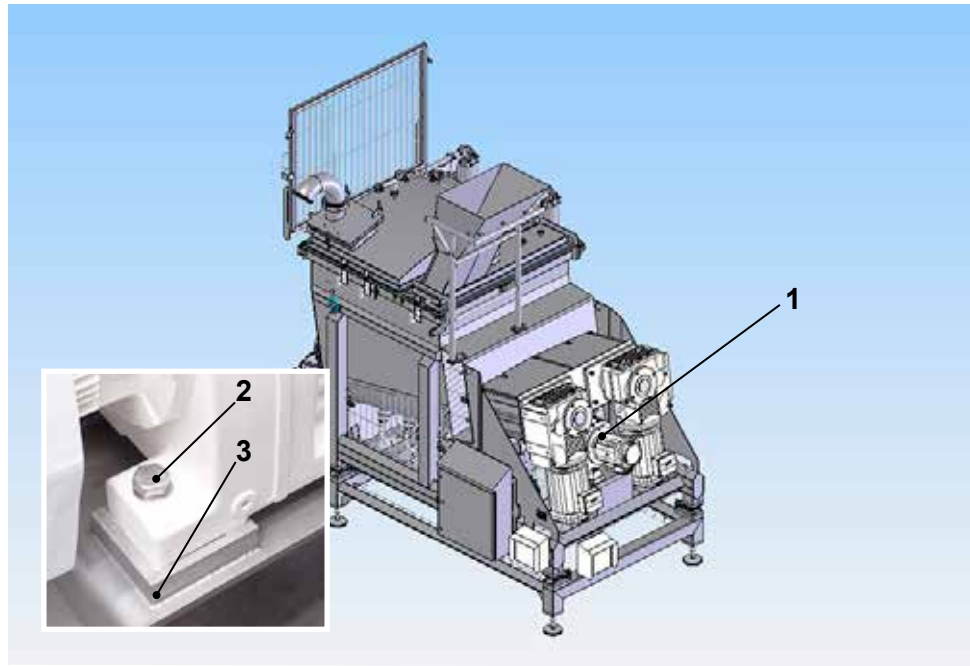

Drive drawing no.:2-00101512

Pos.	Designation	Pos.	Designation
1	Gear	4	Coupler flange
2	Hexagonal bolt	5	Gear rim
3	Spacers	6	

Disassembly



⚠ CAUTION!

Danger of fingers/hands being crushed, caught.
Danger of being injured by assembly parts falling down.

1. Shut off power to the machine and secure against unauthorised restart.
2. Have the power supply cable-motor be disconnected by an authorised electrician.
3. Disassemble coupler protection.
4. Attach gear (1) with a carrying rope to the crane and protect against falling down.
> (Observe weight of the gear with coupler approx. 200 kg.)
5. Loosen all 4 hexagonal bolts (2) and unscrew them.
6. Pull gear (1) approx. 150 mm backwards.
7. Raise gear (1) with crane.
8. Check gear rim (5), replace if necessary.

Assembly



⚠ CAUTION!

Danger of fingers/hands being crushed, caught.

Danger of being injured by assembly parts falling down.

1. Put gear (1) onto the spacers (3) and push forwards up to the stop (observe the position of the coupling claws.)
2. Retighten gear (1).
3. Have the power supply cable-motor be connected by an **authorised electrician**.
4. Reinstall coupler protection.
5. Carry out a test run.



Information!

After each loosening of the spring or when reinstalling the chain wheel, a new spring must be used in any case.

All contact surfaces, including thread and connecting surface of the clamping bolts, must be clean and provided with an oil film.

Mount shaft, hub and spring after oiling them first.

Do not use any Molykote (type of grease.)

11.3.5 Replace coupler and spring on the discharge worm



Drive drawing no.: 2-00101512

Pos.	Designation	Pos.	Designation
5	Gear rim	9	Head screw
6	Recording from the gear rim	10	Jack drills
7	Hexagonal bolt	11	Spring
8	Coupler flange of shaft	12	Shaft

Disassembly



▲ CAUTION!

Danger of fingers/hands being crushed, caught.
Danger of being injured by assembly parts falling down.

1. Shut off power to the machine and secure against unauthorised restart.

2. Remove drive gear (see Chapter 11.3.3).
3. Remove gear rim (5) from the recording from the gear rim (6).
4. Loosen all hexagonal bolt (7) and remove the recording from the gear rim (6).
5. Loosen all head screws (9) evenly and crosswise in several steps.
6. Screw in evenly head screws (9) into the jack drills (10).
 - > Spring (11) is slackened.
7. Pull spring (11) together with coupler flange shaft (8) from the shaft (12).
8. Only remove head screws (9) from the jack drills (10) when the spring (11) is dismantled completely.



Information!

After each loosening of the spring or when reinstalling the chain wheel, a new spring must be used in any case.
All contact surfaces, including thread and connecting surface of the clamping bolts, must be clean and provided with an oil film.
Mount shaft, hub and spring after oiling them first.
Do not use any Molykote (type of grease.)

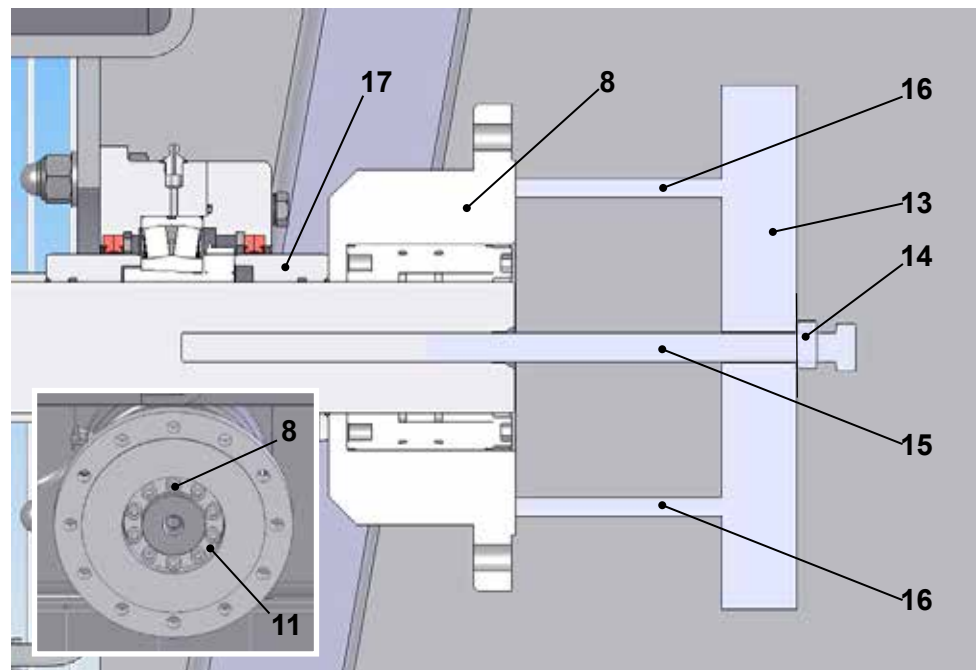

Drive drawing no.:2-00101512

Pos.	Designation	Pos.	Designation
13	Screw clamp	16	Spacer
14	Clamp nut	17	Bearing
15	Clamping bolt		



⚠ CAUTION!

Danger of fingers/hands being crushed, caught.
Danger of being injured by assembly parts falling down.

1. Clean thoroughly the take-up of the shaft (12).
2. Attach coupler flange shaft (8) with new spring (11) and push forward up to the stop.
3. Screw clamp (13) with the clamp nut (14) and the clamping bolt (15) into the shaft (12).

4. Attach spacers on the left and on the right (16) below the clamp (13) to the coupler flange of the worm shaft (8) and tighten clamp (13) with the clamping nut (14).
5. Screw in clamping bolt (14) until the coupler flange (8) is firmly in contact with the bearing (17).
6. Tighten clamping screws (9) evenly and crosswise in several steps to the tightening torque MA * 83Nm as indicated.
7. Remove clamp (13) completely.
8. Place the recording from the gear rim (6) on the coupling flange shaft (8) and tighten with the hexagon bolt (7).
9. Reinsert gear rim (5) into the coupler flange of the shaft (8).
10. Reinstall gear (1) with coupler flange (4) (see Chapter 11.3.3).
11. Carry out a test run.



Information!

Observe the drawing of construction unit of the drive.
Observe assembly instructions of the spring collets.

11.3.6 Check/replace bearing of outlet side

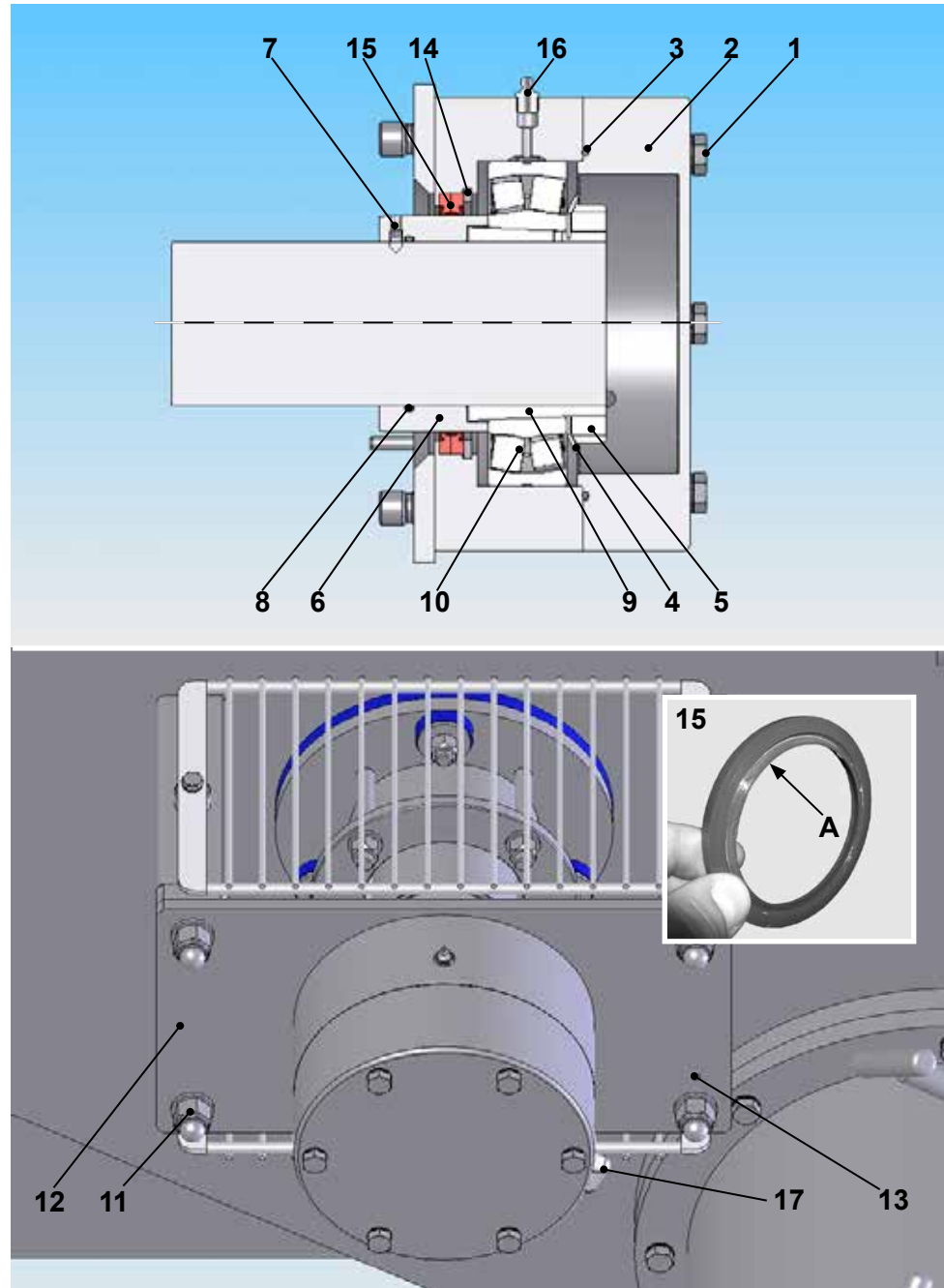

Shaft bearing 70 drawing no.: 2-00006444

Pos.	Designation	Pos.	Designation
1	Hexagonal bolt with tooth lock washer	10	Spherical roller bearing
2	Bearing lid	11	Hexagonal bolt with tooth lock washer
3	O-ring	12	Bearing plate
4	Safety plate	13	Dowel pin
5	Shaft channel nut	14	Locking ring
6	Bushing	15	Rotor seals
7	Grub screw	16	Lubricating line
8	O-ring	17	Overflow lubrication
9	Spring dowel	18	

Disassembly



DANGER!

Danger of falling down from the climbing aids

- ☞ Danger to life and limb. Severe injuries up to death.
- Use suitable climbing aids.



CAUTION!

Danger of the fingers/hands being crushed.

Danger of being injured by assembly parts falling down.

1. Shut off power to the machine and secure against unauthorised restart.
2. Loosen hexagonal bolts (1) at the lid (2) and unscrew them.
3. Remove bearing lid (2) together with the O-ring (3).
4. Loosen the safety plate (4).
5. Loosen shaft channel nuts (5) and unscrew them.
6. Mark installation position of the bushing (6) with a felt-tip pen.
7. Unscrew grub screw (7).
8. Force the spring dowel (9) with a pipe/mandrel so far to the rear until the spherical roller bearing (10) releases from the spring dowel.
9. Loosen hexagonal bolts (11) on the bearing plate (12) and unscrew them.
10. Bearing plate (12) is welded with the bearing flange, pull completely from the rear from the shaft and place it on an assembly table.
 - > Take care with the dowel pins (13).
11. Take out spherical roller bearing (10).
12. Take out locking ring (14).
13. Remove both rotor seals (15.1 +15.2).
14. Pull spring dowel (9) and bushing (6) from the shaft.
15. Check bushing (6) and O-ring (8) on inlet tracks, replace them if necessary.
16. Clean all assembly parts thoroughly.

Assembly



DANGER!

Danger of falling down from the climbing aids

- ☞ Danger to life and limb. Severe injuries up to death.
- Use suitable climbing aids.



CAUTION!

Danger of the fingers/hands being crushed.

Danger of being injured by assembly parts falling down.

1. Grease shafts with food-grade grease.
2. Push bushing (6) onto the shaft up to the marking and screw on with the grub screw (8) in the lowering.
 - > Take care with the position of the O-ring (8).
3. Insert rear rotor seal (15) with sealing lip (A) in direction to the bin.

4. Insert front rotor seal (15.1) with sealing lip (A) in direction to the bearing (9).
5. Reinstall locking ring (14).
6. Grease rotor seals and bushing (6) with food-grade grease.
7. Push bearing plate (12) carefully over the shaft onto the bushing,
 - > take care thereby that the sealing lip of the rear rotor seal is not crushed.
 - > Take care thereby of the position of the dowel pins (13) and the lubricating nipple (16).
8. Strike in both dowel pins (13) again.
9. Screw on bearing plate (12) with the 4 hexagonal bolts with the toothed washer (11) on the bin.
10. Insert spring dowel (9) together with the spherical roller bearing (10) via the shaft into the bearing flange (12) and press firmly to the rear.
11. Put on safety plate (4) and unscrew shaft channel nut (5) by hand.
12. Tighten shaft channel nut (5) with a hook spanner.
13. Grease spherical roller bearing (10) with food-grade grease.
14. Reinsert bearing lid (2).
 - > Take care with the position of the O-ring (3) and the grease overflow hose (17).
15. Screw on lid (2) with the 6 hexagonal bolts with the toothed washer (1).
16. Grease bearing completely.
17. Carry out a test run.

11.3.7 Check/replace bearing on the drive side of the mixing shaft and discharge worm

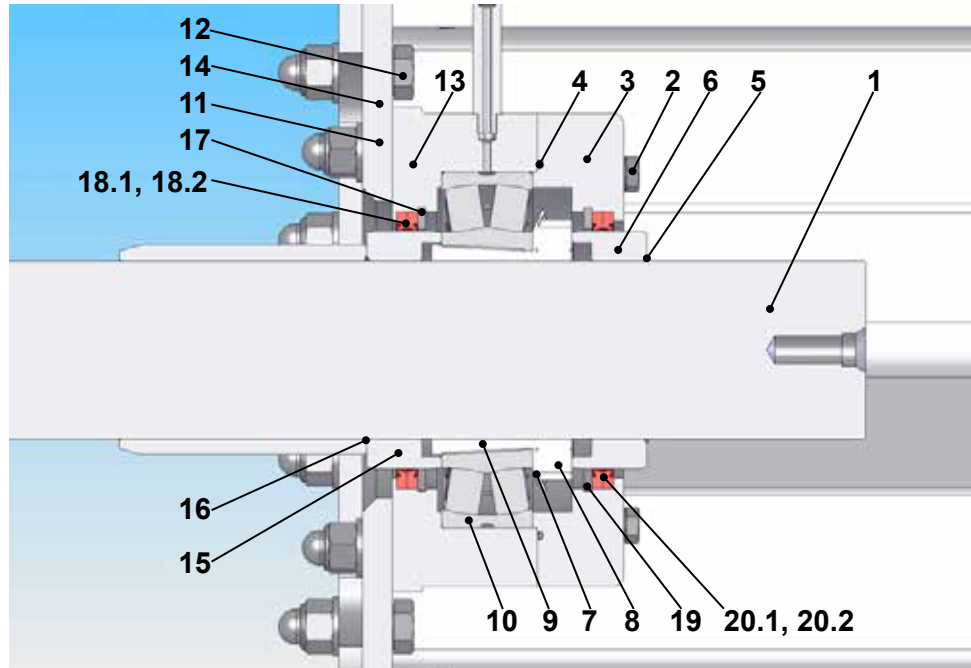

Shaft bearing 90 drawing no.: 2-00006087 - mixing shaft

Shaft bearing 70 drawing no.: 2-00006160 - discharge worm

Pos.	Designation	Pos.	Designation
1	Shaft	11	Control panel
2	Hexagonal bolt	12	Hexagonal bolt
3	Lid	13	Bearing flange
4	O-ring	14	Dowel pin
5	O-ring	15	Bushing
6	Bushing	16	O-ring
7	Safety plate	17	Locking ring
8	Shaft channel nut	18	Rotor seal
9	Spring dowel	19	Locking ring
10	Spherical roller bearing	20	Rotor seal

A replacement is necessary if:

- the bearing becomes very hot,
- the mixing shaft begins to touch the mixer tub.

Disassembly



▲ DANGER!

Danger of falling into the mixer tub.

- ☞ Danger to life and limb. Severe injuries up to death.
- Always keep off the mixer tub or the mixer rim.



▲ CAUTION!

Danger of the fingers/hands being crushed

- Fix mixing shaft in its installation position, e.g. protect against lowering by means of a rope and crane.

Danger of being injured by assembly parts falling down.

1. Shut off power to the machine and secure against unauthorised restart.
2. Disassemble drive gear and coupler (see Chapter 11.3..).
3. Fix shaft (1) in its installation position and protect with a rope against lowering.
4. Loosen hexagonal screws (2) at the lid (3) and unscrew them.
5. Remove lid (3) with O-ring (4) completely and place it on an assembly table.
6. Pull off O-ring (5) and bushing (6).
 - > Check bushing (6) for wear and damage, like e.g. deep tracks and renew if necessary.
7. Loosen the safety plate (7).
8. Loosen shaft channel nut (8) and turn back until the shaft channel nut (8) is flush with the spring dowel (9).
9. Force the spring dowel (9) with a mandrel or hammer from the shaft (1).
 - > Thus the spherical roller bearing (10) is detached from the spring dowel (9).
10. Unscrew shaft channel nut (8) and remove safety plate (7).
11. Protect control panel (11) with a rope against falling down.
12. Loosen fastening screws (12) and unscrew them.
13. Remove control panel (11) completely with the bearing flange (13) from the control panel on the mixer bin and place it on an assembly table.
 - > Take care with the dowel pins (14).
14. Remove bushing (15) and O-ring (16).
 - > Check bushing (15) for wear and damage, like e.g. deep tracks and renew if necessary.
15. Remove locking ring (17) in the bearing flange (13).
16. Remove both rotor seals (18.1 +18.2).
17. Remove locking ring (19) in the lid (3).
18. Remove both rotor seals (20.1 +20.2).
19. Clean all assembly parts of the bearing thoroughly.

Assembly

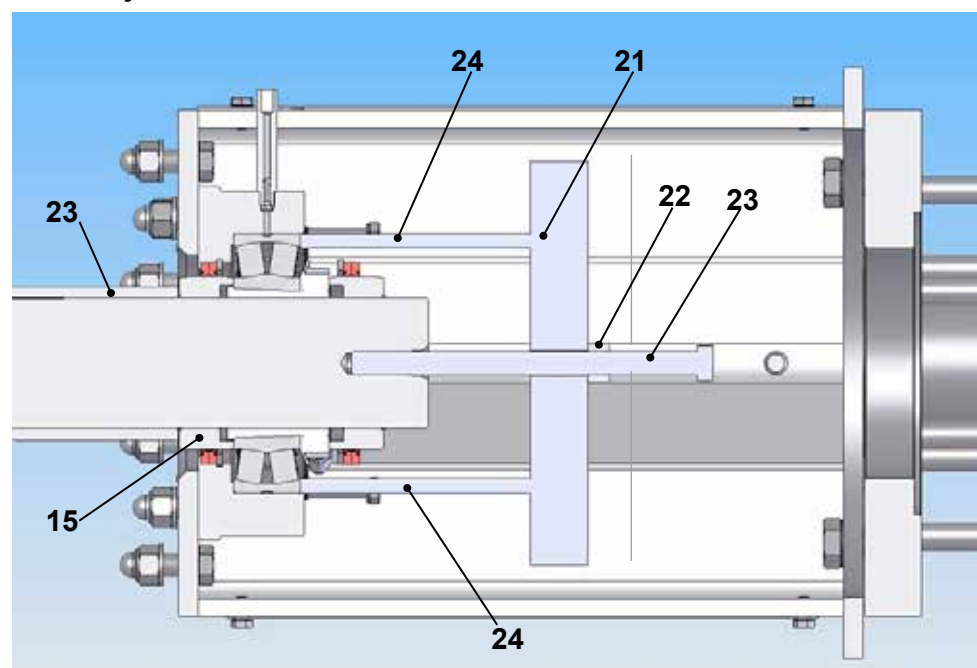



⚠ DANGER!

Danger of falling into the mixer tub.

- ☞ Danger to life and limb. Severe injuries up to death.
- Always keep off the mixer tub or the mixer rim.



⚠ CAUTION!

Danger of the fingers/hands being crushed.

Danger of being injured by assembly parts falling down.

1. Insert rear rotor seal (20.2) with sealing lip (A) outwards in the lid (3).
2. Insert front rotor seal (20.1) with sealing lip (A) inwards in the lid (3).
3. Reinstall sealing ring (19).
 - > Grease rotor seals with food-grade grease.
4. Insert rear rotor seal (18.2) with sealing lip (A) outwards in the bearing flange (13).
5. Insert front rotor seal (18.1) with sealing lip (A) inwards in the bearing flange (13).
6. Reinstall sealing ring (17).
 - > Grease rotor seals with food-grade grease.
7. Insert new O-ring (16)
8. Push bushing (16) forwards to the shaft up to the stop.
9. Put on control panel (11) completely with the bearing flange (13) over the motor shaft (1) and tighten it on the control panel of the mixer bin with the hexagonal screws (12).
 - > Observe thereby the position of the dowel pins.
10. Insert spring dowel (9) together with the spherical roller bearing (8) via the shaft into the bearing flange (13) and press firmly to the rear.
11. Put on safety plate (7) and unscrew shaft channel nut (9) by hand.
12. Screw clamp (21) with the clamp nut (22) and the clamping bolt (23) into the shaft (1).
13. Put spacers on the left and on the right (24) below the clamp (21) onto the bearing flange (13) and tighten clamp (21) with the clamping nut (22).
14. Screw in clamping nut (22) until the spacer sleeve (23) is firmly in contact with the bushing (14).
15. Tighten shaft channel nut (9) with a hook spanner.
16. Bend the safety plate (7).
17. Remove clamp (21) completely.
18. Grease spherical roller bearing (10) with food-grade grease.
19. Reinsert lid (3), take care with the position of the O-ring (4).
20. Screw on lid (3) with the 6 hexagonal screws (2).
21. Push bushing (6) forwards to the shaft up to the stop.
22. Put on new O-ring (5).
23. Reassemble gear and coupler (see Chapter 11.3..).

11.3.8 Stuffing box

Elements

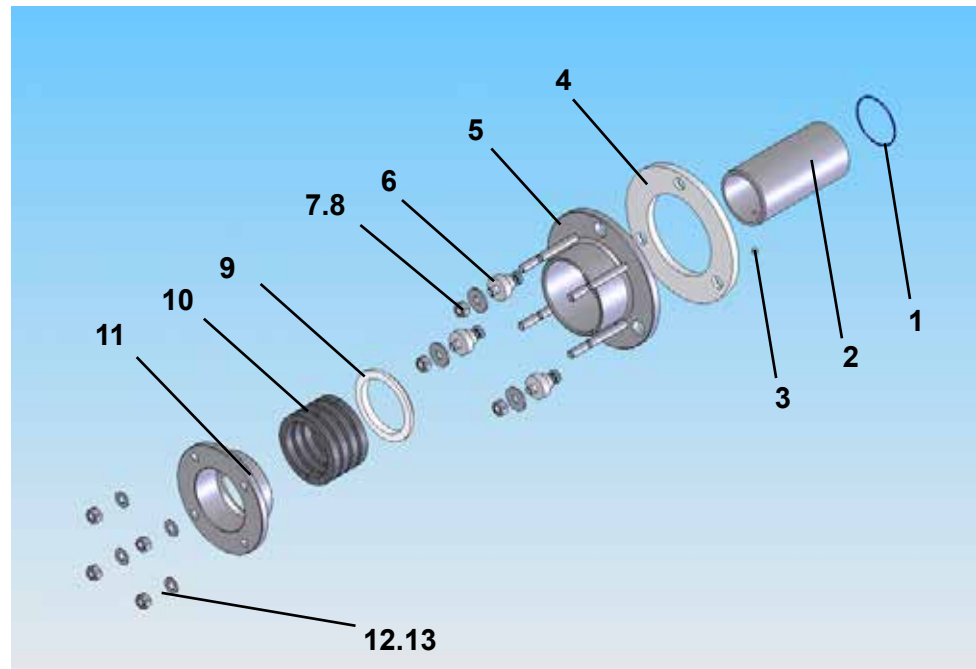

Pos.	Designation	Pos.	Designation
1	O-ring	8	Safety nut
2	Bushing	9	Chamber ring
3	Stud screw	10	Sealing material
4	Rubber ring	11	Thrust piece
5	Take-up	12	Washer
6	Rubber ring	13	Safety nut
7	Washer		

Replace packing rings of the stuffing box

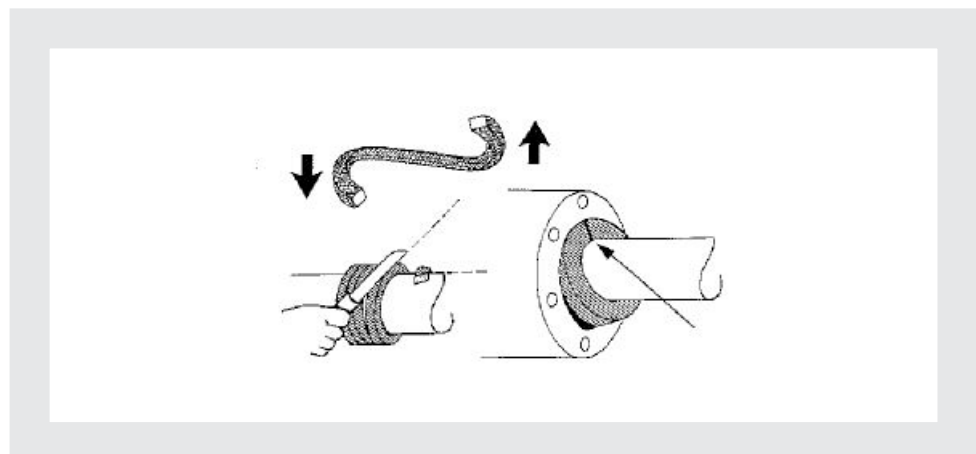
CAUTION!

Danger of being injured by parts falling down.

Prepare packing rings

For the sealing of the stuffing boxes cut-to-size packing rings are used.

The cutting to size of the packing rings out of metre goods must be performed precisely.

1. The sealing strand is wound over a shaft or a pipe with the same diameter as the bushing and then cut diagonally 45°.
 - > A diagonal cut increases the seal.
 - > Splicing of the cutting must be avoided by sticking the sealing material with adhesive tape.
 - > The cutting is then performed through the adhesive tape.

Removing the old seal material

1. Open outlet protection door and maintenance door.
2. Shut off power to the machine and secure against unauthorised restart.
3. Remove bearing completely on the outlet side.
4. Remove gear, coupler and bearing completely on the drive side (see Chapter 11.3...)
5. Unscrew safety nuts (13) and remove washers (12).
6. Pull thrust washer (11) backwards.
7. Screw extractor (Merkel company) into the sealing compound (10) and pull sealing compound out.
 - > Repeat process until all sealing tapes are removed.
8. Clean take-up, chamber ring (9) and bushing (2).
9. Check bushing (2) for wear and damage, like e.g. deep tracks and renew if necessary.

Installing the new seal material

1. Insert chamber ring (9) into the take-up (5).
2. Install sealing compound (10) successively into the take-up,
 - > hereby the cuttings of the single stripes must be twisted to one another by 180°.
3. Insert thrust washer (11) into the take-up (5).
4. Unscrew washers (12) and safety nut (13) and tighten evenly with approx. 5 Nm.
 - > An equal gap all around (S) must exist after having tighten the safety nuts (13).

Make a test run with product or water after completion of the installation.

1. Fill mixer tub over the mixing shafts.
2. Let the mixing shafts rotate approx. 15 minutes.
3. Check stuffing box:
 - > Sealing spot is leaky - tighten all safety nuts (13) evenly through one 1/2 rotation.
 - > Sealing spot is getting warm - loosen all safety nuts (13) evenly through one 1/2 rotation.

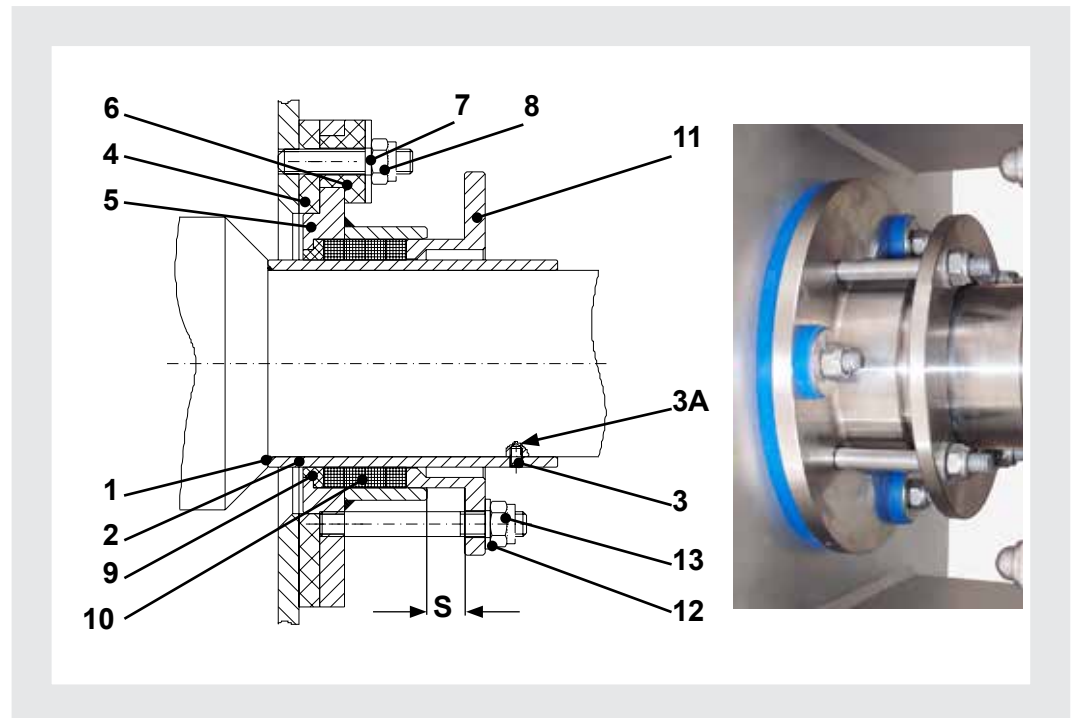

Replace stuffing box completely

Removal of the stuffing box

1. Open outlet protection door and maintenance door.
2. Shut off power to the machine and secure against unauthorised restart.
3. Remove bearing completely on the outlet side.
4. Remove gear, coupler and bearing completely on the drive side.
5. Unscrew safety nuts (13) and remove washers (12).
6. Pull thrust washer (11) backwards.
7. Screw extractor (Merkel company) into the sealing compound (10) and pull sealing compound out.
 - > Repeat process until all sealing tapes are removed.
8. Unscrew safety nuts (8), remove washers (7) and rubber buffer (6).
9. Pull off take-up with chamber ring (9).
10. Pull off rubber ring (4).
11. Unscrew stud screw (3) and pull off bushing (2).
12. Mark position of the lowering (3A) with a felt-tip pen.
13. Take off O-ring (1).
14. Clean all sealing surfaces.

Installation of the stuffing box

1. Push the O-ring (1) up to the shaft shoulder.
2. Push bushing (2), showing with the bevelled inner side to the front wall up to the shaft shoulder.
 - > Observe thereby the position of the lowering (3A) and the seat of the O-ring (1).
3. Press bushing (2) e.g. with a pipe against the shaft shoulder, the bushing
 - > must be in contact with the shaft shoulder.
4. Tighten stud screw (3).

5. Put on all following elements in the enumerated order:
 - > Rubber ring (4), with the bevelled boreholes showing to the front wall.
 - > Take-up with chamber ring (9).
 - > Insert sealing material (10).
 - > Thrust washer (11).
6. Install mixing shaft bearing (see chapter 11.3).
7. Put on rubber buffer (6) onto the threaded bolts.
8. Screw on washer (7) and safety nut (8) and tighten with approx. 5 Nm.
9. Insert thrust washer (10) into the take-up (5).
10. Unscrew washers (12) and safety nut (13) and tighten evenly with approx. 5 Nm.
 - > An equal gap all around (S) must exist after having tighten the safety nuts (13).
11. Remove gear, coupler and bearing completely on the drive side (See Chapter 11.3).
12. Carry out a test run.

11.3.9 Replace flange sleeve of discharge worm

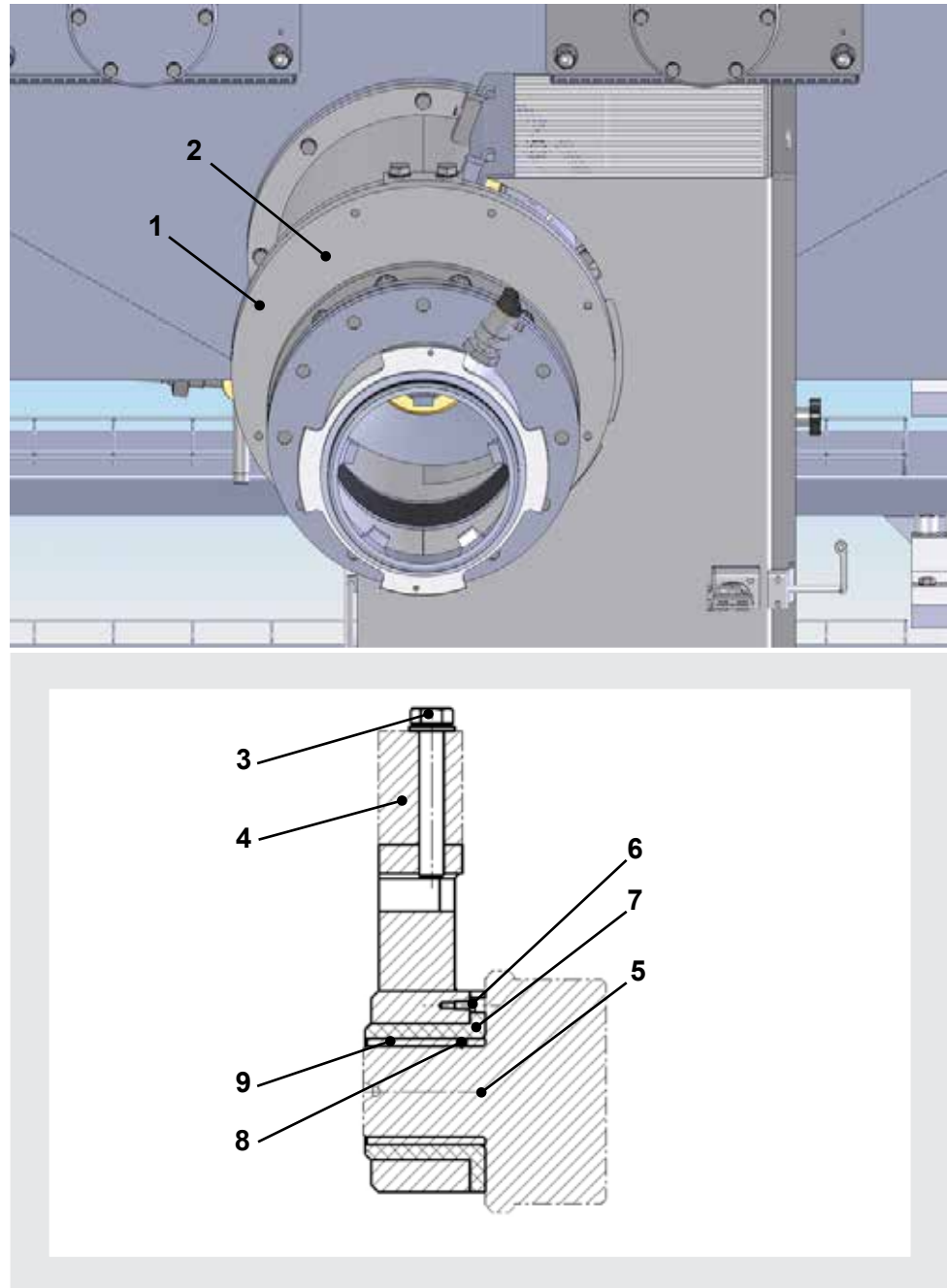

Slide bearing drawing no.: 2-00006140

Pos.	Designation	Pos.	Designation
1	Pipe section	6	Fillister head
2	Hexagonal bolt with tooth lock washer	7	Flange sleeve
3	Hexagonal bolt with tooth lock washer	8	Grub screw
4	Pedestal	9	Bushing
5	Shaft	10	Locking ring

A replacement is necessary if:

- the discharge worm begins to touch the worm trough.

Disassembly



⚠ CAUTION!

Danger of being injured by parts falling down.

1. Shut off power to the machine and secure against unauthorised restart.
2. Remove downstream connected machine (e. g. emulsifier).
3. Protect pipe section with carrying rope against falling down.
4. Loosen fastening bolts (2) at the pipe section (1) and unscrew them.
5. Remove pipe section (1).
6. Fix shaft into its installation position, e.g. by underlaying the shaft in the bin.
7. Loosen both hexagonal screws (3) and unscrew them.
8. Pull pedestal (4) completely from the shaft (5).
9. Loosen fillister head (6) and unscrew it.
10. Pull off flange sleeve (7).
11. Loosen grub screw (8) and unscrew it.
12. Withdraw bushing (9).
13. Clean thoroughly pedestal (4) and shaft journal.

Assembly



⚠ CAUTION!

Danger of being injured by parts falling down.

1. Push bushing (9) onto the shaft journal and tighten with the grub screw (8).
2. Press fit flange sleeve (7) into the pedestal and fix through the fillister head (6).
3. Grease bushing (4) with food-grade grease.
4. Push pedestal (4) completely to the shaft journal.
5. Screw on pedestal (4) with the both hexagonal screws (3).
6. Remove fixing aids.
7. Put on pipe section (1) on the connection flange and tighten again with the fastening bolts (2).
8. Carry out a test run.
9. Reinstall downstream connected machine.

11.3.10 Check/replace rubber seal of the mixer bin/man hole lid

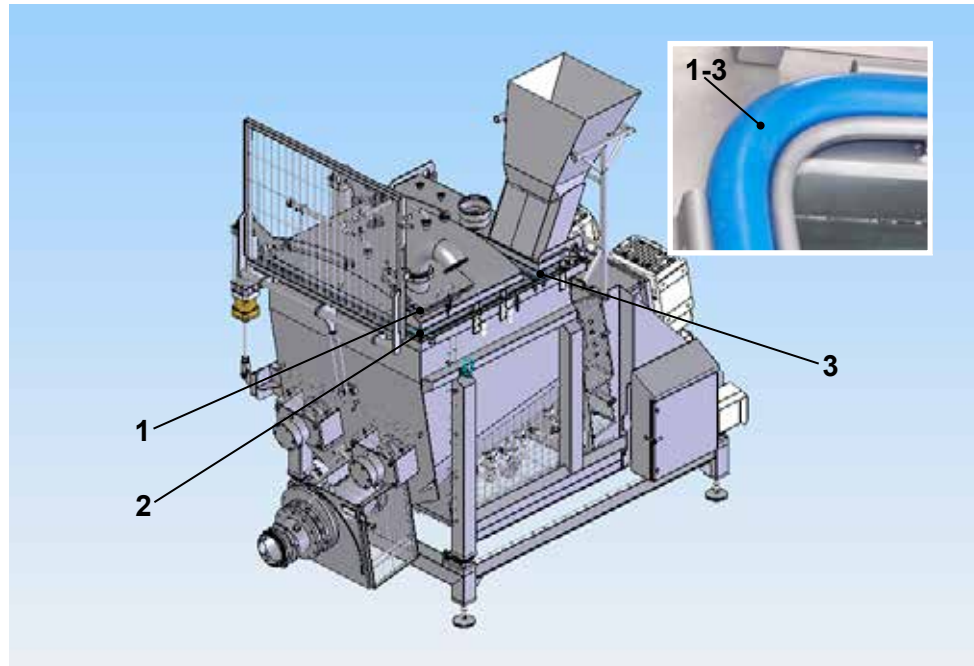

Item	Designation	Item	Designation
1	Rubber seal of man hole lid	3	Rubber seal of mixer lid
2	Rubber seal of mixer lid		



⚠ DANGER!

Danger of quickly falling/falling down from the cleaning platform or the climbing aid.

- Use a suitable climbing aid during maintenance and inspection work on the machine.

The mixer bin is equipped with a replaceable rubber seal. If the mixer does not draw vacuum any longer correctly, then the rubber seal must be replaced.



⚠ DANGER!

Danger of falling into the mixer tub.

- ☞ Danger to life and limb. Severe injuries up to death.
- Always keep off the mixer tub or the mixer rim.

1. Open bin lid.
2. Shut off power to the machine and secure against unauthorised restart.
3. Take rubber seal (1) out from the guide.
4. Clean completely mixer border.
5. Insert new rubber seal (1).
6. Close bin lid. Check flange sleeve.

11.3.11 Check/replace rubber seal of the cleaning flap

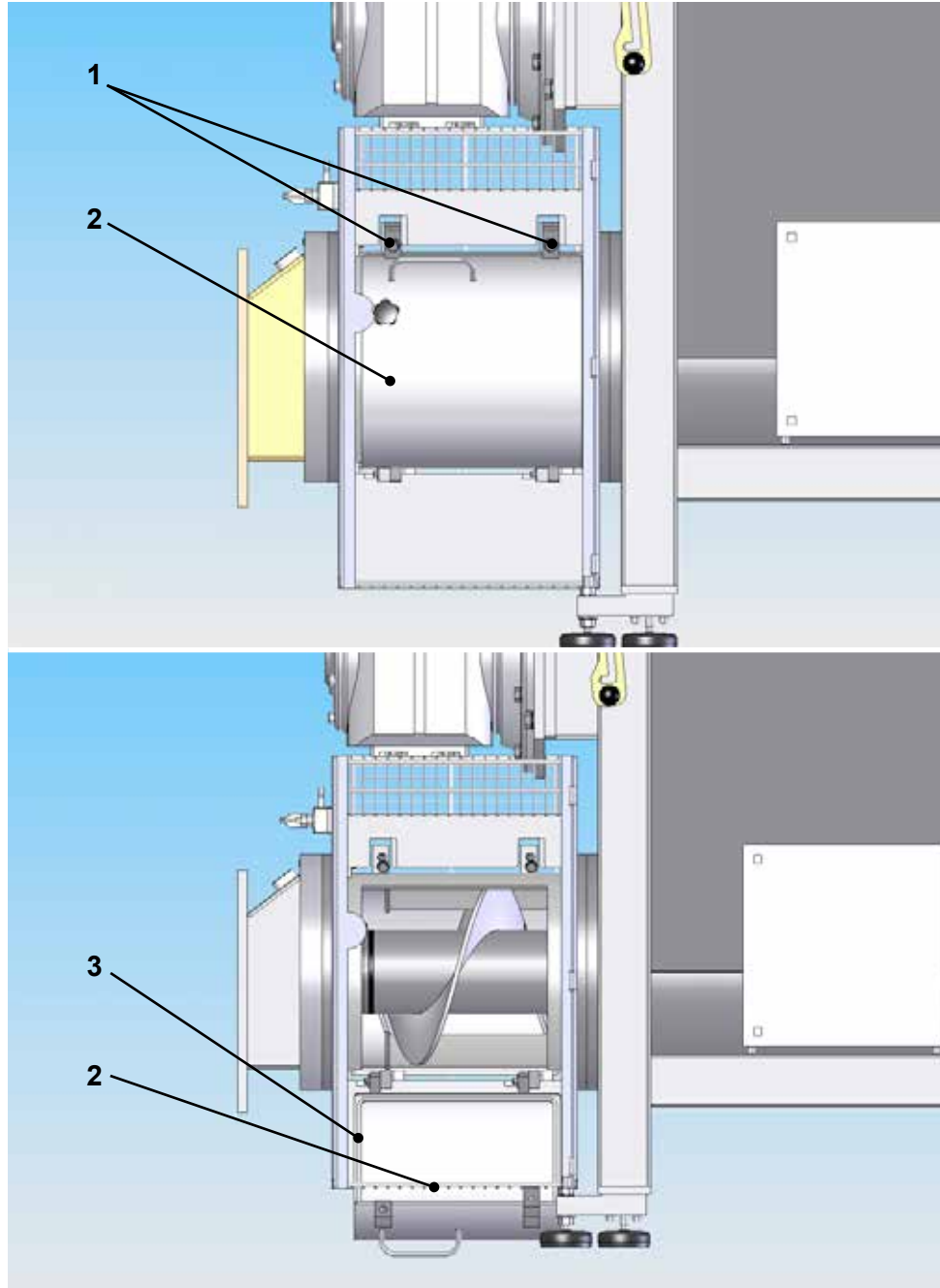

The cleaning flap is equipped with an exchangeable rubber seal. If product or water escapes outward during the production, then the rubber seal must be renewed.



⚠ CAUTION!

Danger of the fingers/hands being crushed.

Danger of being injured by assembly parts falling down.

1. Shut off power to the machine and secure against unauthorised restart.
2. Open outlet protection grid.
3. Loosen both fastening screws (1) at the cleaning flap (2) and unscrew them.
4. Swivel up cleaning flap (2).
5. Take out rubber seal (3).
6. Clean rubber seal take-up thoroughly.
7. Insert new rubber seal (3).

8. Close cleaning flap (2) again and tighten it with the both fastening bolts (1).
9. Close outlet protection grid again.

12 Shutting-down, storage and disposal

12.1 Safety information for the shutting-down, storage and disposal



DANGER!

Touching of live sections.

- Switch off voltage supply and protect against restarting.

Voltage-storage components installed (frequency converter.)

- Dangerous residual voltage.
- Pay attention to discharging time.
- Check clamping points on residual voltage.
- All works on the electrical equipments of the plant may be carried out in principle only by trained electricians.



DANGER!

Danger of falling into the mixer tub.

- Life-threatening cut injuries.
- Keep off the mixer tub or the mixer rim.



DANGER!

Machine parts which are put down incorrect or fitted improperly can fall down or topple.

Parts which are lying loosely on top of each other can slip or fall down.

Floating loads can fall down.

Too high stacked parts can topple.

- The transport may be carried out only by qualified persons under strict observation of the safety information.
- Lock the route of transport against unauthorised access.
- Transport the load close to the floor.
- Do not stay below floating loads.
- Do not stack the plant parts too high.
- Protect the parts against falling over.



DANGER!

Danger through assembly work which is not properly carried out.

- The assembly may be carried out only by qualified persons under strict observation of the safety information.
- Close the installation area of the machine against unauthorised access.
- Observe the safety sheets regarding the used process media (e.g. gear oils, hydraulic oils, roller bearing grease, detergents.)



CAUTION!

Risk of injury on open and accessible sharp-edged machine parts.

Protruding sharp edges can lead to cut injuries.

- Take care when handling machine parts.
- Wear personal protective-clothing such as a protective helmet, safety shoes and gloves.



⚠ CAUTION!

Danger of slipping and falling down from the ladders.

- Use suitable ladders when disassembling the machine parts.



Information!

Severe damage can be caused at the machine if other load lifting appliances will be used than the indicated ones.

- Only use approved and sufficiently dimensioned load lifting appliances.

12.2 Shutting down the machine

1. Discharge machine completely.
2. Clean machine.
 1. Shut off power to the machine and secure against unauthorised restart.
 2. Switch the current supply voltage-free.
 3. Disconnect the power supply cable.

12.3 Storing the machine

Short-term and medium-term storage (up to 2 years) is possible without special measures, under the ambient conditions specified in the technical data.

For longer-term storage, special measures to protect against corrosion are required.

12.4 Restarting the machine

Observe the procedure in Chapter 5.

12.5 Disassemble machine

1. Set the machine out of operation.
2. Disassemble machine from the upper assemblies downward.

12.6 Disposing of the machine

1. Dispose of all sections and consumables purely by sort and in accordance with the local valid guidelines and regulations.



Note

It is absolutely necessary to observe the regulations and laws governing the disposal of environmental pollutants.

Such materials include for example used oils, cooling agents, colours, plastics and chemicals.

In the case of doubt contact the manufacturer.

13 Spare parts

13.1 Spare parts list see document folder.



Information!

With bought-in parts it is not ensured that they are constructed and manufactured according to stress and safety standards.

- Use only original spare parts and wearing parts.

All machine parts not in proper working condition must be replaced without delay.

14 Appendix

14.1 Tightening torques of the screws

Pretensioning forces and tightening torques for screws with metric threads and head contact dimensions as in

DIN 912, 931, 934

Set screws, metric regular type screw thread, DIN 13, sheet 13

The following tables for the material categories A2 and A4 allow for a friction factor of $m_{ges} = 0.12$ for customary screws and nuts without lubrication.

Dimension	Property class 70 Standard A2-70, A4-70		Property class 80 Standard A4-80	
	Thread	Preload in N	Tightening torque in Nm	Preload in N
M5	3 000	3.5	4 750	4.7
M6	6 200	6	6 700	8.0
M8	12 200	16	13 700	22
M10	16 300	32	22 000	43
M12	24 200	56	32 000	75
M16	45 000	135	66 000	180
M20	71 000	280	95 000	370
M24	105 000	455	140 000	605
M30	191 000	1050	255 000	1 400

Screws of the property class A2-70 are used at KS as standard.



Information!

An additional lubrication of the threads changes the friction factor considerably and causes non-determinable tightening relations.

14.2 Tightening torques of the TAPER-LOCK springs

Bush	Tightening torque	Screws	Bush	Tightening torque	Screws
1008/1108	5.6	2	3020/3030	90	2
1210/1215	20	2	3525/3535	115	3
1610/1615	20	2	4030/4040	170	3
2012/2017	30	2	4535/4545	190	3
2517/2525	50	2	5040/5050	270	3

Installation

1. Clean all blank surfaces such as drill and outer cone of the TAPER-LOCK spring collet as well as the cone-shaped drill of the hub thoroughly and grease them. Insert then the bushing into the hub. All drills must be congruent.
2. Slightly oil thread and tip of the grub screw (when using cylinder head screws the bottom of the head) and screw in loosely.
3. Clean shaft and push the hub with the TAPER-LOCK spring collet on the shaft up to the required place.
4. The screws are tightened evenly by means of a hexagon spanner.
5. The TAPER-LOCK spring collet should be hammered with slight hammer strokes by means of a suitable sleeve or a log of a wood further into the conical drill. Afterwards the screws can be retightened slightly. This process should be repeated one or two times.
6. When using a spring key it must be first inserted into the groove. The spring key must be free. Without spring key the best balancing quality is reached by mounting the grooves of the shaft and the TL bushing offset by 180°.
7. After the drive has run a short time under load it should be checked whether the screws have not loosened.
8. The empty drills are filled with grease to prevent the penetration of foreign bodies.

Removal

1. All screws will be loosened and one or two screws will be unscrewed completely depending on the size of the TAPER-LOCK spring collet and the number of the jack drills. After having oiled the threads of the empty drills the screws are screwed slightly into these drills.
2. The screws should be tightened evenly until the TAPER-LOCK spring collet detaches from the hub and can be moved freely on the shaft.
3. The parts are lifted off from the hole plate.

Outline of the assembly description of the TAPER-LOCK spring collet.



Information!

The tightening torque of the TAPER-LOCK springs is entered with numeral punches on the shaft end.

14.3 Tightening torques of the springs

Springs RfN 7012

Dimension spring	Tightening torque (T_A) Nm	Dimension spring	Tightening torque (T_A) Nm
40x65	17	70x110	83
50x80	41	80x120	83
55x85	41	90x130	83
65x95	41	100x145	145

Springs RfN 7014

Dimension spring	Tightening torque (T_A) Nm	Dimension spring	Tightening torque (T_A) Nm
70x120	145	100x160	230
80x130	145	120x180	230
90x140	145	150x210	230

Springs (Clampex KTR)

Dimension spring	Tightening torque (T_A) Nm	Dimension spring	Tightening torque (T_A) Nm
19x35	4.9	70x110	88
65x95	41	120x165	145

Assembly

Clean contact surfaces of the spring as well as of the shaft and hub. Coat afterwards with thin oil. Insert spring into the seat of the hub and push it to onto the shaft. Tighten straining screws evenly crosswise. Thereby increase tightening torque gradually. Repeat process until the indicated tightening torque is available at all straining screws.



Information!

No oils or greases with molybdenum bisulfide or high-pressure additives, additives of teflon and silicone as well as lubricating grease paste may be used which considerably reduce the friction coefficient. With oil free assembly of the clamping cone deviating tables and calculation values result.

Disassembly

Unscrew all straining screws and screw in the pressure-test threading of the front conical ring. Tighten screws gradually and evenly with the half tightening torque T_A crosswise. Afterwards repeat the previous step with the full tightening torque. As soon as the front conical ring has loosened screw in the straining screws into the pressure-test threading of the intermediate ring to loosen the rear conical ring.



Information!

Make sure when using the clamping element again that the jack threads of the front conical ring and the intermediate ring are located in the initial original position. Thereby the slots of the front and rear ring as well as of the outer ring must align.

Outline of the assembly description of the CLAMPEX springs.



Information!

The tightening torque of the springs is entered with numeral punches on the shaft end.

15 Documents inclus

Additional documentation Mixer 1000 M.Nr.: 15459

KS designation	designation	customer
DOKU-SEW-001	Gear	SEW
DOKU-SEW-015	motor	SEW
DOKU-BUER-001	Angle-Seat Valve Typ 2000/2002	Bürkert

16 EC Declaration of Incorporation

